BASE PROSPECTUS

RELATING TO THE OFFERING OF STRUCTURED WARRANTS TO BE ISSUED BY



AmBank (M) Berhad

Registration No. 196901000166 (8515-D)
(Incorporated in Malaysia under the Companies Act 2016)

This Base Prospectus is published in connection with the offering of Structured Warrants (as hereinafter defined) to be issued from time to time (within the validity period of this Base Prospectus which expires on 28 September 2024) by AmBank (M) Berhad (“**Issuer**”). This Base Prospectus is intended to provide information on the Issuer and the Structured Warrants. The Structured Warrants are non-collateralised and comprise of:

- (i) American or European style cash-settled call or put warrants over a single equity;
- (ii) American or European style cash-settled call or put warrants over a basket of equities;
- (iii) American or European style physical-settled call warrants over a single equity;
- (iv) American or European style cash-settled call or put warrants over a single index;
- (v) American or European style cash-settled call or put warrants over a single exchange-traded fund;
- (vi) American or European style physical-settled call warrants over a single exchange-traded fund;
and/or
- (vii) Bull equity-linked structures,
(collectively “**Structured Warrants**”).

This Base Prospectus is published to provide information on the Issuer and the Structured Warrants. The specific terms relating to each series of Structured Warrants will be set out in the term sheets to be issued for the relevant Structured Warrants. The term sheets are supplemental to this Base Prospectus. This Base Prospectus and term sheet must be read together.

The Structured Warrants are to be listed and traded on the Structured Warrants Board of Bursa Malaysia Securities Berhad. No Structured Warrants will be offered based on this Base Prospectus after 12 months from the date of this Base Prospectus.

The date of this Base Prospectus is 29 September 2023.

YOU ARE ADVISED TO READ AND UNDERSTAND THE CONTENTS OF THIS BASE PROSPECTUS. IF IN DOUBT, PLEASE CONSULT A PROFESSIONAL ADVISER.

FOR INFORMATION CONCERNING RISK FACTORS WHICH YOU SHOULD CONSIDER, SEE RISK FACTORS COMMENCING ON PAGE 49.

RESPONSIBILITY STATEMENTS

OUR DIRECTORS HAVE SEEN AND APPROVED THIS BASE PROSPECTUS. OUR DIRECTORS COLLECTIVELY AND INDIVIDUALLY ACCEPT FULL RESPONSIBILITY FOR THE ACCURACY OF THE INFORMATION CONTAINED IN THIS BASE PROSPECTUS AND CONFIRM, HAVING MADE ALL REASONABLE ENQUIRIES, AND TO THE BEST OF THEIR KNOWLEDGE AND BELIEF, THERE IS NO FALSE OR MISLEADING STATEMENT OR OTHER FACTS THE OMISSION OF WHICH WOULD MAKE ANY STATEMENT IN THIS BASE PROSPECTUS FALSE OR MISLEADING.

WE, ACKNOWLEDGE THAT, BASED ON ALL AVAILABLE INFORMATION, AND TO THE BEST OF OUR KNOWLEDGE AND BELIEF, THIS BASE PROSPECTUS CONSTITUTES A FULL AND TRUE DISCLOSURE OF ALL MATERIAL FACTS CONCERNING THE OFFERING OF THE STRUCTURED WARRANTS (“OFFER”).

STATEMENTS OF RISK

YOU ARE WARNED THAT THE PRICE OR LEVEL (AS THE CASE MAY BE) OF THE UNDERLYING EQUITIES, UNDERLYING INDICES AND UNDERLYING EXCHANGE-TRADED FUNDS AND STRUCTURED WARRANTS MAY FALL IN VALUE AS RAPIDLY AS IT MAY RISE AND YOU MAY SUSTAIN A TOTAL LOSS OF YOUR INVESTMENT. YOU SHOULD THEREFORE MAKE SURE YOU UNDERSTAND THE TERMS AND CONDITIONS OF THE STRUCTURED WARRANTS OFFERED, THE RISK FACTORS INVOLVED, AND WHERE NECESSARY, SEEK PROFESSIONAL ADVICE BEFORE INVESTING IN THE STRUCTURED WARRANTS.

THE STRUCTURED WARRANTS CONSTITUTE GENERAL UNSECURED CONTRACTUAL OBLIGATIONS OF THE ISSUER AND OF NO OTHER PERSON. THEREFORE, IF YOU PURCHASE THE STRUCTURED WARRANTS, YOU ARE RELYING ON OUR CREDITWORTHINESS AND HAVE NO RECOURSE OR RIGHTS AGAINST THE UNDERLYING COMPANY WHICH HAS ISSUED THE UNDERLYING EQUITIES, OR THE UNDERLYING INDEX SPONSOR AND THE COMPANIES CONSTITUTING THE UNDERLYING INDEX OR THE UNDERLYING EXCHANGE-TRADED FUND AND THE ETF MANAGER.

STATEMENTS OF DISCLAIMER

THIS BASE PROSPECTUS HAS BEEN REGISTERED WITH THE SECURITIES COMMISSION MALAYSIA (“SC”). THE REGISTRATION OF THIS BASE PROSPECTUS SHOULD NOT BE TAKEN TO INDICATE THAT THE SC RECOMMENDS THE OFFER OR ASSUMES RESPONSIBILITY FOR THE CORRECTNESS OF ANY STATEMENT MADE, OPINION EXPRESSED OR REPORT CONTAINED IN THIS BASE PROSPECTUS. THE SC HAS NOT, IN ANY WAY, CONSIDERED THE MERITS OF THE STRUCTURED WARRANTS BEING OFFERED FOR INVESTMENT.

THE SC IS NOT LIABLE FOR ANY NON-DISCLOSURE ON OUR PART AND TAKES NO RESPONSIBILITY FOR THE CONTENTS OF THIS BASE PROSPECTUS, MAKES NO REPRESENTATION AS TO ITS ACCURACY OR COMPLETENESS AND EXPRESSLY DISCLAIMS ANY LIABILITY WHATSOEVER FOR ANY LOSS HOWSOEVER ARISING FROM OR IN RELIANCE UPON THE WHOLE OR ANY PART OF THE CONTENTS OF THIS BASE PROSPECTUS.

YOU SHOULD RELY ON YOUR OWN EVALUATION TO ASSESS THE MERITS AND RISKS OF THE INVESTMENT. IF YOU ARE IN ANY DOUBT AS TO THE ACTION TO BE TAKEN, YOU SHOULD CONSULT YOUR STOCKBROKERS, BANK MANAGERS, SOLICITORS, ACCOUNTANTS OR OTHER PROFESSIONAL ADVISERS IMMEDIATELY.

APPROVAL WILL BE OBTAINED FROM BURSA MALAYSIA SECURITIES BERHAD (“BURSA SECURITIES”) FOR THE LISTING OF AND QUOTATION OF THE STRUCTURED WARRANTS BEING OFFERED. ADMISSION OF THE STRUCTURED WARRANTS TO THE OFFICIAL LIST OF BURSA SECURITIES IS NOT TO BE TAKEN AS AN INDICATION OF OUR MERITS, THE MERITS OF THE OFFER, THE INVITATION, STRUCTURED WARRANTS, THE UNDERLYING EQUITIES, THE UNDERLYING EXCHANGE-TRADED FUNDS OR THE UNDERLYING INDICES.

A COPY OF THIS BASE PROSPECTUS HAS BEEN LODGED WITH THE REGISTRAR OF COMPANIES (“ROC”), WHO TAKES NO RESPONSIBILITY FOR ITS CONTENTS.

OTHER STATEMENTS

YOU SHOULD NOTE THAT YOU MAY SEEK RECOURSE UNDER SECTIONS 248, 249 AND 357 OF THE CAPITAL MARKETS AND SERVICES ACT 2007 (“**CMSA**”) FOR BREACHES OF SECURITIES LAW INCLUDING ANY STATEMENT IN THIS BASE PROSPECTUS THAT IS FALSE, MISLEADING OR FROM WHICH THERE IS A MATERIAL OMISSION OR FOR ANY MISLEADING OR DECEPTIVE ACT IN RELATION TO THIS BASE PROSPECTUS OR THE CONDUCT OF ANY OTHER PERSON IN RELATION TO THE ISSUER.

THE INFORMATION DISCLOSED IN THIS BASE PROSPECTUS IS IN ACCORDANCE WITH THE REQUIREMENTS UNDER THE CMSA FOR WHICH ANY PERSON SET OUT IN SECTION 236 OF THE CMSA IS RESPONSIBLE.

THIS BASE PROSPECTUS CAN ALSO BE VIEWED OR DOWNLOADED FROM BURSA SECURITIES’ WEBSITE AT WWW.BURSAMALAYSIA.COM.

PRIVACY NOTICE

PURSUANT TO SECTION 7 OF THE PERSONAL DATA PROTECTION ACT 2010, WE ARE REQUIRED TO ISSUE A PRIVACY NOTICE TO YOU WITH REGARD TO COLLECTION AND MANAGEMENT OF YOUR PERSONAL DATA. THE PRIVACY NOTICE (IN ENGLISH AND BAHASA MALAYSIA VERSIONS) IS ATTACHED AS “ANNEXURE II” FOR YOUR REFERENCE AND IS ALSO AVAILABLE AT OUR AMBANK STRUCTURED WARRANTS WEBSITE, WWW.AMBANKGROUP.COM/ENG/BUSINESS/AMWARRANTS.

[The rest of this page has been intentionally left blank]

DEFINITIONS

All references to “the Bank” or “the Issuer” or “AmBank” in this Base Prospectus are to AmBank (M) Berhad 196901000166 (8515-D), references to “our Group”, “AmBank Group” or “the Group” are to the AmBank and our subsidiaries and references to “we”, “us”, “our” and “ourselves” are to AmBank and, except where the context otherwise requires, the Group. Unless the context otherwise requires, references to “Management” are to our Directors and key management personnel as at the date of registration of this Base Prospectus with the SC, and statements as to our beliefs, expectations, estimates and opinions are those of our Management.

References to the “Government” are to the Government of Malaysia; references to “Ringgit”, “Ringgit Malaysia”, “RM” or “sen” are to the lawful currency of Malaysia; and references to a time of day are to Malaysian time, unless otherwise stated. Words importing the singular shall, where applicable, include the plural and vice versa and words importing the masculine gender shall, where applicable, include the feminine and neuter genders and vice versa. Reference to persons shall include companies and corporations. Any reference in this Base Prospectus or any Term Sheet to any enactment is a reference to that enactment as for the time being amended or re-enacted.

References to a “series” of the Structured Warrants are to each type of the Structured Warrants to be issued by us based on this Base Prospectus and a term sheet to be issued for each series of the Structured Warrants.

The following terms in this Base Prospectus bear the same meanings as set out below, unless the term is defined otherwise or the context otherwise requires:

Act	: Companies Act 2016
AmBank	: AmBank (M) Berhad Registration No. 196901000166 (8515-D)
AmBank Group	: AmBank and its subsidiaries
AmInvestment Bank	: AmInvestment Bank Berhad Registration No. 197501002220 (23742-V)
AMMB	: AMMB Holdings Berhad Registration No. 199101012723 (223035-V)
AMMB Group	: AMMB and its subsidiaries
BNM	: Bank Negara Malaysia
Board	: Board of Directors of AmBank
Bull ELS	: Bull equity-linked structures
Bursa Depository	: Bursa Malaysia Depository Sdn Bhd Registration No. 198701006854 (165570-W)
Bursa Securities	: Bursa Malaysia Securities Berhad Registration No. 200301033577 (635998-W)
Central Depositories Act	: Securities Industry (Central Depositories) Act 1991
Central Depository System	: The system for the central handling of securities established and operated by Bursa Depository
CMSA	: Capital Markets And Services Act 2007
Constitution	: The constitution (previously known as the memorandum and articles of association) of the Issuer

DEFINITIONS *(cont'd)*

Deed Poll	: The deed poll dated 22 September 2023 executed by us for the Structured Warrants, as amended, modified or supplemented from time to time in accordance to the provisions contained therein. The Term Sheet to be issued for each series of the Structured Warrants will form a new supplement to the Deed Poll. The Structured Warrants are governed by the detailed provisions of the Deed Poll. An extract of the principal terms of the Deed Poll is set out in Annexure I to this Base Prospectus
ETF(s)	: Exchange-traded fund(s)
ETF Manager	: The management company that establishes, operates and manages the ETF as well as issues units of ETF
ETF Structured Warrants	: in relation to the following Structured Warrants: <ul style="list-style-type: none"> (i) American and/or European style(s) cash-settled call warrants over a single ETF; (ii) American and/or European style(s) cash-settled put warrants over a single ETF; and (iii) American and/or European style(s) physical-settled call warrants over a single ETF
FPE	: Financial period ended
FSA	: Financial Services Act 2013
FX	: Foreign Exchange
FYE	: Financial year ended
Holder(s)	: The person or persons whose name(s) for the time being appear on the Record of Depositors for the Structured Warrants
Listing	: Listing of and quotation for the Structured Warrants on the Structured Warrants Board of Bursa Securities
Listing Requirements	: The Main Market Listing Requirements of Bursa Securities
LPD	: 1 September 2023, being the latest practicable date before the registration of this Base Prospectus
Market Day	: A day (other than Saturday, Sunday or public holiday) on which the relevant Securities Exchange(s) is/are open during the normal trading hours in the respective place where the relevant: <ul style="list-style-type: none"> (i) Underlying Equity(ies) is/(are) quoted and traded; (ii) Underlying ETF is quoted and traded; or (iii) Underlying Index is compiled and published, as the case may be, and the Structured Warrants are quoted and traded
Market Disruption Event	: As set out in Annexure I to this Base Prospectus
Market Maker	: A person who performs Market Making and is registered as a market maker under the Rules of Bursa Securities
Market Making	: The act of entering bid and offer prices in the automated trading system of Bursa Securities
Offer	: Our offering of the Structured Warrants

DEFINITIONS *(cont'd)*

Official List	: The list specifying all securities which have been admitted for listing on Bursa Securities and not removed
RAM Ratings	: RAM Rating Services Berhad Registration No. 200701005589 (763588-T)
Record of Depositors	: The record provided by Bursa Depository to AmBank or the Structured Warrants Registrar pursuant to the Rules of Bursa Depository
RM and sen	: Ringgit Malaysia and sen respectively
ROC	: Registrar of Companies Malaysia
Rules of Bursa Securities	: The rules of Bursa Securities
SC	: Securities Commission Malaysia
Securities Exchange(s)	: Such exchange(s) or quotation system(s) in Malaysia or securities exchange(s) outside Malaysia in which the Underlying Equity(ies) is/are quoted and/or traded, Underlying ETF(s) is/are quoted and/or traded or Underlying Index is compiled or published, as the case may be, or the Structured Warrants are quoted and/or traded as specified in the relevant Term Sheet
Settlement Disruption Event	: As set out in Annexure I to this Base Prospectus
Structured Warrant(s)	: The following are the non-collateralised structured warrants which we propose to issue: <ul style="list-style-type: none"> (i) American or European style cash-settled call or put warrants over a single equity; (ii) American or European style cash-settled call or put warrants over a basket of equities; (iii) American or European style physical-settled call warrants over a single equity; (iv) American or European style cash-settled call or put warrants over a single index; (v) American or European style cash-settled call or put warrants over a single ETF; (vi) American or European style physical-settled call warrants over a single ETF; and/or (vii) Bull ELS, <p>where the Underlying Equities and ETFs are listed on, and indices are based on Bursa Securities and/or Securities Exchanges outside Malaysia which are members of the World Federation of Exchanges or are approved by Bursa Securities</p>
Structured Warrants Registrar	: Tricor Investor & Issuing House Services Sdn Bhd (Registration No. 197101000970 (11324-H)), being the registrar of the Structured Warrants
Successor Underlying Index Sponsor	: In relation to particular Structured Warrants, the successor to the Underlying Index Sponsor
Take-Over Rules	: Rules on Take-Overs, Mergers and Compulsory Acquisitions

DEFINITIONS *(cont'd)*

- Term Sheet(s)** : The document(s) containing the specific terms and conditions and information on a specific series of Structured Warrants, to be issued by us from time to time and which shall be supplemental to and should be read in conjunction with the Deed Poll and this Base Prospectus
- Underlying Company(ies)** : In relation to a series of Structured Warrants, the company(ies) or corporation(s) that has(have) issued the Underlying Equity(ies)
- Underlying Equity(ies)** : In relation to a series of Structured Warrants, the equity or equities making up the basket of equities, as the case may be, which is(are) the subject of the series of Structured Warrants. Such equity(ies) is/are listed and quoted on Bursa Securities and/or securities exchange(s) outside Malaysia which is/are members of the World Federation of Exchanges or is/are approved by Bursa Securities, and as specified in the relevant Term Sheets
- Underlying ETF(s)** : In relation to a series of Structured Warrants, the ETF which is the subject of the series of Structured Warrants. Such ETF(s) is/are listed and quoted on Bursa Securities and/or securities exchange(s) outside Malaysia which is/are members of the World Federation of Exchanges or is/are approved by Bursa Securities, and as specified in the relevant Term Sheets
- Underlying ETF Assets** : In relation to an Underlying ETF, the assets of the Underlying ETF, as specified in the relevant Term Sheets
- Underlying Index(ices)** : In relation to a series of Structured Warrants, the index which is the subject of the series of Structured Warrants. Such index shall be based on Bursa Securities and/or Securities Exchange outside Malaysia which is approved by Bursa Securities and as specified in the relevant Term Sheet
- Underlying Index Sponsor** : In relation to a series of Structured Warrants, the index sponsor that compiles and publishes the Underlying Index, as specified in the relevant Term Sheets
- Underlying Instrument(s)** : In relation to a particular Structured Warrants, the Underlying Equity(ies), Underlying Index(ices) or Underlying ETF(s), as specified in the relevant Term Sheet
- USD** : United States Dollar
- VaR** : Value-at-Risk, which is a quantitative measure which applies to recent historic market conditions to estimate potential losses in market value, at a certain confidence level and over a specified holding period

[The rest of this page has been intentionally left blank]

GENERAL FEATURES AND GLOSSARY OF TERMS RELATING TO STRUCTURED WARRANTS

- American style** : An American style warrant may be exercised at any time from its issue date up to and including the expiry date
- Bull ELS** : Bull ELS gives the Holder an actual, contingent or prospective right to receive on settlement date:
- (i) a predetermined cash amount where the settlement price of the Underlying Equity(ies) is equal to or exceeds the Exercise Price; or
 - (ii) a specified number of Underlying Equity(ies) or a cash amount calculated by reference to the value of the Underlying Equity(ies) where the settlement price of the Underlying Equity(ies) is below the Exercise Price
- Call warrant** : Contract under which the Holder has the right but not the obligation to buy a specified number of the Underlying Instrument from the Issuer at Exercise Price on or by the expiry date (physical-settled), or to receive a cash payment when the call warrant has an intrinsic value on or by the expiry date (cash-settled)
- Cash Settlement Amount** : The amount of cash to be paid to the Holder on valid exercise of the Structured Warrants in accordance with Condition 2 of Parts 1 to 7 of Annexure I, as the case may be
- Cash Settlement Amount for Odd Lots** : The amount of cash to be paid to the Holder for odd lots of Underlying Equity or Underlying ETF on valid exercise of the Structured Warrants in accordance with Condition 2 of Part 3, Part 6 and Part 7 of Annexure I, as the case may be
- European style** : A European style warrant may only be exercised on the expiry date or in relation to physical-settled Structured Warrants, the ability to exercise that right on the expiry date up to 9.00 a.m. on the fifth (5th) Market Day following the expiry date
- Exercise Level** : The pre-specified level of the Underlying Index as determined by the Issuer at which the Holders may exercise the right under the series of Structured Warrants. The Exercise Level is subject to any adjustment as may be necessary in accordance with Condition 6 of Part 4 of Annexure I
- Exercise Price** : The pre-specified price of the Underlying Share or Underlying ETF as determined by the Issuer at which the Holders may exercise the right under the series of Structured Warrants. The Exercise Price is subject to any adjustment as may be necessary in accordance with Condition 6 of Part 1, Part 2, Part 3, Part 5, Part 6 and Part 7 of Annexure I
- Exercise Ratio** : The number of Structured Warrants to which one Underlying Equity, one basket of Underlying Equities, one Underlying ETF unit or one Underlying Index unit (as the case may be) relates as determined by the Issuer and as specified in the relevant Term Sheet. The Exercise Ratio is subject to any adjustment as may be necessary in accordance with the Condition 6 of Part 1 to Part 7 of Annexure I
- Exercise style** : Structured Warrants can be exercised, according to the terms of issue, in European or American Style
- In-the-money** : (i) A call warrant is in-the-money when the price or level of the Underlying Instrument is above the Exercise Price or Exercise Level of the call warrant, i.e. when the call warrant has an intrinsic value; and

GENERAL FEATURES AND GLOSSARY OF TERMS RELATING TO STRUCTURED WARRANTS
(cont'd)

(ii) A put warrant is in-the-money when the price or level of the Underlying Instrument is below the Exercise Price or Exercise Level of the put warrant, i.e. when the put warrant has an intrinsic value

Intrinsic value : (i) For a call warrant, the amount by which the price / level of the Underlying Instrument exceeds the Exercise Price / Exercise Level;
(ii) For a put warrant, the amount by which the price / level of the Underlying Instrument is below the Exercise Price / Exercise Level.

If a structured warrant has negative intrinsic value, it shall be deemed to have no intrinsic value

Out-of-the-money : (i) A call warrant is out-of-the-money when the price or level of the Underlying Instrument is below the Exercise Price or Exercise Level of the call warrant, i.e. when the call warrant does not have any intrinsic value; and
(ii) A put warrant is out-of-the-money when the price or level of the Underlying Instrument is above the Exercise Price or Exercise Level of the put warrant, i.e. when the put warrant does not have any intrinsic value

Physical Settlement Amount : The number of Underlying Equity or the Underlying ETF, as the case may be, to be delivered to the Holder on valid exercise of the Structured Warrants in accordance with Condition 2 of Part 3, Part 6 and Part 7 of Annexure I

Put warrant : Contract under which the Holder has the right but not the obligation to sell a specified number of the Underlying Instrument to the Issuer at Exercise Price on or by the expiry date (physical-settled), or to receive a cash payment when the put warrant has an intrinsic value on or by the expiry date (cash-settled)

[The rest of this page has been intentionally left blank]

FINANCIAL TERMS

Delta : The relationship between the expected change in the warrant price and the corresponding change in the Underlying Instrument price, as follows:-

$$\text{Delta} = \frac{\text{Change in the warrant price} \times \text{Exercise Ratio}}{\text{Change in the Underlying Instrument price/level}}$$

For example, for a call warrant with an Exercise Ratio of two (2), a delta of 50% implies that if the Underlying Instrument price changes by twenty (20) sen, then the call warrant price is expected to change by five (5) sen.

For example, for a put warrant with an Exercise Ratio of five (5), a delta of 50% implies that if the Underlying Instrument price changes by ten (10) sen, then the put warrant price is expected to change by one (1) sen.

Effective gearing : A measure of the theoretical change in the warrant price for a 1% change in the Underlying Instrument price. The formula for effective gearing is as follows:-

$$\text{Effective Gearing} = \text{Gearing} \times \text{Delta}$$

For illustrative purposes only, a gearing of five (5) and a delta of 60% would equate to an effective gearing multiple of three (3) times, which implies that every RM1.00 exposure in a warrant could equate to an effective exposure of RM3.00 in the Underlying Instrument

Gearing : A measure of the ratio of Underlying Instrument to which exposure is gained by purchasing one (1) warrant. The formula for gearing is as follows:-

$$\text{Gearing} = \frac{\text{Underlying Instrument price/level}}{(\text{warrant price} \times \text{Exercise Ratio})}$$

For illustrative purposes only, a gearing of five (5) implies that every ten (10) sen exposure in the warrant could equate to an exposure of fifty (50) sen in the Underlying Instrument (assuming the exercise ratio is one (1))

Implied volatility : The implied volatility of a warrant is the expected value of the volatility of the Underlying Instrument which, when input in a warrant pricing model (such as Black–Scholes) will return a theoretical value equal to the current market price of the warrant.

All things being equal, generally, the higher the expected volatility, the higher the Warrant price

Premium : The premium of the call warrant is calculated as follows:-

$$\frac{(\text{Call warrant price} \times \text{Exercise Ratio}) + \text{Exercise Price/Level} - \text{Underlying Instrument price/level}}{\text{Underlying Instrument price/level}} \times 100\%$$

The premium of the put warrant is calculated as follows:-

$$\frac{(\text{Put warrant price} \times \text{Exercise Ratio}) + \text{Underlying Instrument price/level} - \text{Exercise Price/Level}}{\text{Underlying Instrument price/level}} \times 100\%$$

Note:-

The financial terms above relate to warrants in general. For a 'basket' warrant, the market price referred to above would be computed based on the market prices of the equities underlying the 'basket' warrant. Where the Underlying Instrument is an index, the market price referred to above would be computed based on the level of the index underlying the warrant.

BEST AND WORST CASE SCENARIO OF INVESTMENT IN THE STRUCTURED WARRANTS

The following are illustrations of the best and worst case scenarios of investment in the Structured Warrants.

Best case scenario	Worst case scenario
In the case of Call warrants	
<p>The price/level of the Underlying Instrument rises substantially resulting in a significant increase in the price/level of the Call warrants.</p> <p>If you hold the Call warrants until its expiry date, the higher the closing price/level of Underlying Instrument exceeds the Exercise Price/Level, the higher the Cash Settlement Amount you will receive after considering any transaction cost.</p> <p>If you sell the Call warrants on Bursa Securities before its expiry date, with your selling price of the Call warrants higher than the purchase price, you will realise a profit in your investment after considering any transaction cost.</p>	<p>The price/level of the Underlying Instrument falls significantly resulting in a significant decrease in the price of the Call warrants.</p> <p>If you hold the Call warrants until its expiry date and the Call warrants expires out-of-money, the maximum loss will be your entire investment amount in the Call warrants plus any transaction cost.</p>
In the case of Put warrants:	
<p>The price/level of the Underlying Instrument falls substantially resulting in a significant increase in the price/level of the Put warrants.</p> <p>If you hold the Put warrants until its expiry date, the lower the closing price/level of Underlying Instrument compared to the Exercise Price/Level, the higher the Cash Settlement Amount you will receive after considering any transaction cost.</p> <p>If you sell the Put warrants on Bursa Securities before its expiry date, with your selling price of the Put warrants higher than the purchase price, you will realise a profit in your investment after considering any transaction cost.</p>	<p>The price/level of the Underlying Instrument rises significantly resulting in a significant decrease in the price of the Put warrants.</p> <p>If you hold the Put warrants until its expiry date and the Put warrants expires out-of-money, the maximum loss will be your entire investment amount in the Put warrants plus any transaction cost.</p>
In the case of Bull ELS:	
<p>On the expiry date, if the settlement price of the Underlying Equity of the Bull ELS is equal to or exceeds the Exercise Price, you will receive a Cash Settlement Amount after considering any transaction cost. If the Cash Settlement Amount is higher than your purchase price, you will realise a profit in your investment.</p>	<p>On the expiry date, if the settlement price of the Underlying Equity of the Bull ELS is less than the Exercise Price, you will receive a Physical Settlement Amount. If the market value of the Underlying Equity is at zero, you will lose the entire investment amount in Bull ELS plus any transaction cost.</p>

[The rest of this page has been intentionally left blank]

TABLE OF CONTENTS

1.	CORPORATE DIRECTORY	1
2.	INTRODUCTION	4
3.	PROSPECTUS SUMMARY	5
3.1	The Offer	5
3.2	Information on AmBank.....	5
3.3	Purpose of the Offer	7
3.4	Risk Factors	7
3.5	Risk Management	14
4.	INFORMATION ON AMBANK	15
4.1	Background and Business	15
4.2	Share Capital.....	20
4.3	Rating Profile.....	20
4.4	Our Board.....	21
4.5	Our Key Management Team.....	21
4.6	Management	21
4.7	Our Group	22
4.8	Financial Highlights	26
4.9	Risk Management	33
4.10	Audit and Examination Committee	43
4.11	Hedging Strategy for Structured Warrants	43
4.12	Previous Experience with Structured Warrants	44
5.	PARTICULARS OF THE OFFER.....	45
5.1	The Offer	45
5.2	Market Making.....	45
5.3	Further Issue	47
5.4	Purposes of the Offer	48
6.	RISK FACTORS.....	49
6.1	Risks Relating to Us.....	49
6.2	Risks Relating to Our Structured Warrants	53
6.3	Risks Relating to the Underlying Companies, Underlying Equities, Underlying ETFs and Underlying Indices.....	57
6.4	Other Risks.....	63
7.	APPROVALS AND CONDITIONS	67
8.	DECLARATION BY THE SOLICITORS.....	68
9.	ADDITIONAL INFORMATION	69
9.1	Material Litigation	69
9.2	Material Contracts	69
9.3	Consents	69
9.4	Documents for Inspection	69
9.5	General.....	69
9.6	Responsibility Statement.....	69

[The rest of this page has been intentionally left blank]

TABLE OF CONTENTS *(cont'd)*

ANNEXURE I	PRINCIPAL TERMS OF THE DEED POLL	70
	Definitions.....	70
	Part 1 Conditions of the Cash-Settled Single Equity Call or Put Warrants.....	78
	Part 2 Conditions of the Cash-Settled Basket Equities Call or Put Warrants.....	97
	Part 3 Conditions of the Physical-Settled Single Equity Call Warrants	120
	Part 4 Conditions of the Cash-Settled Single Index Call or Put Warrants.....	138
	Part 5 Conditions of the Cash-Settled Single Exchange-Traded Fund Call or Put Warrants.	151
	Part 6 Conditions of the Physical-Settled Exchange-Traded Fund Call Warrants	167
	Part 7 Conditions of the Bull Equity-Linked Structure.....	183
ANNEXURE II	PDPA PRIVACY NOTICE	199

[The rest of this page has been intentionally left blank]

1. CORPORATE DIRECTORY**DIRECTORS**

Name	Designation	Address	Nationality / Profession
Voon Seng Chuan	Chairman/ Independent Non-Executive Director	11 Lengkok Zaaba 2 Taman Tun Dr Ismail 60000 Kuala Lumpur Malaysia	Malaysian/ Company Director
Soo Kim Wai	Non-Independent Non-Executive Director	A-07-03 Serai Bukit Bandaraya 98, Jalan Medang Serai Bukit Bandaraya Bangsar 59100 Kuala Lumpur Malaysia	Malaysian/ Company Director
Dato' Sri Abdul Hamid bin Abdul Hafiz	Independent Non-Executive Director	32 Jalan 14/30 46100 Petaling Jaya Selangor Malaysia	Malaysian/ Company Director
Dr Veerinderjeet Singh a/l Tejwant Singh	Independent Non-Executive Director	Unit 3-7-6 The Residence Condominium Jalan Wan Kadir 5 Taman Tun Dr Ismail 60000 Kuala Lumpur Malaysia	Malaysian/ Company Director
U Chen Hock	Independent Non-Executive Director	Mont Kiara 10 Unit BA-18-02 Jalan Kiara 1 50480 Kuala Lumpur Malaysia	Malaysian/ Company Director
Ng Chih Kaye	Independent Non-Executive Director	53 Jalan Hujan Bubuk Taman Overseas Union 58200 Kuala Lumpur Malaysia	Malaysian/ Company Director
Foong Pik Yee	Independent Non-Executive Director	E-07-03, Vivaldi Kiara 1 Jalan 19/70A Desa Sri Hartamas 50480 Kuala Lumpur Malaysia	Malaysian/ Company Director

AUDIT AND EXAMINATION COMMITTEE

Our Audit and Examination Committee comprises the following members:

Name	Designation	Directorship
Dr Veerinderjeet Singh a/l Tejwant Singh	Chairman	Independent Non-Executive Director
U Chen Hock	Member	Independent Non-Executive Director
Foong Pik Yee	Member	Independent Non-Executive Director

1. CORPORATE DIRECTORY *(cont'd)*

- ISSUER** : AmBank (M) Berhad
Registration No. 196901000166 (8515-D)
22nd Floor, Bangunan AmBank Group
No. 55 Jalan Raja Chulan
50200 Kuala Lumpur, Malaysia
Telephone No: 03-2036 2633
Website: www.ambankgroup.com
<https://www.ambankgroup.com/eng/Business/AmWarrants>
Email: ED-AS@ambankgroup.com
- COMPANY SECRETARY** : Koid Phaik Gunn
Company Secretary
SSM PC No. 202008003140
MAICSA 7007433
No. 15 Jalan Birai U8/68
Bukit Jelutong, Seksyen U8
40150 Shah Alam
Selangor, Malaysia
- REGISTERED / HEAD OFFICE** : 22nd Floor, Bangunan AmBank Group
No. 55 Jalan Raja Chulan
50200 Kuala Lumpur, Malaysia
Telephone No: 03-2036 2633
Website: www.ambankgroup.com
- AUDITORS** : Ernst & Young PLT
202006000003 (LLP0022760-LCA) & AF 0039
Level 23A, Menara Milenium
Jalan Damanlela
Pusat Bandar Damansara
50490 Kuala Lumpur, Malaysia
Telephone No: 03-7495 8000
Website: www.ey.com
- SOLICITORS** : Zaid Ibrahim & Co. (in association with KPMG Law)
Level 19, Menara Milenium
Jalan Damanlela
Pusat Bandar Damansara
50490 Kuala Lumpur
Telephone no: 03-2087 9999
Website: www.zicolaw.com
- STRUCTURED WARRANTS REGISTRAR** : Tricor Investor & Issuing House Services Sdn Bhd
Registration No. 197101000970 (11324-H)
Unit 32-01, Level 32, Tower A,
Vertical Business Suite, Avenue 3, Bangsar South
No. 8, Jalan Kerinchi
59200 Kuala Lumpur, Malaysia
Telephone No: 03-2783 9299
Website: www.tricorglobal.com
- RATING AGENCY** : RAM Rating Services Berhad
Registration No. 200701005589 (763588-T)
Level 8, Mercu 2, KL Eco City
No. 3, Jalan Bangsar, 59200
Kuala Lumpur, Malaysia
Telephone No: 03-3385 2488
Website: www.ram.com.my

1. CORPORATE DIRECTORY *(cont'd)*

LISTING

: We will seek the approval of Bursa Securities for the listing of and quotation for the Structured Warrants on the Structured Warrants Board of Bursa Securities

[The rest of this page has been intentionally left blank]

2. INTRODUCTION

This Base Prospectus is dated 29 September 2023 and is valid until 28 September 2024.

We have registered a copy of this Base Prospectus with the SC. We have also lodged a copy of this Base Prospectus with the ROC. Neither the SC nor the ROC takes any responsibility for the contents of this Base Prospectus.

The Structured Warrants will be listed and traded on the Structured Warrants Board of Bursa Securities, subject to the approval of Bursa Securities.

Under Section 14(1) of the Central Depositories Act, the Structured Warrants are prescribed securities which are required to be deposited into the Central Depository System. Consequently, any dealings in these Structured Warrants will be carried out in accordance with the Central Depositories Act and the Rules of Bursa Depository.

The completion of the Offer and Listing for each series of the Structured Warrants depends on the following:

- (i) for all Structured Warrants other than the Bull ELS, there must be at least a hundred (100) Holders holding not less than one (1) board lot of the relevant series of Structured Warrants each, or at least fifty (50) Holders holding not less than one (1) board lot each provided that these Holders subscribes for a minimum of RM100,000 of the relevant series of Structured Warrants each according to the Listing Requirements. 1 board lot comprises 100 Structured Warrants or such other number of Structured Warrants as permitted by the SC and/or Bursa Securities; and
- (ii) each issue of the relevant series of the Structured Warrants must have a total face amount of not less than RM5 million according to Listing Requirements.

The above mentioned requirement in (i) does not apply to an Issuer that provides liquidity for the Structured Warrants via Market Making or an issuer of Bull ELS in accordance with the Listing Requirements.

You should rely only on the information contained in this Base Prospectus and the relevant Term Sheets in respect of the Offer. We have not authorised any person to give you any information or to make any representation that is not contained in this Base Prospectus and the relevant Term Sheets.

We may update or amend this Base Prospectus from time to time by way of successor documents. You should ask us if any supplement to this Base Prospectus has been issued. Any supplement to this Base Prospectus will be available on Bursa Securities' website, www.bursamalaysia.com or on our website, www.ambankgroup.com/eng/Business/AmWarrants and will also be available for inspection at our registered office or the office of the Structured Warrants Registrar during its office hours for a period of twelve (12) months from the date of this Base Prospectus.

The distribution of this Base Prospectus and the sale of the Structured Warrants are subject to Malaysian law. We take no responsibility for the distribution of this Base Prospectus and the sale of the Structured Warrants outside Malaysia. This Base Prospectus may not be used as an invitation to purchase or an offer to sell any Structured Warrants in any jurisdiction or to any persons, if it would render such invitation or offer unlawful.

You should rely on your own evaluation to assess the merits and risks of the Offer and an investment in the Structured Warrants. In considering the investment, if you are in any doubt as to your course of action, you should consult your stockbrokers, bank managers, solicitors, accountants or other professional advisers immediately.

[The rest of this page has been intentionally left blank]

3. PROSPECTUS SUMMARY

This Prospectus Summary only highlights the key information from other parts of this Base Prospectus. It does not contain all the information that may be important to you. You should read and understand the contents of this whole Base Prospectus and the relevant Term Sheet prior to deciding on whether to invest in the Structured Warrants.

3.1 The Offer

We propose to issue the following non-collateralised structured warrants:-

- (i) American or European style cash-settled call or put warrants over a single equity;
- (ii) American or European style cash-settled call or put warrants over a basket of equities;
- (iii) American or European style physical-settled call warrants over a single equity;
- (iv) American or European style cash-settled call or put warrants over a single index;
- (v) American or European style cash-settled call or put warrants over a single ETF;
- (vi) American or European style physical-settled call warrants over a single ETF; and/or
- (vii) Bull ELS,

where the Underlying Equities and ETFs are listed on, and indices are based on Bursa Securities and/or Securities Exchanges outside Malaysia which are members of the World Federation of Exchanges or are approved by Bursa Securities.

The Structured Warrants will be offered from time to time by way of placement to selected investors or by way of Market Making.

We will issue the Structured Warrants from time to time through this Base Prospectus supported by a Term Sheet to be issued before we issue each series of the Structured Warrants.

Further information on the Offer and the Structured Warrants are set out in Section 5 of this Base Prospectus respectively.

3.2 Information on AmBank

3.2.1 Background and business

AmBank is a public limited company incorporated in Malaysia on 25 March 1969 under the Act with the name of Malaysia Borneo Finance Corporation (M) Berhad and assumed its present name of AmBank (M) Berhad on 1 June 2005 upon the merger of AMMB Group's banking and finance company businesses.

AmBank is a licensed commercial bank under the FSA and is regulated by BNM. It offers commercial banking services which include loans and financing, deposit services, credit cards, remittance and foreign exchange services which focused on retail, corporate and institutional customers.

Further information on AmBank and its business and operations are set out in Section 4.1 of this Base Prospectus.

[The rest of this page has been intentionally left blank]

3. PROSPECTUS SUMMARY (cont'd)**3.2.2 Financial Highlights**

Our Group's audited financial information for the FYE 31 March 2021, FYE 31 March 2022, FYE 31 March 2023 and the unaudited consolidated financial statements for the three (3) months FPE 30 June 2023 are set out below:-

	←-----FYE 31 March-----→ (RM'000)			Unaudited 3-months FPE
	2021	2022	2023	30 June 2023 (RM'000)
Consolidated statements of profit or loss				
Interest income	4,008,681	3,940,247	5,059,927	1,510,341
Interest expense	(2,061,934)	(1,784,418)	(2,713,306)	(959,119)
Net interest income	1,946,747	2,155,829	2,346,621	551,222
Other operating income	717,252	540,756	673,920	210,348
Share in results of an associate	(1,319)	(708)	2,798	(7)
Net income	2,662,680	2,695,877	3,023,339	761,563
Other operating expenses	(1,282,516)	(1,300,780)	(1,428,435)	(329,986)
Operating profit	1,380,164	1,395,097	1,594,904	431,577
Net impairment allowance, provision write back and other recoveries	(645,883)	(261,651)	(173,535)	(151,943)
Apportionment of settlement cost	(2,535,000)	-	-	-
(Loss)/profit before taxation	(1,800,719)	1,133,446	1,421,369	279,634
Taxation	(162,574)	(119,824)	(327,632)	(60,327)
(Loss)/profit for the financial year/period	(1,963,293)	1,013,622	1,093,737	219,307
Attributable to:				
Equity holder of the Bank	(1,963,285)	1,013,622	1,093,738	219,307
Non-controlling interests	(8)	-	(1)	-
(Loss)/profit for the financial year	(1,963,293)	1,013,622	1,093,737	219,307
Basic/diluted (loss)/earnings per share (sen)	(234.50)	107.57	115.14	23.09
Dividends per share (sen) ⁽¹⁾	-	-	-	17.30
Financial ratio				
Return on equity (%) ⁽²⁾	(20.80)	10.76	10.28	7.83
Dividend payout ratio (%) ⁽³⁾	-	-	-	15.02

	←-----As at 31 March-----→ (RM'000)			Unaudited as at
	2021	2022	2023	30 June 2023 (RM'000)
Consolidated statements of Financial Position				
Total Assets	111,568,168	119,103,880	136,855,462	134,703,487
Total Liabilities	102,806,220	109,021,858	125,655,766	123,372,921
Total Liabilities and Equity	111,568,168	119,103,880	136,855,462	134,703,487
Net Assets Per Share (RM)	9.70	10.61	11.79	11.93

3. PROSPECTUS SUMMARY *(cont'd)*

Notes:-

1. *Dividend (ordinary) per share in respect of the financial year/period.*
2. *“Return on Equity” means profit/(loss) for the financial year/period attributable to the equity holder of the Bank as a percentage of the average of beginning and year/period end shareholder’s funds.*
3. *Dividend payout ratio refers to the ratio of the total amount of dividends paid in the financial period ended 30 June 2023 in respect of the profit for the financial year ended 31 March 2023 of the Group.*

Further information on financial highlights are set out in Section 4.8 of this Base Prospectus.

3.3 Purpose of the Offer

The Offer is in line with our objective to actively participate and contribute to the development, promotion and growth of Structured Warrants in the Malaysian capital market. Save for Bull ELS, Structured Warrants offer some degree of leverage or gearing, where a small percentage change in the price / level of the Underlying Instruments may result in larger percentage change in the price of the Structured Warrants. The Offer also enables us to earn revenue in which the proceeds from the Offer will be utilised for our general working capital requirements, hedging costs and to defray cost and expenses for the Offer.

Further information on the purpose of the Offer is set out in Section 5.4 of this Base Prospectus.

3.4 Risk Factors

Investing in the Structured Warrants involves a certain degree of risk. As a potential applicant for an investment in the Structured Warrants, you should rely on your own evaluation and consult your professional independent adviser before investing in the Structured Warrants. Please read the following summary of risk factors together with the risk factors set out in Section 6 of this Base Prospectus and the risk factors listed below in addition to the other information contained throughout this Base Prospectus as well as the relevant Term Sheet in respect of an Offer before applying for and investing in the Structured Warrants:-

Risks relating to us, as the Issuer:-

- Credit risk

If you subscribe for or purchase our Structured Warrants, you are therefore relying solely upon our creditworthiness as the issuer and of no other person. You must evaluate our credit risk in relation to our ability to fulfil our obligations as the issuer of our Structured Warrants. Any downgrade in the rating accorded to our outstanding debt securities by our rating agency could result in a reduction in the price of the Structured Warrants.

- Trading by our Group

We or any other member of within our Group may trade the Underlying Equities, the Underlying ETFs or any other securities and financial products relating to any of the Underlying Companies, Underlying ETFs or Underlying Indices. These trading activities may affect (positively or negatively) the following:

- (i) the price at which the Underlying Equities or the Underlying ETFs (as the case may be) are traded on Bursa Securities or other Securities Exchange outside Malaysia;
- (ii) the price / level at which any other securities and financial products relating to any of the Underlying Companies, Underlying ETFs or Underlying Indices are traded on Bursa Securities or other Securities Exchanges outside Malaysia; or
- (iii) the price at which the Structured Warrants are traded on Bursa Securities.

- Exercise of discretion by us

We may exercise our discretion to make adjustments to the Structured Warrants (for example, to the Exercise Price and Exercise Ratio of the Structured Warrants) in circumstances contemplated under the terms of the Deed Poll which could affect the price of the Structured

3. PROSPECTUS SUMMARY *(cont'd)*

Warrants for instance in the event of bonus issue, rights issue, subdivision or consolidation of the Underlying Equities (such as stock split or consolidation of stocks) or Underlying ETFs and capital repayment by the Underlying Companies or management companies of the Underlying ETFs.

- No investigation or review performed on the Underlying Companies, the Underlying ETFs, the Underlying Index Sponsor or the companies constituting the Underlying Index

We have not carried out any investigation or review on the business operations and prospects of the Underlying Companies. We have also not performed any investigation or review on the Underlying ETFs, the Underlying Index Sponsor or the companies constituting the Underlying Index. Accordingly, your investment decision should be based upon your own independent assessment and appraisal of the Structured Warrants, the Underlying Companies, the Underlying ETFs, the Underlying Index Sponsor and/or the companies constituting the Underlying Index. Investing in the Structured Warrants without adequate assessment and appraisals may lead to unanticipated losses that could have been avoided otherwise.

- Potential conflict of interests

We or the companies in our Group, may from time to time offer customized debt and capital financing solutions to our client, deal in the Underlying Instrument for our own account, or issue other derivative products in respect of the Underlying Instrument. Such activities and transactions may have resulted in a movement of the price / level of the Underlying Instruments. Any negative movement of the price / level of the Underlying Instruments may consequentially have an adverse effect on the price of our Structured Warrants. Any potential conflict of interests is mitigated by our establishment of internal controls (such as Management of Conflict of Interest Policy and Guidelines) and our compliance with strict policies, regulations and guidelines issued (from time to time) by the SC, Bursa Securities and BNM with regards to managing any potential conflict of interest situation.

- Early termination due to liquidation, dissolution or winding up of the Issuer

In the event of liquidation, dissolution, winding-up or appointment of a receiver and/or administrator in respect of the whole or substantial part of our undertakings, properties or assets, the outstanding and unexercised Structured Warrants will be deemed exercised early and, subject to the terms of the Deed Poll, settled in cash an amount as determined by us. Hence, there is a risk that the Structured Warrants may be cancelled before the relevant expiry date of such Structured Warrants and cause you to suffer a loss or achieve a reduced profit.

- Take-over or scheme of arrangement or any other form of reorganization undertaken by the Issuer

In the event of a take-over, a scheme of arrangement or any other form of reorganization undertaken by or involving us or any other events having similar effects on the rights of the Holders, we may in our discretion make any adjustments to the rights attaching to the relevant Structured Warrants in a commercially reasonable manner. This may have a negative impact on the price of the relevant Structured Warrants.

- Merger, amalgamation or reconstruction involving the Issuer

In the event of a merger, amalgamation or reconstruction involving us, the corporation, trust or other body into which we are merged, amalgamated or reconstructed shall assume all our liabilities and obligations in respect of the Structured Warrants so that the rights of Holders shall continue to exist and be enforceable.

- Legal and regulatory risks

Our Group is subjected to potential legal actions and regulatory actions against its banking and non-banking entities arising from or in connection with their business activities and operations. Any of these material legal actions and/or regulatory actions could have adverse financial and/or reputational effects on AmBank Group and/or any of the specific entities within AmBank Group. Changes in legislations and regulations could impose more stringent requirements or impose restrictions on our activities/business. This could have an adverse effect on the competitiveness and profitability of AmBank Group, which would in turn have an adverse effect on our business, financial condition, operations, and consequently our capability to meet the obligation in relation

3. PROSPECTUS SUMMARY (cont'd)

to the Structured Warrants.

- Reputational risk

Reputational risk is the risk that a company will lose current and future business because its character or quality has been called into question and/or incur substantial financial penalties arising from the failure to comply with relevant laws and regulations. Any damage to the reputation of our Group may have an adverse effect on the financial performance and/or future prospects of our Group, consequentially affecting the price of our Structured Warrants.

- Losses due to climate change

Climate change related impacts include risks such as physical risks from changing climatic conditions which could disrupt our Group's operations or the operations of customers or third parties on which our Group relies. Failure to effectively manage these risks could adversely affect the Issuer's business, prospects, reputation, financial performance or financial condition, which could in turn affect the price of the Structured Warrants.

Risks relating to our Structured Warrants:-

- General investment risks

It is recommended that you should have experience in warrant or option transactions and should reach an investment decision only after carefully considering, with your adviser, the suitability of the Structured Warrants for you. The Structured Warrants are considered to be suitable only for those who fully understand the risks involved and are prepared to sustain a complete loss of the purchase price paid for the Structured Warrants.

- Factors affecting the price of our Structured Warrants

The traded price of our Structured Warrants on Bursa Securities is dependent upon, amongst others, the liquidity, Exercise Price or Exercise Level, the time remaining to expiration of the Structured Warrants, the volatility and liquidity of the Underlying Equities and the Underlying ETFs, the performance of the Underlying Indices, and the demand and supply of the Structured Warrants in the secondary market. There is no assurance that the market price of the Structured Warrants will, upon and after Listing, be equal to or exceed the price paid by investors.

- Holders have no shareholder rights

Cash-settled Structured Warrants do not give Holders any rights to the Underlying Equities, the Underlying ETFs or the equities of the companies constituting the Underlying Index. The Holders of Bull ELS and physical-settled Structured Warrants will have no rights as shareholder of the Underlying Companies or the Underlying ETFs prior to the exercise of the Structured Warrants until the Underlying Equities or the Underlying ETFs have been delivered to exercising Holders.

- Holders shall bear the risk of fluctuations in the price / level of the Underlying Instruments

The leverage provided by investing in the Structured Warrants means that a small percentage of change in the price or level of the Underlying Instruments may result in a larger percentage of change in the price of the Structured Warrants. As such, the return on your investment will be negatively affected and you may risk losing your entire investment if the price or level of the Underlying Instruments does not move in the anticipated direction.

- Time decay

A Structured Warrant's price consists of intrinsic value and time value. Investors should be aware that Structured Warrant's time value decreases (decay) over time and will be closer to zero as it approaches its expiry date. As such, if you hold a Structured Warrant for a period of time, this decay may offset some or all of the gain caused by a movement in the Underlying Instruments.

- Limited life of the Structured Warrants

The Structured Warrants have expiry dates and therefore, a limited life. After the expiry date, our Structured Warrants will cease to be traded and can no longer be exercised, hence they will cease to have any value. It is possible that our Structured Warrants will expire without your expectations being realised.

3. PROSPECTUS SUMMARY *(cont'd)*

- Risk of “European style” Structured Warrants

European style Structured Warrants are only exercisable on its expiry date. Accordingly, if the Cash Settlement Amount on a European style Structured Warrant is zero or below zero on the expiry date, you will lose the entire value of your investment.

- Structured Warrants as hedging instruments for investor

There are risks and complexities involved should you purchase the Structured Warrants for the purpose of hedging against the market risk associated with investing in or otherwise having the exposure to any Underlying Instruments. For example, there is no assurance that the price of the Structured Warrants will correlate with the movements of the Underlying Equities, Underlying ETFs or Underlying Indices. Hence, the Structured Warrants may not eliminate all market risk relating to the Underlying Instruments or a portfolio of investment consisting of the Underlying Instruments.

- Adjustments to the terms of the Structured Warrants under certain circumstances

Certain events relating to the Underlying Equities, Underlying ETFs or Underlying Indices (such as bonus issue, rights issue, subdivision or consolidation and capital repayment), permit us to make adjustments or amendments to amongst others, the Exercise Price or Exercise Level and/or Exercise Ratio of the Structured Warrants, as contemplated under the terms of the Deed Poll. Events in respect of which no adjustment is made to the Exercise Price or Exercise Level and/or Exercise Ratio may cause the Structured Warrants to be out-of-the-money and/or affect the trading price of the Structured Warrants and your return from the Structured Warrants.

- Suspension of trading in the Underlying Equity or Underlying ETF and/or Structured Warrants

If the trading in any of the Underlying Equity or Underlying ETF is suspended, then trading in the Structured Warrants on Bursa Securities may be suspended for a similar period. If our Structured Warrants are not suspended by Bursa Securities, we may also request for a suspension of our Structured Warrants. You should be aware that the closing price of the Underlying Equity or Underlying ETF for the calculation of Cash Settlement Amount may vary if you intend to exercise your Structured Warrants during such suspension in the trading of the Underlying Equity or Underlying ETF.

- Possible early termination for illegality or impracticality

If we determine that the performance of our obligations under the Structured Warrants has become illegal or impractical in whole or in part, we may as we reasonably deemed fit, terminate the Structured Warrants early and pay you an amount if the Cash Settlement Amount after deducting all exercise expenses is greater than zero in accordance with the terms of the Deed Poll. Such early termination could cause you to suffer a loss or achieve a reduced profit.

- Implications of the Take-Over Rules

You should bear in mind the implications of Rule 4, Part B of the Take-Over Rules and Sections 217 and 218 of the CMSA. These provisions generally regulate the acquisition of effective control of Malaysian public companies and you should consider the implications of these provisions before you buy and/or exercise the physical-settled Structured Warrants. If you have obtained control in the Underlying Company or triggered the creeping threshold (i.e. acquired more than 2% of shares of the Underlying Company in any period of 6 months when you already hold more than 33% but below 50% of shares of the Underlying Company) by buying and/or exercising physical-settled Structured Warrants, you are required by the Take-Over Rules to make a mandatory take-over offer on the Underlying Company.

Risks relating to the Underlying Companies, Underlying Equities, Underlying ETFs and Underlying Indices:-

- Inherent risks relating to the Underlying Companies

You should note that the occurrence of any material or adverse events in the industries of the Underlying Companies, may affect the performance of the relevant Underlying Equities and/or Underlying ETFs on the relevant Securities Exchanges, which may consequentially affect the value and/or performance of our Structured Warrants.

3. PROSPECTUS SUMMARY (cont'd)

- Limited information on the Underlying Companies, Underlying Equities, Underlying ETFs or Underlying Indices

Information and statements to be disclosed in the relevant Term Sheets such as the price or level relating to the Underlying Companies, Underlying Equities, Underlying ETFs and Underlying Indices will be obtained or extracted from publicly available third party sources such as a financial news service provider or financial information network provider. There can be no assurance on the timeliness, completeness of disclosure or availability of critical or material information obtained from these third party sources, and we have not independently verified such information. You should make your own enquiries, and where appropriate, obtain prior advice in relation to any investment decision.

- Take-over offer or compulsory acquisition of the Underlying Companies

In the event of a take-over offer or compulsory acquisition of equities in an Underlying Company, no cancellation of the relevant Structured Warrants shall be effected and the Structured Warrants shall remain exercisable by the Holder for the remaining tenure of the exercise period unless such take-over offer or compulsory acquisition results in the delisting, liquidation, dissolution or winding-up of the Underlying Company.

- Merger or consolidation of the Underlying Companies

In the event of a merger, amalgamation or reconstruction of the Underlying Company wherein an Underlying Company may merge with or into any other corporation, consolidate with or into any other corporation or sell or transfer all or substantially all of its assets, we may in good faith cancel the Structured Warrants and settle in cash if the Cash Settlement Amount after deduction of the exercise expenses, if any, is more than zero or make any adjustments to the rights attaching to the relevant Structured Warrants, in accordance with the terms of the Deed Poll. Hence, there is a risk that the Structured Warrants may be cancelled before the expiry date and cause the Holder to suffer a loss or achieve a reduced profit.

- Delisting of Underlying Equities or Underlying ETFs and liquidation, dissolution or winding-up of the Underlying Companies or Underlying ETFs

If there is a delisting of the Underlying Equities or Underlying ETFs, or liquidation, dissolution or winding-up of the Underlying Companies or the Underlying ETFs, or a liquidator, receiver or administrator is appointed with respect to substantially the whole of the Underlying Companies' assets or the Underlying ETFs' assets or to wind-up the Underlying Companies or Underlying ETFs, it is possible that the Structured Warrants will be terminated before the expiry date of the Structured Warrants without the Holders' expectations being realised.

- Composition of indices

The composition of an index is determined by the Underlying Index Sponsor and may be changed to reflect prevailing circumstances. You should be aware that changes in the composition of indices such as inclusion of new companies into an index or changing the companies' weighting in an index by the Underlying Index Sponsor may have an adverse impact on the relevant Underlying Indices and consequently, on the price of the relevant Structured Warrants.

- Compliance with the relevant laws and regulations by the Underlying Companies, the Underlying Index Sponsor or the Underlying ETFs

The performance of the relevant Underlying Equities and/or Underlying ETFs on the relevant Securities Exchanges may be affected due to failure to comply with relevant laws and regulations, which may consequentially affect the value and/or performance of our Structured Warrants. You should make your own enquiries, and where appropriate, obtain prior advice in relation to any investment decision.

- Determining the Underlying Index level

Certain events relating to the Underlying Index (including a material change in the calculation of the Underlying Index level or a failure to publish the Underlying Index level) permit us to :-

- (a) determine the Underlying Index level on the basis of the formula or method of calculating the Underlying Index last in effect prior to such change; or

3. PROSPECTUS SUMMARY *(cont'd)*

- (b) determine the Underlying Index level on the basis of the level of futures relating to the relevant index.

Such changes may result in changing the companies' weighting in an index, the inclusion of new companies into an index and/or the removal of companies from an index. You should be aware that changes in the composition of indices may have an adverse impact on the relevant Underlying Index and the price of the relevant Structured Warrants.

- Risks relating to ETFs / ETF Structured Warrants / Underlying ETF Assets

ETFs may have different or additional risks and considerations compared to other types of Underlying Instruments. Some of these risks and considerations may include (but are not necessarily limited to) the following:-

- (a) For an index-tracking fund, the Underlying Index Sponsor may make an adjustment of the method for calculation of an index, which could adversely affect the value of the ETF and hence the price of the Structured Warrants;
- (b) Some ETFs may not track the performance of the target index exactly because their holdings of assets may not exactly match the constituents of the target index. This may lead to a discrepancy between the performance of the target index and the performance of the ETF, and consequentially the performance of the Structured Warrants;
- (c) ETFs may invest in a wide range of underlying assets including stocks, bonds, cash, commodities, currencies or derivatives in accordance with the objectives of the ETFs. As such, the performance of the ETF and the Structured Warrants will reflect the risks and characteristics of the different underlying assets that the ETF invests in;
- (d) The price of an ETF may trade at a premium or discount to the ETF's net asset value due to supply and demand in the trading of the ETF. Hence the value of Structured Warrants may not exactly match the performance of the ETF's net asset value; and
- (e) The ETF may allow for creation or redemption of ETF units after the initial listing of the ETF which will potentially affect the balance of market supply and demand of the ETF. The market supply and demand of ETF will affect the performance of the ETF, and consequentially the price of the Structured Warrants.

Other risks:-

- Delay in or abortion of the listing of our Structured Warrants

The occurrence of certain events, including the following, may cause a delay in or abortion of the Listing of each series of our Structured Warrants:-

- (a) we are unable to meet the public spread requirement as stipulated by Bursa Securities where each series of the Structured Warrants must be held by at least hundred (100) Holders holding not less than one (1) board lot of the relevant series of Structured Warrants each, or at least fifty (50) Holders holding not less than one (1) board lot each provided that each of these Holders subscribes for a minimum of RM100,000 of the relevant series of Structured Warrants each, or such other public spread requirement of Bursa Securities as amended from time to time is not met; or
- (b) the minimum subscription of a total face amount of RM5 millions of our Structured Warrants, or such other minimum subscription face amount as required by Bursa Securities from time to time, is not met.

For Structured Warrants issuance made by way of placement, where you have made payment for the application of the Structured Warrants prior to its Listing, the delay in the Listing of the Structured Warrants may cause opportunity lost to you, amongst others, where the movement in price / level of the Underlying Instruments are in your favour and you would not be able to realize the gain in Structured Warrants. In the event that we have to abort the Listing of the Structured Warrants, the monies paid in respect of your application will be returned to you without reimbursement of interest payment.

- Political and economic factors

Adverse local and abroad political and economic conditions or developments, which include an

3. PROSPECTUS SUMMARY *(cont'd)*

unstable political environment, nationalisation (i.e. the transfer of a private asset or industry to the public ownership or control of a government or state) and severe fluctuations in interest and currency exchange rates, may create uncertainty and could discourage the free flow of investment capital. These would affect international trade and ultimately resulting in adverse developments in economic activity. Subsequently, these may have material adverse impact on the financial performance and/or business prospects of Underlying Companies. The same factors may also materially and adversely affect the performance of the Underlying Indices or Underlying ETFs. Such factors may negatively impact the price/level of the Underlying Instruments and consequentially may affect the price of the Structured Warrants.

- Settlement Disruption Event and Market Disruption Event

You should note that the occurrence of a Market Disruption Event can delay the determination of the closing price and consequently the payment of the Cash Settlement Amount or delivery of the Physical Settlement Amount to you upon exercise of the Structured Warrants. The occurrence of a Settlement Disruption Event will also delay the payment of the Cash Settlement Amount or delivery of the Physical Settlement Amount to you upon exercise of the Structured Warrants. Subject to the terms of Deed Poll, the occurrence of a Market Disruption Event shall entitle us to determine as we reasonably deem fit, the closing price, exchange rate and/or valuation period for the relevant Structured Warrants which consequently may adversely affect the Cash Settlement Amount or Physical Settlement Amount.

- Exchange rate risks

There will be exchange rate risk when the Underlying Instrument is denominated in foreign currency and the Cash Settlement Amount is converted into RM. The conversion may potentially result in foreign exchange losses if there is any adverse movement of the exchange rate. Any foreign exchange losses will be borne by the Holders.

- Foreign law / regulatory policy risks

Where the Underlying Companies or the Underlying Instruments involve companies or indices or shares in a market outside of Malaysia which have legal and regulatory regimes different from that of Malaysia, your investment in the relevant Structured Warrants may be exposed to greater risks through changes in law and regulatory policies as compared with Structured Warrants investments which are only in respect of Malaysian securities.

You should be aware that the performance of the relevant Underlying Equities and/or Underlying ETFs on the relevant Securities Exchanges may be affected due to failure to comply with relevant laws and regulations by the Underlying Companies, the ETF Manager or the Underlying Index Sponsor, which may consequentially affect the value of the Structured Warrants.

- Nationalisation

Nationalisation involves the transfer of a private asset or industry to the public ownership or the control of a government or state. If nationalisation occurs in relation to the relevant Underlying Company:-

- (a) we retain the discretion to determine the appropriate adjustment, if any, to be made to any one or more of the Conditions of Annexure I to this Base Prospectus to account for the nationalisation and determine the effective date of that adjustment. We may, but are not obliged to, determine the appropriate adjustment by reference to the terms of the Deed Poll; or
- (b) the Structured Warrants may be early exercised and settled in cash if it is in-the-money at the relevant time; or
- (c) we retain the discretion to refrain from taking any action where the Underlying Equities and/or Underlying ETFs of such Underlying Companies continue to be listed at the relevant Securities Exchange(s).

- Potential Tax Implications

The buy and sell transactions of Structured Warrants on Bursa Securities are subjected to stamp duty. In addition, income tax or capital gain tax treatment may vary depending on the legal identity of an investor, or the classification of income from the investment of Structured Warrants by the relevant tax authorities.

3. PROSPECTUS SUMMARY *(cont'd)*

From time to time, tax laws and regulations as well as their application by the relevant taxation authorities are subjected to changes. If you are in doubt, please consult your own independent tax advisers on your tax position considering your individual circumstances before investing in Structured Warrants.

- COVID-19 endemic and possible similar future outbreaks

The ongoing COVID-19 endemic and any possible future outbreaks of disease may have significant adverse effect on the financial and business prospects of an Underlying Company, the performance of the Underlying Equities, Underlying Indices or Underlying ETFs and consequentially affect the price of the Structured Warrants.

- Combination of risk factors

Two (2) or more risk factors may simultaneously have an effect on the value of a Structured Warrant. As such, the effect of any combination of risk factors on the value of the Structured Warrants may be unpredictable.

Further information on the risk factors are set out in Section 6 of this Base Prospectus.

3.5 Risk Management

Group Risk Management Division is independent of the various business units and acts as the catalyst for the development and maintenance of comprehensive and sound risk management policies, strategies and procedures within our Group wherein the Board plays a vital role in approving policies set for the Group. Group Risk Management Division comprises Wholesale Credit Risk, Business Credit Risk, Retail Credit Risk, Investment Banking and Markets Risk, Group Operational Risk, Group Technology Risk, Portfolio Risk Management (which is responsible for the development of credit models), Credit Model Validation and Independent Credit Review departments.

3.5.1 Risk Management Governance

Our Board is ultimately responsible for the management of risks within our Group. Our Risk Management Committee ("**RMC**") comprises three (3) members, all of whom are Non-Executive Directors and is chaired by an Independent Non-Executive Director. RMC is formed to assist our Board in discharging its duties in overseeing the overall management of credit, market, liquidity, operational, technology and cyber security, legal, capital, regulatory compliance, shariah and reputational risks impacting the Group.

Our Board has also established management risk committees to assist it in managing the risks and businesses of our Group. The Group's risk management function is independent of the Group's business and is headed by the Group Chief Risk Officer who reports directly to the Board.

3.5.2 Risk Management Approach

The following are the risks which our Group is generally exposed to:-

- Business risk;
- Capital risk;
- Market risk;
- Liquidity risk and funding management;
- Credit risk;
- Operational risk;
- Technology and cyber security risk;
- Legal risk;
- Regulatory compliance risk; and
- Reputational risk.

Further information on our risk management framework and risk strategy are set out in Section 4.9 of this Base Prospectus.

4. INFORMATION ON AMBANK

4.1 Background and Business

4.1.1 Background and brief history

AmBank is a public limited company incorporated in Malaysia on 25 March 1969 under the Act with the registration number of 196901000166 (8515-D) and the name of Malaysia Borneo Finance Corporation (M) Berhad. It changed its name to MBf Finance Berhad ("**MBf Finance**") on 19 December 1985.

On 3 April 2002, MBf Finance changed its name to AmFinance Berhad. The name change was prior to the transfer of the entire business of AMFB Holdings Berhad (formerly known as Arab-Malaysian Finance Berhad and now dissolved) to AmFinance Berhad which was effected on 15 June 2002. AmBank assumed its present name, AmBank (M) Berhad, on 1 June 2005 upon the merger of AmFinance Berhad and AmBank Berhad.

AmBank is a licensed commercial bank under the FSA and is regulated by BNM. It offers commercial banking services which include loans and financing, deposit services, credit cards, remittance and foreign exchange services which focused on retail, corporate and institutional customers.

4.1.2 Business Operations Review

The Group's banking activities comprises the following main segments: (a) Wholesale Banking, (b) Retail Banking, (c) Business Banking and (d) Group Funding and Capital and Balance Sheet Management. The Structured Warrant business falls under the Group Treasury & Markets division of the Wholesale Banking segment.

(a) Wholesale Banking

Wholesale Banking caters for the banking needs of large corporations from various economic sectors and industries, as well as institutional clients, government-linked companies and agencies. Business solutions experts, supported by client coverage teams, offer our clients a range of services that can help meet their diverse needs. These include cash management, trade solutions, financing, foreign exchange, remittance, investments, treasury, debt and equity markets solutions which are offered through three main divisions:

Corporate Banking

Corporate Banking offers a range of products and services, including corporate lending, investment banking advisory, trade finance, offshore banking and cash management solutions to wholesale banking clients.

*Group Treasury and Markets ("**GTM**")*

GTM manages liquidity for the banking group and offers financial market and hedging solutions across all asset classes to a broad range of clients. The sales and trading activities cover fixed income, interest rates, foreign exchange, money market, equity derivatives, commodities and other derivatives.

The Equity Derivatives unit is responsible for issuance, sales, and market-making of Structured Warrants, equity options and equity-linked structured investments. It is also engaged in providing equity structured solutions cater to high net-worth individual, corporate, and institutional clients.

Transaction Banking

Transaction Banking delivers tailor-made digital and cash management solutions, as well as trade financing and remittance services, to corporate clients and small and medium sized enterprises ("**SMEs**").

4. INFORMATION ON AMBANK (cont'd)

(b) Retail Banking

Retail Banking provides everyday banking solutions to individuals and SMEs customers, covering both conventional and Islamic financial products and services. These financial products and services include:-

- Residential Mortgages
- Business Premises Loans / Financing
- Portfolio Guarantees and Unsecured Financing for SMEs
- Auto Finance – motor vehicles for personal and commercial use
- Secured Personal Loans / Financing
- Unsecured Personal Loans / Financing
- Credit Cards
- Wealth Management and Bancassurance
- Remittance and FX Services
- Deposits and Internet Banking Services
- Merchant Business Solutions

Residential Mortgages

Residential Mortgages comprise the largest asset lending / financing portfolio of AmBank. In AmBank, we offer a range of residential mortgage products to finance the purchase of residential properties in the primary and secondary housing market. Our products ranges from the basic term loans / financing to Homelink, a flexiloan which enables customers to save more on the loan interest when they keep more funds in the integrated current account. Currently, there are a total of 3 Residential Mortgage products offered to customers, namely Home Loan, Home Financing-I and Home Link. Additionally, AmBank may offer Overdraft and/or Cashline-I secured against property to help customers with their financial needs.

Business Premises Loans / Financing

AmBank offers Business Property Financing, with various flexibilities in terms of products and payment options to facilitate the customer's purchase of non-residential properties including shop-houses, retail lots, office lots, factories and vacant land.

Portfolio Guarantees and Unsecured Financing for SMEs

AmBank offers working capital financing to assist SMEs with additional cash flow and/or business expansion. In addition, AmBank provides assistance to eligible SMEs with additional working capital via various relief schemes such as Targeted Relief Recovery Facility, Penjana Tourism Facility and Disaster Relief Facility. Targeted Relief Recovery Facility provides relief and support recovery for SMEs in the services sector (excepts tourism and tourism related sectors) that are affected by the reintroduction of containment measures since June 2020 and the Penjana Tourism Facility is aimed to support SMEs in the tourism sector by preserving their capital and assisting them to adjust and remain viable post COVID-19. The Disaster Relief Facility alleviates the financial burden of SMEs affected by floods and enable them to resume their business operations.

Meanwhile, AmBank also provide Industrial Hire Purchase for eligible SMEs covering different equipment classes.

Auto Finance – motor vehicles for personal and commercial use

Auto Finance is a core Retail Banking lending business, which is currently being offered to individuals, non-individuals and car dealerships, namely Hire Purchase Fixed Rates, Hire Purchase Fixed Rates – i, Hire Purchase Variable Rates, Hire Purchase Variable Rate - i and Capital Financing. AmBank offers approval to customers applying for financing using the Mobile Application Terminal.

Secured Personal Loans / Financing

AmBank offers term loans / financing that diversifies from its retail banking portfolio as this term loan / financing is offered to our customers for the purpose of financing their purchase of Amanah Saham Bumiputera units.

Unsecured Personal Loans/ Financing

4. INFORMATION ON AMBANK *(cont'd)*

AmBank provides unsecured personal loan – AmMoneyLine to offer our consumers Cash Out Plan and Debt Consolidation Plan based on their needs.

Credit Cards

AmBank continues its focus on key cardholder segmentations of affluent segment, emerging affluent segment and the mass-market segment by offering card benefits which suits the different segments of its cardholders.

Wealth Management and Bancassurance

The Group offers Wealth Management solution catering to clients' financial wealth solution needs from three major aspect of investment, protection and wealth distribution needs. We offer investment solutions such as unit trusts, structured investments and retail bonds, protection solutions for life protection, credit protection, savings endowment, investment-linked plan, child education, medical/critical illness coverage, retirement needs, motor insurance, houseowner & householder, personal accident plans, home content and travel insurance, among others.

Remittance and FX Services

Ambank offers a range of money transfer remittances services to cater for customers sending and receiving money for over 20 major foreign currencies at our branches.

Deposits and Internet Banking Services

AmBank offers current accounts, savings accounts, foreign currency accounts and fixed deposits which are available in both conventional and Islamic variants. Our deposit products are available to both individual and non-individual customers. Our current and savings account enables customers to link to their AmEquities Trading Account to enable them to make share purchases seamlessly.

Our AmOnline internet banking and mobile banking services offer easy, simple, and secure digital banking solutions to our customers, in 3 languages. Our customers can conduct their everyday banking transactions such as bill payments, fund transfers, scheduled and repeat transactions, application of card, savings account or fixed deposit and many other banking services at their convenience, without having to visit our branches.

Customers can now open their current or savings account online and start a banking relationship with us.

Merchant Business Solutions

Ambank Merchant Business Solutions offer credit cards, debit cards, e-wallet and QR payment processing for our merchant partners through various channels such as over-the-counter, bank payment gateway, recurring payment and more subject to the needs and requirements of the merchant partners.

We support the processing of all major card schemes and e-wallet brands transaction and we facilitate our merchant partners to operate their businesses with the latest payment acceptance technology and tools. Hence, we provide an effective platform to leverage on for business growth through various possible collaborations such as SME loans, cards usage campaign and many more.

(c) Business Banking

Our Business Banking division was launched in April 2017 to service Malaysia's emerging SMEs. The creation of Business Banking is also in keeping with our national agenda and strategic initiative to nurture entrepreneurs that will contribute to Malaysia's economy.

The Business Banking division comprises two segments, namely: Enterprise Banking ("EB") and Commercial Banking ("CB"). EB serves customers with annual turnovers between RM1 million to RM 50 million where else CB serves customers with annual turnovers of more than RM50 million.

Business Banking supports the needs of our customers by providing a range of products and solutions such as Commercial Lending, Enterprise Lending, Business Wealth, Industrial Hire Purchase and Bancassurance.

4. INFORMATION ON AMBANK (cont'd)

Business Financing Solutions

- Business Banking offers a range of schemes such as financing for business premises and equipment purchases to more complex financing that allow for a combination of capital expenditure and working capital needs.
- Business Banking also structures products to cater to its customers. Such products include working capital, bridging financing, contract financing and other specialised loans.
- The contract financing facilities offered by AmBank can be tailored for a specific project or contract. The financing package varies in accordance to the type of contract, such as construction, services, or supply-based projects. AmBank also provides financing for import and export transactions, particularly for businesses in the auto parts and food-related industries.

Portfolio Guarantee (“PG”) Scheme

- The scheme provides SMEs with financing of up to RM1 million and financing tenure of up to seven years.
- The PG Scheme does not require collaterals or charge credit guarantee fees and has a shorter turnaround time due to its simplified lending process.

Business Wealth

- Business Banking has a dedicated team of Relationship Managers that focus specifically on helping businesses manage their wealth, meet their financial goals and objectives.

Business Bancassurance

- Business Banking offers solutions that help customers protect their business from financial losses and/or damages resulting from unforeseen events such as death or total and permanent disability of key personnel.
- Bancassurance solutions include:-
 - (i) Reducing Term Assurance/Reducing Term Takaful - A single premium (one time payment/single premium) coverage that provides protection with reducing sum covered (yearly reducing of sum assured) throughout the coverage period in the event of death or total permanent disability.
 - (ii) Level Term Assurance/Level Term Takaful (“LTA/LTT”) - A single premium (one time payment/single premium) coverage that provides protection with level sum coverage (same sum assured) throughout the coverage period in the event of death or total permanent disability.
 - (iii) Level Term Assurance with Refund of Premium/Level Term Takaful with Refund of Contribution – LTA/LTT with the exception that the single premium/contribution can be refunded to the customer upon expiry of the coverage period.

(d) Group Funding and Capital and Balance Sheet Management

Group Funding and Capital and Balance Sheet Management comprise activities to manage the Group’s capital, liquidity, funding, funds transfer pricing and overall balance sheet risk of the Group.

Capital Management

AmBank Group’s capital management approach remains focused on maintaining an optimal capital position that supports the Group’s strategic objectives and risk appetite. This is achieved through building an efficient capital structure that optimises return on capital and provides sustainable returns to shareholders.

Effective capital management is essential to the sustainability of the Group and involves:

- Meeting regulatory capital requirements at all times;
- Supporting the Group’s risk appetite, business growth and strategic objectives; and
- Achieve or maintain the desired credit rating.

4. INFORMATION ON AMBANK (cont'd)

Balance Sheet Management

Balance sheet management involves the management of the Group's funding and liquidity and implementation of the Funds Transfer Pricing ("FTP") framework. Balance sheet management matters are under the purview of the Group Assets and Liabilities Committee.

Funding and liquidity are managed by targeting a diversified funding base and avoiding concentrations by depositor and investor type, product, maturity or currency and implementing wholesale funding diversification and maturity concentration limits. In setting its funding diversification policy, the Group will take into consideration the cost/benefit trade-off to ensure optimum level of funding cost. Funding cost is the interest rates paid for procuring deposits, money market funds and medium term borrowings.

To sustain a diversified funding profile and monitor the liquidity risk of the Group, we are guided by the Basel III liquidity framework, namely the:

- Liquidity Coverage Ratio, with a primary focus of ensuring a sufficient buffer of liquid assets that could be easily converted into cash to meet the liquidity needs for up to 30 calendar days; and
- Net Stable Funding Ratio, outlining the requirements on maintaining stable funding profile vis-à-vis the composition of assets and off-balance sheet commitments in order to reduce likelihood of disruption to liquidity position.

The FTP is the process of assigning a market-based contribution value to the sources and applications of funds.

The FTP framework promotes a Group-wide allocation of funding costs to the business units by taking into account the interest rate and liquidity positions of the Group. The FTP mechanism is refined according to market conditions and relevant strategies approved by the management and it is derived to reflect regulatory principles.

Presently the key funding growth agenda is as follows:-

- to proactively manage the Loans-to-Deposits Ratio to ensure that the bank has sufficient funds before lending;
- to strengthen the deposit structure mix, by focusing on growing low-cost current accounts and savings accounts and longer duration term deposits to build sufficient base to fund the loans growth; and
- to diversify the sources of funding to build a more sustainable base by targeting to grow deposits from individuals and small businesses, operational deposits and reduce reliance on non-core deposits such as deposits from banks and non-bank financial institutions.

[The rest of this page has been intentionally left blank]

4. INFORMATION ON AMBANK (cont'd)**4.2 Share Capital**

As at LPD, our share capital is as follows:

	No. of shares	Amount (RM '000)
Share capital:		
Ordinary shares	949,927,564	3,040,465

4.3 Rating Profile

As stated in Section 6.1.1 of this Base Prospectus, you will be taking on our credit risk if you purchase the Structured Warrants. You must therefore make your own assessment of the credit risk associated with dealing with us.

Our RAM Ratings' rating history is as follows:-

Financial Institution Ratings	November 2020	March 2021	January 2022	January 2023
Long Term (Outlook)	AA ₂ (Stable)	AA ₃ (Stable)	AA ₃ (Stable)	AA ₃ (Positive)
Short Term	P1	P1	P1	P1

Note:-

The definitions of the respective ratings are as follows:-

Rating Definition

- AA** A financial institution rated AA has a strong capacity to meet its financial obligations. The financial institution is resilient against adverse changes in circumstances, economic conditions and/or operating environments.
- P1** A financial institution rated P1 has a strong capacity to meet its short-term financial obligations. This is the highest short-term financial institution rating assigned by RAM Ratings.

For long-term ratings, RAM Ratings applies subscripts 1, 2 or 3 in each rating category from AA to C. The subscript 1 indicates that the financial institution ranks at the higher end of its generic rating category; the subscript 2 indicates a mid-ranking; and the subscript 3 indicates that the financial institution ranks at the lower end of its generic rating category.

On 5 March 2021, RAM Ratings has downgraded our rating due to the financial impact of the RM2.83 billion global settlement made by AMMB to the Government in relation to its historical dealings with 1Malaysia Development Berhad. As a result of the demonstrable improvement in the capitalisation of AMMB and all its subsidiaries and associate companies including but not limited to AmBank, our rating has been revised from stable to positive on 10 January 2023. Any revision of our credit rating may have an impact on our credit risk.

Please refer to Section 6.1.1 on page 49 of this Base Prospectus in relation to the credit risk.

[The rest of this page has been intentionally left blank]

4. INFORMATION ON AMBANK (cont'd)**4.4 Our Board**

As at LPD, our Board comprises the following:-

Name	Designation
Voon Seng Chuan	Chairman / Independent Non-Executive Director
Soo Kim Wai	Non-Independent Non-Executive Director
Dato' Sri Abdul Hamidy bin Abdul Hafiz	Independent Non-Executive Director
Dr Veerinderjeet Singh a/l Tejwant Singh	Independent Non-Executive Director
U Chen Hock	Independent Non-Executive Director
Ng Chih Kaye	Independent Non-Executive Director
Foong Pik Yee	Independent Non-Executive Director

4.5 Our key management team

Our key management team as at the LPD is as follows:-

Name	Designation
Dato' Sulaiman Mohd Tahir	Group Chief Executive Officer
Ling Fou-Tsong @ Jamie Ling	Group Chief Financial Officer
Datuk Iswaraan Suppiah	Group Chief Operations Officer
Faradina Binti Mohammad Ghouse	Group Chief Compliance Officer
Jeroen Petrus Margaretha Maria Thijs	Group Chief Risk Officer
Shamsul Bahrom Bin Mohamed Ibrahim	Group Chief Internal Auditor
Rohani Mustaffa	Group Chief Human Resource Officer
Aaron Loo Boon Seng	Managing Director, Retail Banking
Christopher Yap Huey Wen	Managing Director, Business Banking
Jamzidi Khalid	Managing Director, Wholesale Banking

4.6 Management

Our Group's overall supervision is led by our Board with the support from our key management personnel which comprises professional and experienced persons who are delegated with the necessary authority to manage their respective departments. Our key management personnel possess relevant experience in the banking and finance industry and play an important contributory role to the progress and development of the Group.

4. INFORMATION ON AMBANK (cont'd)

4.7 Our Group

4.7.1 Our Group structure

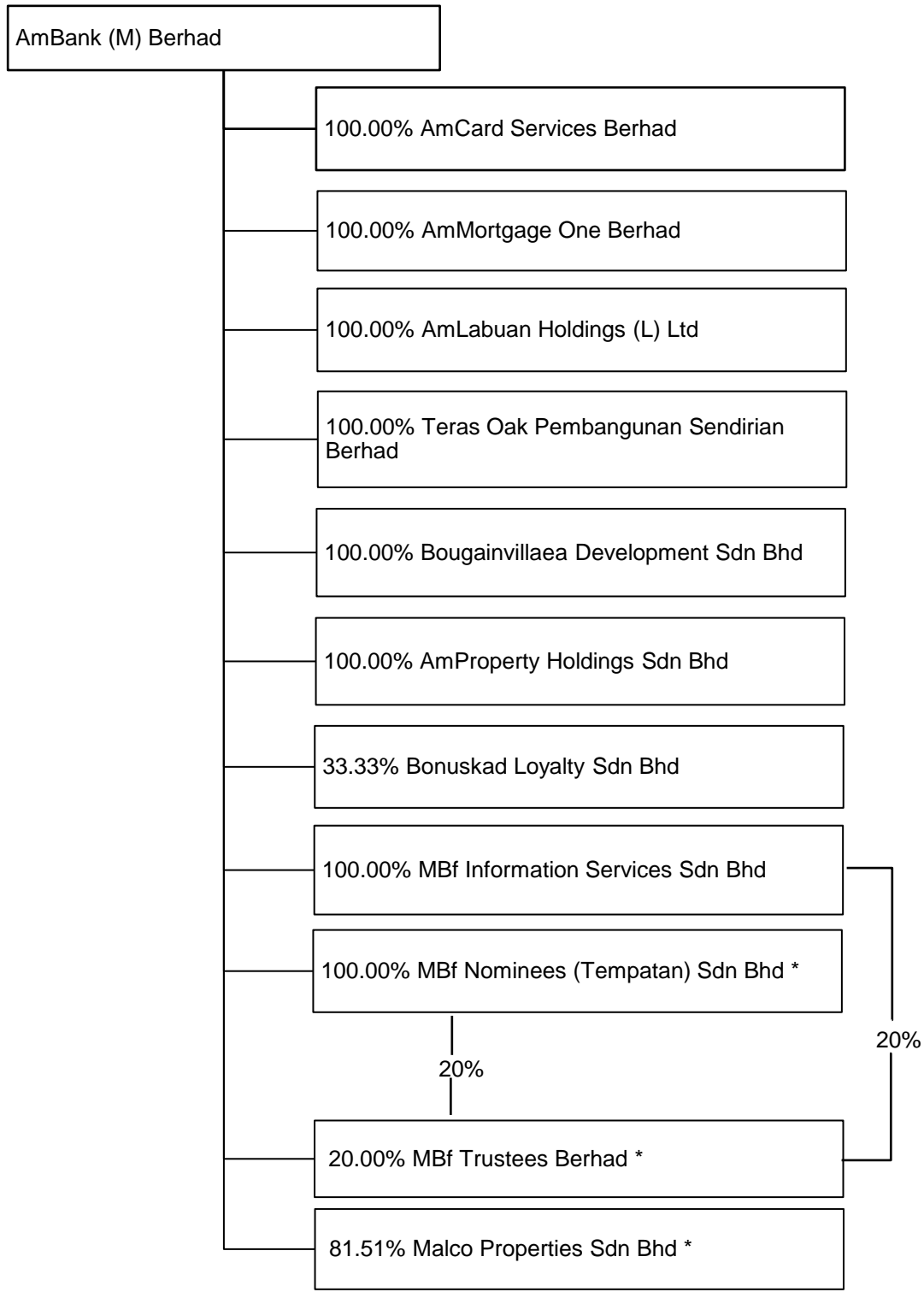

Note:-

* Subsidiary in liquidation

4. INFORMATION ON AMBANK (cont'd)**4.7.2 Subsidiaries and Associate Company**

Details of our subsidiaries as at the LPD are as follows:-

Company	Registrati on No.	Date and place of Incorporat ion	Issued and paid- up capital RM (unless otherwise stated)	Effective equity Interest (%)	Principal Place of Business	Principal activities
Bougainvillaea Development Sdn Bhd	198201005 784 (85538-X)	31.05.1982 Malaysia	2,000,000	100.00	17 th Floor Bangunan AmBank Group No. 55 Jalan Raja Chulan 50200 Kuala Lumpur Wilayah Persekutuan	Property investment
MBf Information Services Sdn Bhd	199001002 297 (193860-V)	22.02.1990 Malaysia	2,000,000	100.00	17 th Floor Bangunan AmBank Group No. 55 Jalan Raja Chulan 50200 Kuala Lumpur Wilayah Persekutuan	Property investment
MBf Nominees (Tempatan) Sdn Bhd ⁽²⁾	197401001 424 (18483-H)	09.05.1974 Malaysia	10,000	100.00	NIL	Dormant
AmProperty Holdings Sdn Bhd	199101012 481 (222793-A)	12.08.1991 Malaysia	500,000	100.00	17 th Floor Bangunan AmBank Group No. 55 Jalan Raja Chulan 50200 Kuala Lumpur Wilayah Persekutuan	Property investment
MBf Trustees Berhad ⁽²⁾	199201001 907 (233411-M)	29.01.1992 Malaysia	250,000 ⁽¹⁾	60.00	NIL	Dormant
Teras Oak Pembangunan Sendirian Berhad	197701003 944 (34988-H)	22.09.1977 Malaysia	4,700,000	100.00	NIL	Dormant
Malco Properties Sdn Bhd ⁽²⁾	198001001 890 (55673-D)	29.02.1980 Malaysia	416,502	81.51	NIL	Dormant

4. INFORMATION ON AMBANK (cont'd)

Company	Registrati on No.	Date and place of Incorporat ion	Issued and paid- up capital RM (unless otherwise stated)	Effective equity Interest (%)	Principal Place Business	of	Principal activities
AmLabuan Holdings (L) Ltd	LL00365	12.01.1995 Labuan	USD1,000	100.00	Level 12(B), Block 4 Office Tower, Financial Park Labuan Complex, Jalan Merdeka, 87000, F.T., Labuan, Malaysia		Investment holding
AmMortgage One Berhad	200901003 517 (846444-U)	12.02.2009 Malaysia	1,000	100.00	Level 30, Menara AmBank No. 8, Jalan Yap Kwan Seng 50450 Kuala Lumpur Wilayah Persekutuan		Undertakin g securitisi on transacti ons
AmCard Services Berhad	198101000 277 (66382-D)	10.01.1981 Malaysia	1,000,000	100.00	17 th Floor Bangunan AmBank Group No. 55 Jalan Raja Chulan 50200 Kuala Lumpur Wilayah Persekutuan		Outsourcin g servicer for mortgage related services

[The rest of this page has been intentionally left blank]

4. INFORMATION ON AMBANK (cont'd)

Details of our associate company as at the LPD are as follows:-

Company	Registration No.	Date and place of Incorporation	Issued and paid-up capital RM (unless otherwise stated)	Effective equity Interest (%)	Principal Place of Business	Principal activities
Bonuskad Loyalty Sdn Bhd	1997010227 03 (438200-T)	05.07.1997 Malaysia	1,302,601 (1,005,402 preference shares and 297,199 ordinary shares)	33.33	Level 8, Block C Menara Glomac Kelana Business Centre Jalan SS7/2, Kelana Jaya Petaling Jaya 47301 Selangor	Carrying on business of customer loyalty schemes as principal or agents on behalf of companies participating in such schemes

Notes:-

- 1 Issued share capital comprises 50,000 ordinary shares of RM10 each, paid-up to RM5 each in accordance with Section 3(c) of the Trust Companies Act 1949.
- 2 Subsidiary under members' voluntary winding-up.

[The rest of this page has been intentionally left blank]

4. INFORMATION ON AMBANK (cont'd)**4.8 Financial Highlights**

The following financial information is based on our audited consolidated financial statements for the FYE 31 March 2021, FYE 31 March 2022, FYE 31 March 2023 and unaudited consolidated financial statements for the three (3) months FPE 30 June 2023.

Consolidated statements of profit or loss

	←-----FYE 31 March-----→			Unaudited 3-months FPE 30 June 2023 (RM'000)
	2021 (RM'000)	2022 (RM'000)	2023 (RM'000)	
Interest income	4,008,681	3,940,247	5,059,927	1,510,341
Interest expense	(2,061,934)	(1,784,418)	(2,713,306)	(959,119)
Net interest income	1,946,747	2,155,829	2,346,621	551,222
Other operating income	717,252	540,756	673,920	210,348
Share in results of an associate	(1,319)	(708)	2,798	(7)
Net income	2,662,680	2,695,877	3,023,339	761,563
Other operating expenses	(1,282,516)	(1,300,780)	(1,428,435)	(329,986)
Operating profit	1,380,164	1,395,097	1,594,904	431,577
Allowance for impairment on loans and advances	(589,570) ⁽ⁱ⁾	(72,066)	(258,991)	(132,868)
(Provision)/writeback of provision for commitments and contingencies	(47,860)	(174,204)	85,280	(3,948)
Impairment (loss)/writeback on:-				
Financial investments	(17,138) ⁽ⁱ⁾	(14,279)	(1,344)	(12,664)
Other financial assets	569	(1,273)	993	(2,467)
Other recoveries, net	8,116	171	527	4
Apportionment of settlement cost	(2,535,000)	-	-	-
(Loss)/profit before taxation	(1,800,719)	1,133,446	1,421,369	279,634
Taxation	(162,574)	(119,824)	(327,632)	(60,327)
(Loss)/profit for the financial year/period	(1,963,293)	1,013,622	1,093,737	219,307
Attributable to:				
Equity holder of the Bank	(1,963,285)	1,013,622	1,093,738	219,307
Non-controlling interests	(8)	-	(1)	-
(Loss)/profit for the financial year/period	(1,963,293)	1,013,622	1,093,737	219,307
(Loss)/earnings per share (sen)				
Basic/diluted	(234.50)	107.57	115.14	23.09

4. INFORMATION ON AMBANK (cont'd)**Consolidated statements of comprehensive income**

	←-----FYE 31 March-----→			Unaudited 3-months FPE 30 June 2023 (RM'000)
	2021 (RM'000)	2022 (RM'000)	2023 (RM'000)	
(Loss)/profit for the financial year/period	(1,963,293)	1,013,622	1,093,737	219,307
Other comprehensive income/(loss):				
Items that will not be reclassified subsequently to statements of profit or loss				
<u>Equity instruments</u>				
Financial investments at fair value through other comprehensive income				
- net changes in fair value	96,474	(5,250)	(1,085)	38,308
Tax effect	(883)	1,982	2,202	-
Items that may be reclassified subsequently to statement of profit or loss				
Currency translation on offshore operations	(11,178)	3,900	13,342	15,337
Cash flow hedge				
- gain arising during the financial year	5,615	1,654	-	-
- amortisation of fair value changes of terminated hedge	9,130	8,724	6,320	1,576
Tax effect	(3,539)	(2,491)	(1,517)	(378)
<u>Debt instruments</u>				
Financial investments at fair value through other comprehensive income				
- net unrealised gain/(loss) on changes in fair value	19,266	(198,928)	7,883	14,910
- net gain reclassified to statements of profit or loss	(23,492)	(4,218)	(286)	130
- expected credit loss	(3,553)	2,322	(1,111)	9,626
- foreign exchange differences	(5)	2	12	1
Tax effect	1,014	48,755	(1,823)	(3,610)
Other comprehensive income/(loss), net of tax	88,849	(143,548)	23,937	75,900
Total comprehensive (loss)/income for the financial year/period, net of tax	(1,874,444)	870,074	1,117,674	295,207
Attributable to:				
Equity holder of the Bank	(1,874,436)	870,074	1,117,675	295,207
Non-controlling interests	(8)	-	(1)	-
	(1,874,444)	870,074	1,117,674	295,207

4. INFORMATION ON AMBANK (cont'd)**Consolidated statements of financial position**

	←-----As at 31 March-----→			Unaudited as at 30 June 2023 (RM'000)
	2021 (RM'000)	2022 (RM'000)	2023 (RM'000)	
ASSETS				
Cash and short-term funds	9,621,295	9,894,325	6,874,702	5,723,090
Securities purchased under resale agreements	-	-	-	20,905
Deposits and placements with banks and other financial institutions	457,124	2,184,788	1,084,465	2,041,121
Investment account placement	716,091	1,708,484	1,537,252	1,384,544
Derivative financial assets	1,313,003	832,821	923,673	1,513,427
Financial assets at fair value through profit or loss	3,789,592	2,675,904	10,191,801	9,641,269
Financial investments at fair value through other comprehensive income	13,763,607	14,339,584	20,306,352	19,116,286
Financial investments at amortised cost	3,751,441 ⁽ⁱ⁾	5,929,515	9,214,717	8,230,686
Loans and advances	75,512,257 ⁽ⁱ⁾	78,817,487	82,466,414	81,743,154
Statutory deposit with BNM	305,773	200,000	1,552,337	1,630,424
Deferred tax assets	74,858	139,318	164,294	124,374
Investment in associates	31,305	15,597	18,395	-
Other assets	1,569,947 ⁽ⁱ⁾	1,819,943	1,948,382	2,968,324
Right-of-use assets	223,268	172,789	224,596	205,428
Property and equipment	184,473	151,787	146,013	139,878
Intangible assets	254,134	221,538	202,069	202,189
TOTAL ASSETS	<u>111,568,168</u>	<u>119,103,880</u>	<u>136,855,462</u>	<u>134,703,487</u>
LIABILITIES AND EQUITY				
Deposits from customers	79,629,964	85,856,896	85,378,545	85,497,578
Deposits and placements of banks and other financial institutions	7,104,827	7,377,743	8,661,694	9,549,428
Securities sold under repurchase agreements	810,171	1,582,717	16,466,674	13,387,571
Recourse obligation on loans sold to Cagamas Berhad	6,475,018	6,875,023	6,600,036	6,050,029
Derivative financial liabilities	1,273,529	806,634	966,427	1,325,207
Term funding	715,103	1,045,260	1,337,427	1,220,444
Debt capital ⁽ⁱⁱ⁾	2,995,000	3,095,000	3,095,000	3,595,000
Other liabilities	3,802,608	2,382,585	3,149,963	2,747,664
TOTAL LIABILITIES	<u>102,806,220</u>	<u>109,021,858</u>	<u>125,655,766</u>	<u>123,372,921</u>
Share capital	2,590,465	3,040,465	3,040,465	3,040,465
Reserves	6,171,337	7,041,411	8,159,086	8,289,956
Equity attributable to equity holder of the Bank	8,761,802	10,081,876	11,199,551	11,330,421
Non-controlling interests	146	146	145	145
TOTAL EQUITY	<u>8,761,948</u>	<u>10,082,022</u>	<u>11,199,696</u>	<u>11,330,566</u>
TOTAL LIABILITIES AND EQUITY	<u>111,568,168</u>	<u>119,103,880</u>	<u>136,855,462</u>	<u>134,703,487</u>
COMMITMENTS AND CONTINGENCIES	128,117,074	113,360,229	115,723,975	119,437,156
NET ASSETS PER SHARE (RM)	<u>9.70</u>	<u>10.61</u>	<u>11.79</u>	<u>11.93</u>

4. INFORMATION ON AMBANK (cont'd)

Notes:

- i Financial information for 31 March 2021 represents the comparative for audited FYE 31 March 2022.*
- ii Term funding comprises credit linked notes, senior notes and other borrowings.*
- iii Debt capital comprises subordinated notes.*

[The rest of this page has been intentionally left blank]

4. INFORMATION ON AMBANK (cont'd)**Consolidated statements of cash flows**

	←-----FYE 31 March-----→			Unaudited 3-months FPE
	2021 (RM'000)	2022 (RM'000)	2023 (RM'000)	30 June 2023 (RM'000)
CASH FLOWS FROM OPERATING ACTIVITIES				
(Loss)/profit before taxation	(1,800,719)	1,133,446	1,421,369	279,634
Adjustments for:				
Accretion of discount less amortisation of premium	(28,058)	(15,539)	(154,869)	(62,583)
Amortisation of fair value loss on terminated hedge	9,130	8,724	6,320	1,576
Amortisation of intangible assets	80,173	87,034	77,237	17,225
Amortisation of issuance costs and premium for term funding	5,761	3,401	1,166	291
Depreciation of property and equipment	61,423	56,646	49,883	11,869
Depreciation of right-of-use assets	70,244	66,403	73,770	16,948
Finance cost for lease liabilities	8,265	6,642	6,181	1,586
Finance cost for provision for reinstatement for leased properties	133	102	77	15
Gain on disposal of foreclosed properties	(540)	-	-	-
Gain on disposal of property and equipment	(99)	(73)	(8,957)	(7)
Distribution income from financial investments at fair value through other comprehensive income	(8,588)	(8,359)	(8,546)	(4,672)
Impairment loss on financial investments	17,138 ⁽¹⁾	14,279	1,344	12,664
Impairment (writeback)/loss of other financial assets	(569)	1,273	(993)	2,467
Loans and advances - allowances, net of writeback	838,509 ⁽¹⁾	218,509	438,620	171,902
Net adjustment on COVID-19 relief measures	(29,187)	(84,592)	(35,936)	5,920
Net loss/(gain) on revaluation of derivatives	107,537	14,941	68,941	(230,974)
Net (gain)/loss on revaluation of financial assets at fair value through profit or loss	(75,127)	(604)	1,402	85,689
Net gain on sale of financial assets at fair value through profit or loss	(250,240)	(3,172)	(42,316)	(18,049)
Net gain/(loss) on sale of financial investments at fair value through other comprehensive income	(23,492)	(4,218)	(286)	130
Net gain on redemption of financial assets at amortised cost	(3,413)	-	-	-
Remeasurement of right-of-use assets	(6,648)	⁻⁽²⁾	-	-
Remeasurement of lease liabilities	6,726	⁻⁽²⁾	-	-
Remeasurement of provision for reinstatement	6	-	-	-
Gain on termination of lease agreement	-	(54)	(116)	-

4. INFORMATION ON AMBANK (cont'd)**CASH FLOWS FROM OPERATING ACTIVITIES (cont'd.)**

Property and equipment written off	84	39	18	-
Intangible asset written off	-	5	-	-
Reversal of provision for reinstatement cost of leased properties	(1,918)	-	-	-
Share of results of an associate	1,319	708	(2,798)	7
Scheme shares and options granted under AMMB Executives' Share Scheme – charge/(writeback)	29,913	(392)	14,939	1,734
Unrealised foreign exchange (gain)/loss on term funding	(16,935)	6,897	21,125	(25,207)
Provision/(writeback of provision) for commitments and contingencies	47,860	174,204	(85,280)	3,948
Operating (loss)/profit before working capital changes	(961,312)	1,676,250	1,842,295	272,113
(Increase)/decrease in operating assets:				
Deposits and placements with banks and other financial institutions	(77,149)	(899,500)	40,000	(874,592)
Investment account placement	(28)	(992,629)	172,142	151,787
Financial assets at fair value through profit or loss	3,892,598	1,151,846	(7,368,549)	534,969
Loans and advances	(2,810,926) ⁽¹⁾	(3,454,993)	(4,020,835)	562,764
Securities purchased under resale agreements	-	-	-	(20,905)
Statutory deposit with BNM	33,583	105,773	(1,352,337)	(78,087)
Other assets	430,881	(248,429)	(83,902)	(948,865)
Increase/(decrease) in operating liabilities:				
Deposits from customers	821,597	6,226,932	(478,351)	119,033
Deposits and placements of banks and other financial institutions	385,839	304,103	1,248,749	871,370
Securities sold under repurchase agreements	(5,542,538)	772,546	14,883,957	(3,079,103)
Recourse obligation of loans sold to Cagamas Berhad	2,334,995	400,005	(274,987)	(550,007)
Term funding	(740,766)	319,859	269,876	(92,067)
Other liabilities	1,233,944 ⁽²⁾	(1,531,870)	815,340	(360,518)
Cash (used in)/ generated from operating activities	(999,282)⁽¹⁾	3,829,893⁽²⁾	5,693,398	(3,492,108)
Net taxation paid	(228,881)	(135,382)	(414,593)	(96,875)
Net cash (used in)/ generated from operating activities	(1,228,163)⁽¹⁾	3,694,511⁽²⁾	5,278,805	(3,588,983)

4. INFORMATION ON AMBANK (cont'd)**CASH FLOWS FROM INVESTING ACTIVITIES**

Dividend income received from financial investments at fair value through other comprehensive income	8,588	8,359	8,546	4,672
Dividend received from an associate	-	15,000	-	-
Net redemption/(purchase) of financial investments at fair value through other comprehensive income	1,226,702	(806,421)	(5,914,485)	1,254,064
Net (purchase)/sale of financial investments at amortised cost	(723,125) ⁽¹⁾	(2,182,609)	(3,284,695)	980,720
Proceeds from disposal of property and equipment	1,355	352	20,378	7
Purchase of intangible assets	(79,936)	(66,283)	(61,573)	(22,744)
Additions through purchase of property and equipment and transfer from related company	(34,246) ⁽²⁾	(21,051)	(56,029)	(12,415)

Net cash generated from/(used in) investing activities	399,338⁽¹⁾	(3,052,653)⁽²⁾	(9,287,858)	2,204,304
---	------------------------------	----------------------------------	--------------------	------------------

CASH FLOWS FROM FINANCING ACTIVITIES

Dividends paid	(132,223)	-	-	(164,337)
Issuance of share capital	650,000	450,000	-	-
Payment of lease liabilities	(76,618)	(73,648)	(77,068)	(17,881)
Net proceeds from issuance of Subordinated Notes	400,000	100,000	-	500,000

Net cash generated from/(used in) financing activities	841,159	476,352	(77,068)	317,782
---	----------------	----------------	-----------------	----------------

Net increase/(decrease) in cash and cash equivalents	12,334	1,118,210	(4,086,121)	(1,066,897)
---	---------------	------------------	--------------------	--------------------

CASH AND CASH EQUIVALENTS AT BEGINNING OF THE FINANCIAL YEAR/PERIOD

Effect of exchange rate changes	190	(555)	146	276
---------------------------------	-----	-------	-----	-----

CASH AND CASH EQUIVALENTS AT END OF THE FINANCIAL YEAR/PERIOD

	10,021,441	11,139,096	7,053,121	5,986,500
--	-------------------	-------------------	------------------	------------------

[The rest of this page has been intentionally left blank]

4. INFORMATION ON AMBANK (cont'd)

	←-----FYE 31 March----->			Unaudited 3-months FPE 30 June 2023 (RM'000)
	2021 (RM'000)	2022 (RM'000)	2023 (RM'000)	
Cash and cash equivalents comprise:				
Cash and short-term funds	9,621,295	9,894,325	6,874,702	5,723,090
Deposits and placements with banks and other financial institutions	457,124	2,184,788	1,084,465	2,041,121
	10,078,419	12,079,113	7,959,167	7,764,211
Less: Deposits with original maturity more than 3 months	(59,276)	(943,435)	(907,860)	(1,781,489)
	10,019,143	11,135,678	7,051,307	5,982,722
Add back:				
Allowances for expected credit loss ("ECL") for cash and cash equivalents at end of the financial year/period	2,298	3,418	1,814	3,778
	10,021,441	11,139,096	7,053,121	5,986,500

Notes:-

1. Financial information for 31 March 2021 represents the comparative for audited FYE 31 March 2022.
2. Financial information for 31 March 2022 represents the comparative for audited FYE 31 March 2023.

Please refer to our website at www.ambankgroup.com for detailed information on our audited financial statements, or any subsequent updates thereto.

4.9 Risk Management

Group Risk Management Division is independent of the various business units and acts as the catalyst for the development and maintenance of comprehensive and sound risk management policies, strategies and procedures within our Group wherein the Board plays a vital role in approving policies set for the Group. Group Risk Management Division comprises Wholesale Credit Risk ("WCR"), Business Credit Risk, Retail Credit Risk, Investment Banking and Markets Risk ("IBMR"), Group Operational Risk, Group Technology Risk, Portfolio Risk Management (which is responsible for the development of credit models), Credit Model Validation and Independent Credit Review departments.

The risk management functions take its lead from the Board's Approved Risk Appetite Framework that forms the foundation of our Group to set its risk/reward profile. The framework is reviewed and approved annually by our Board taking into account our Group's desired external rating and targeted profitability/return on capital employed and is reviewed periodically throughout the financial year by both our key management team (as stated in Section 4.5 of this Base Prospectus) and our Board to consider any fine tuning/enhancements taking into account prevailing or expected changes to the environment that our Group operates in.

4.9.1 Risk Management Governance

Our Board is ultimately responsible for the management of risks within our Group. Our RMC comprises three (3) members, all of whom are Non-Executive Directors and is chaired by an Independent Non-Executive Director. RMC is formed to assist our Board in discharging its duties

4. INFORMATION ON AMBANK (cont'd)

in overseeing the overall management of credit, market, liquidity, operational, technology and cyber security, legal, capital, regulatory compliance, shariah and reputational risks impacting the Group.

Our Board has also established management risk committees such as Group Management Risk Committee (“**GMRC**”) and Group Assets and Liabilities Committee (“**GALCO**”) to assist it in managing risks and compliance matters of our Group. These committees address all classes of risk within its Board delegated mandate: balance sheet risk, credit risk, legal risk, operational risk, market risk, Shariah risk, compliance risk, reputational risk, sustainability (covering environmental, social and governance (ESG), climate change, business and technology and cyber security risk.

GMRC comprises the following permanent members:

- Group Chief Executive Officer (the chairman)
- Group Chief Risk Officer (the alternate chairman)
- Group Chief Financial Officer
- Group Chief Operations Officer
- AmBank Chief Executive Officer
- AmBank Islamic Berhad Chief Executive Officer
- AmInvestment Bank Chief Executive Officer
- Managing Directors – line of business

GALCO comprises the following permanent members:

- Group Chief Executive Officer (the chairman)
- Group Chief Financial Officer (the alternate chairman)
- Group Chief Risk Officer
- AmBank Chief Executive Officer
- AmBank Islamic Berhad Chief Executive Officer
- AmInvestment Bank Chief Executive Officer
- Managing Directors – line of business
- Head of Group Treasury & Markets of AmBank Group

The Group’s risk management function is independent of the Group’s business and is headed by the Group Chief Risk Officer who reports directly to the Board. The Group Chief Risk Officer, through the RMC:

- is responsible for establishing an enterprise wide risk management framework in all areas including financial, credit, market, operational, reputational, security, technological and emerging risks; and
- essentially champions and embeds a positive risk culture across the Group to ensure that risk taking activities across the Group are aligned to the Group’s risk appetite and strategies.

Material issues of concern across the organization are escalated to the Board and the boards of the respective banking entities by the Group Chief Risk Officer.

4.9.2 Risk Management Approach

The risk management approach sets out the policies, techniques, tools and responsibilities for effective management.

(i) Business Risk

Business risk is the risk of loss arising from the inability to adapt cost structures, products, pricing, or activities in response to lower than expected revenues, or higher than expected costs (excluding risks elsewhere defined), caused by an unexpected adverse change in the economy and general business conditions / operating environment. Progress of the Group’s business plans and performance achievements are rigorously tracked and reviewed against budget in monthly review meetings and specific taskforce set up for the purposes of monitoring our key focus areas allowing for timely responses and corrective actions to be taken to mitigate business risk.

4. INFORMATION ON AMBANK (cont'd)

(ii) Capital Risk

Capital risk could arise from the depletion of capital buffers that is essential to support a financial institution's risk profile and the minimum capital requirements prescribed by BNM. Maintaining adequate amount of capital buffers is essential to ensure the continuing ability of our Group to meet our obligations as they fall due which include the obligation in respect to our Structured Warrants.

The capital adequacy of AmBank is managed both at the entity and consolidated level. Our Group's capital management approach is focused on maintaining an optimal capital position that supports the Group's strategic objectives and risk appetite. The Group's capital management is guided by the Group Capital Management Framework.

In line with the Group's annual three (3) year strategy plan, a capital plan is developed and approved by Board to ensure that adequate level of capital and an optimum capital structure is maintained to meet regulatory requirements by our Group strategic objectives and stakeholders' expectations.

The Group uses internal models and other quantitative techniques in its internal risk and capital assessment to enable our Group to gain a deeper understanding of its risk profile. Stress testing is used to ensure that the Group's internal capital assessment considers the impact of extreme but probable scenarios on its risk profile and capital position. They provide an insight into the potential impact of significant adverse events on the Group and how these events could be mitigated. Our Group's target capital levels are set taking into account its risk appetite and its risk profile under future expected and stressed economic scenarios.

The Group has in place processes and controls to monitor and manage capital adequacy. Our GALCO is responsible for overseeing and managing the Group's capital and liquidity positions.

A strong governance and process framework is embedded in the capital planning and assessment methodology. Overall responsibility for the effective management of risk rests with our Board. Our RMC is specifically delegated the task of reviewing all risk management issues including oversight of our Group's capital position and any actions impacting the capital levels.

(iii) Market Risk

Market risk is the risk of losses due to adverse changes in the level or volatility of market rates or prices, such as interest rates, credit spreads, equity prices and foreign exchange rates. The Bank differentiates between two categories of market risk: Traded Market Risk ("TMR") and Non-Traded Market Risk ("NTMR"). Assessment, control and monitoring of these risks are the responsibilities of IBMR.

[The rest of this page has been intentionally left blank]

4. INFORMATION ON AMBANK (cont'd)

Traded Market Risk

Our TMR management process is depicted in the table below.

Identification	<ul style="list-style-type: none"> Identify market risks within existing and new products Review market-related information such as market trends and economic data
Assessment/ Measurement	<ul style="list-style-type: none"> Value-at-Risk ("VaR") Loss Limits Historical Stress Loss ("HSL") Present Value of One Basis Point ("PV01") Sensitivity to change Other Detailed Controls
Control/ Mitigation	<ul style="list-style-type: none"> VaR Limits Loss Limits / Triggers (Annual/ Monthly/ Daily) HSL Limits PV01 Limits Greek Limits (Delta-Gamma/ Vega/ Theta) Concentration Limits Position Size Limits Maximum Tenor Limits Maximum Holding Period Minimum Holding Period Approved Portfolio Products Approved Countries/ Currencies Other Detailed Limits/Triggers
Monitoring/ Review	<ul style="list-style-type: none"> Monitor controls Periodical review and reporting

TMR arises from transactions in which the Bank acts as principal with clients or the market which include the issuance of Structured Warrants as well as other positions taking in fixed income, equity, foreign exchange, commodities and/ or derivatives by the Bank. TMR is managed via robust traded market risk measurement, limit setting, and limit monitoring.

VaR, Loss Limits, HSL and other detailed management controls are used to measure, monitor and control TMR exposures:-

- VaR is a quantitative measure which the Bank applies recent historical market conditions to estimate potential losses in market value, at a certain confidence level and over a specified time horizon (i.e. holding period). VaR is calculated daily by revaluing the financial instruments on the market rates generated based on actual historical movements. It will be monitored against the VaR limits approved by our Board/Management and VaR reports are disseminated to business units on a daily basis. Any breach of limit will be escalated as per our Market Risk exception management procedures.
- Loss limits serve to alert management on the need to take relevant and appropriate action once they are triggered.
- HSL is used as a measure of the potential impact on portfolio values due to more extreme, albeit plausible, market movements. In addition, HSL is used to gauge and ensure that the Bank is able to absorb extreme, unanticipated market movements.
- Sensitivity controls (e.g. Greek Limits / PV01 Limits) and indicators are used to monitor changes in portfolio value due to changes in risk factors under different market conditions.

4. INFORMATION ON AMBANK (cont'd)

IBMR independently monitors portfolio market risk exposures against limits on a daily basis and report to GMRC, RMC and the Board. Policies and procedures are in place to ensure prompt action is taken in the event of non-adherence to limits.

Non-Traded Market Risk

NTMR refers to interest rate risk in the banking book (“**IRRBB**”) including those arising from balance sheet management activities primarily comprising of securities, loans, deposits and long term borrowings classified as amortised cost. IRRBB is the risk arising from adverse changes in market interest rates that impact the Bank’s core net interest income, future cash flows or fair values of financial instruments. IRRBB is managed to minimise potential risk to our capital base and future earnings which may impact our ability to meet the obligation arising from the issuance of Structured Warrants.

The IRRBB risk management process is depicted in the table below:-

Identification	<ul style="list-style-type: none"> Identify IRRBB within existing and new products. Review market-related information such as market trend and economic data
Assessment/ Measurement	<ul style="list-style-type: none"> PV01 Earnings-at-Risk (“EaR”) ICAAP IRRBB Economic Value of Equity (“EVE”) ICAAP IRRBB EaR
Control/ Mitigation	<ul style="list-style-type: none"> PV01 Triggers EaR Triggers ICAAP IRRBB EVE / Total Capital Trigger ICAAP IRRBB EaR / Total Net Interest Income Trigger
Monitoring/ Review	<ul style="list-style-type: none"> Monitor controls Periodical review and reporting

IRRBB arises from mismatches between repricing dates of assets and liabilities, changes in yield curves, volatilities in interest margins and implied volatilities on interest rate options. The provision of retail and wholesale banking products and services (primarily lending and deposit taking activities) creates interest rate-sensitive positions in the Bank’s statement of financial position.

Our Board’s oversight of IRRBB is supported by GALCO and GMRC. The Board and GMRC are responsible for the alignment of Bank-wide risk appetite. GALCO reviews strategies to ensure a comfortable level of IRRBB is maintained taking into consideration the Bank’s business strategies. GALCO is also responsible for overseeing the Bank’s non-traded interest / profit rate risk exposures, asset growth and liability mix against the interest rate outlook. IRRBB exposures are monitored by IBMR and these exposures are reported to GALCO, GMRC, RMC and our Board.

The Bank has successfully engaged long-term borrowings and written interest rate swaps to manage IRRBB and maintained an acceptable interest rate risk profile as a result. In accordance with the Bank’s policy, IRRBB positions are monitored on a monthly basis and hedging strategies are employed to ensure risk exposures are maintained within management-established limits.

The Bank measures the IRRBB exposures using PV01, a quantitative measure to assess the impact of change due to movement in market interest rates. The Bank complements PV01 by stress testing IRRBB exposures to highlight potential risk that may arise from extreme market events that are rare but plausible.

The Bank’s strategy seeks to optimise exposure to IRRBB within management-approved limits. This is achieved through the ability to reposition the interest rate exposure of the

4. INFORMATION ON AMBANK (cont'd)

statement of financial position using various product and funding strategies, supported by interest rate hedging activities using interest rate swaps and other derivatives. These approaches are governed by the Bank's policies in the areas of product and liquidity management as well as the Trading Book and Banking Book Policy, hedging policies and Non-Traded Interest Rate Risk Framework.

(iv) Liquidity Risk and Funding Management

Liquidity risk is the risk that the organization either does not have sufficient financial resources available to meet all its obligations and commitments as they fall due, or can only access these financial resources at an unreasonable cost. Liquidity risk exposure arises mainly from the deposit taking and borrowing activities and market disruption, and to a lesser extent, significant drawdown of funds from previously contracted financing and purchase commitments. Funding management is the ongoing ability to raise sufficient funds to finance actual and proposed business activities at a reasonable cost. Improper funding management may lead to liquidity problem. On the other hand, insufficient liquidity risk management may also give rise to funding risk.

The liquidity risk management process is depicted in the table below:-

Identification	<ul style="list-style-type: none"> Identify liquidity risk within existing and new business activities Review market-related information such as market trend and economic data Keep abreast with regulatory requirements
Assessment/ Measurement	<ul style="list-style-type: none"> Liquidity Coverage Ratio (“LCR”) Net Stable Funding Ratio (“NSFR”) Depositor Concentration Ratios Other Detailed Controls
Control/ Mitigation	<ul style="list-style-type: none"> LCR Limits NSFR Limits/Targets Depositor Concentration Ratios Other Detailed Triggers/Targets
Monitoring/ Review	<ul style="list-style-type: none"> Monitor controls Periodical review and reporting

The liquidity risk management of the Bank is aligned with the LCR policy document and NSFR policy document issued by BNM. The primary objective of the Bank's liquidity risk management is to ensure the availability of sufficient funds at a reasonable cost to honour all financial commitments when they fall due. This objective is partly managed through maintenance of a portfolio of high-quality liquid assets to protect against adverse funding conditions and support day-to-day operations. The secondary objective is to ensure an optimal funding structure and to balance the key liquidity risk management objectives, which includes diversification of funding sources, customer base and maturity period.

The Board provides the liquidity risk management oversight including setting and reviewing the liquidity risk appetite and approves the Bank's liquidity management strategy while GALCO is the core management committee established by the Board to oversee the overall liquidity management of the Bank.

The Bank has put in place a Contingency Funding Plan to identify early warning signals of possible liquidity problem. The Contingency Funding Plan also sets out the detailed responsibilities among the relevant departments in the event of actual liquidity crises occurring to ensure orderly execution of procedures to restore the liquidity position and confidence in the organisation.

4. INFORMATION ON AMBANK (cont'd)

Various liquidity measurements have been put in place to support the broader strategic objectives of the Bank and amongst others include the BNM LCR, BNM NSFR, Depositor Concentration Ratio and other Liquidity Ratios.

Stress testing is undertaken to assess and plan for the impact for various scenarios which may put the Bank's liquidity at risk. The Bank further stresses the importance of the stable funding sources to finance placement and loans to customers.

(v) Credit Risk

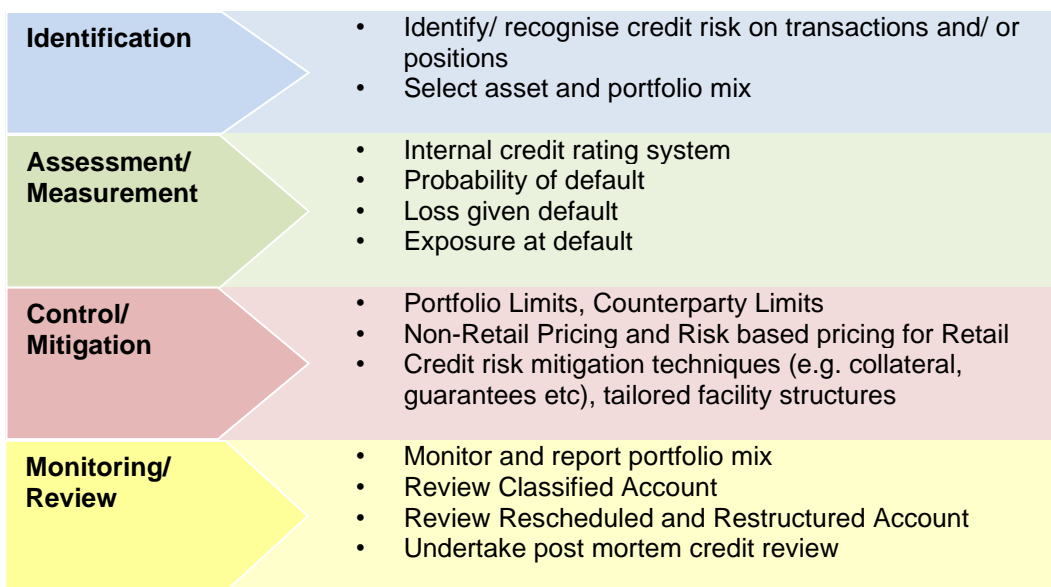

Credit risk is the risk of loss due to the inability or unwillingness of a counterparty to meet its payment obligations. Exposure to credit risk arises from lending, securities and derivative exposures. Credit risk management is important to ensure long-term sustainability of our Bank and our ability to meet the obligation arising from the issuance of Structured Warrants.

The primary objective of credit risk management is to ensure that credit risk exposure is in line with the risk appetite that the Bank is able and willing to accept in pursuit of its strategic and business objectives and related credit policies. Such credit policies provide the minimum standards for comprehensive credit risk taking activities i.e. identification, assessment, approval, measurement, monitoring and mitigation of credit risks and are subjected to periodic reviews to reflect prevailing business conditions in the Bank's market segment i.e. Wholesale Banking, Business Banking and Retail Banking.

For non-retail credits (e.g. Wholesale Banking and Business Banking exposures), risk assessment is a combination of both quantitative and qualitative assessment (including the financial standing of the customer or counterparty using the Bank's credit model where the scores are translated into rating grade) on the customer or counterparty. The assigned credit rating grade forms a crucial part of the credit analysis undertaken for each of the Bank's credit exposures and the overall credit assessment is conducted either through a program lending or discretionary lending approach.

For retail credits (e.g. financing applications under hire purchase, credit card, mortgages, retail small medium enterprise banking, Amanah Saham Bumiputera and etc.), credit checking and decision automation via credit-scoring systems to better differentiate the quality of borrowers are being used to enhance the credit assessment, approval processes and deviation management.

We conduct credit reviews to closely monitor the credits granted and allows for early detections of any adverse changes to the likelihood of default or if an obligor is unable/unlikely to meets its payment obligations, whilst internal audit conducts

4. INFORMATION ON AMBANK (cont'd)

independent assessment on the effectiveness and adequacy of the credit risk management practices and processes of the Bank.

Individual credit risk exposure exceeding certain thresholds is escalated to higher approving authority or Credit and Commitments Committee (“**CACC**”) for approval. In the event such exposure exceeds certain thresholds in aggregate to the counterparty in AmBank Group, it will be submitted to Board Credit Committee (“**BCC**”) for review with the powers to veto or reject the credit facilities and commitments, or modify the terms and conditions, as the case may be.

BCC comprises three (3) members, all of whom are Non-Executive Directors.

CACC comprises the following permanent members:

- Group Chief Executive Officer (the chairman)
- Group Chief Risk Officer (the alternate chairman; or in his absence, Head of WCR)
- AmBank Chief Executive Officer
- AmBank Islamic Berhad Chief Executive Officer
- AmInvestment Bank Chief Executive Officer
- Managing Directors – line of business

Our GMRC meets at least six (6) times a year to review the quality and diversification of our Group’s loan/ financing portfolio and review the portfolio risk profile against our Group’s risk appetite and recommend or approve new and amended credit risk policy and guideline.

Group Risk Management Division prepares monthly risk reports which detail important portfolio composition and trend analysis incorporating asset growth, asset quality, impairments, flow rates of loan/ financing delinquency buckets and exposures by industry sectors. These information are reported to our key management team (as stated in Section 4.5 of this Base Prospectus), RMC and Board.

(vi) Operational Risk

The operational risk management process is depicted in the table below:-

Identification	<ul style="list-style-type: none"> • Identify and analyse risks in key processes/ activities within Business Lines (as defined in Basel II) (including new products)
Assessment/ Measurement	<ul style="list-style-type: none"> • Incident Management and Data Collection • Risk and Control Self Assessment • Key Risk Indicators • Key Control Testing • Scenario analysis • Periodic review of control testing
Control/ Mitigation	<ul style="list-style-type: none"> • Policies addressing control & governance requirements to mitigate specific operational risk • Advisory on the establishment of internal controls • Contingency planning
Monitoring/ Review	<ul style="list-style-type: none"> • Monitoring and reporting of loss incidents by Event Type, Portfolio and Business Lines (as defined in Basel II) and entity, reporting of operational risk board and management triggers, risk profile status, key risk indicator breaches and key control testing exceptions. • Periodical review of risk profile within Business Lines (as defined in Basel II)

Operational risk is defined as risk of loss resulting from inadequate or failed internal processes, people and systems or from external events which includes but is not limited to legal risk, outsourcing risk, technology (including cyber) risk and Shariah non-compliance risk. Operational risk is inherent in all the Group’s divisions including the

4. INFORMATION ON AMBANK (cont'd)

structured warrant business, which may result in direct or indirect financial and non-financial impact to the Group.

Operational Risk Appetite (“**ORA**”) is set as part of overall Group Risk Appetite Framework (“**GRAF**”), which is approved by the Board and sets the acceptable tolerance levels of operational risk that the Group is willing to accept, taking into consideration of the relevant financial and non-financial risks or return attributes in order to support the achievement of the Group’s strategic plan and business objectives. The ORA statements and measurements are classified based on operational loss event types, which are grouped into five (5) categories as below and monitored via Incident Management and Data Collection, Key Risk Indicator (“**KRI**”) and Key Control Testing (“**KCT**”):

- Fraud (Internal and External);
- Employment Practices and Workplace Safety;
- Client, Products and Business Practices;
- Business Disruption, System Failures and Damage to Physical Assets; and
- Execution, Delivery and Process Management.

The strategy for managing operational risk in our Group is anchored on the three lines of defence concept which are as follows:

- The first line of defence is responsible for the management of operational risk in ensuring that accountability and ownership is as close as possible to the activity that creates the risk and ensuring that effective action is taken to manage them. First line of defence provides a business specific focus on the implementation of operational risk management activities and supports more effective day-to-day monitoring of operational risks.
- In the second line, Group Operational Risk is responsible for exercising governance over operational risk through the management of the operational risk framework, guideline development and communication, quality assurance of internal controls, challenging the periodical review or updating of the risk identification and measurement process / KRIs / KCTs of all line of business, conducting operational risk management training, timely reporting of significant operational risk incidents including KCT, KRI breaches and risk mitigation measures and strategies to GMRC, RMC and the Board.
- Group Internal Audit acts as the third line of defence by providing independent assurance on the internal control effectiveness through periodic audit programme.

Group Operational Risk works closely with all lines of business to identify operational risks inherent in their respective business activities, assessing the impact and significance of these risks and ensuring that satisfactory risk mitigation measures and controls are in place. Various tools and methods are employed to identify, measure, control and monitor/ report operational risk issues within the Group.

In terms of risk transfer strategy, our Group obtains third party insurance to cover major operational risks where cost-effective premiums can be obtained. In addition, a comprehensive Business Continuity Management is established to ensure critical business functions can be maintained or restored in a timely manner, in the event of material disruptions from internal or external events.

(vii) Technology and Cyber Security Risk

Technology and Cyber Security risk refers to any risk of financial loss, disruption or damage to the reputation of an organisation as a result of the failure of its information technology systems. Our Group’s operations including the structured warrants business operation are highly dependent on the continued employment of information technology systems. Any breakdown or system failure could have a major impact on our businesses.

4. INFORMATION ON AMBANK (cont'd)

The Group's Technology Risk Management Framework and Cyber Resilience Policy provide the guiding principles to the Group's management of technology risks, as well as the resilience of the Group's IT infrastructure and cyber security capabilities, especially with regards to safeguarding customers' information and critical technology assets.

Regular reporting into the GMRC that meets a minimum of six (6) times per year, and subsequently, the RMC and Board is made to ensure that senior management and members of the Board are kept apprised of technology and cyber risks.

Driven by the constantly evolving nature and sophistication of cyber threats and attack vectors, the Group aims to identify threats in a timely manner and build or enhance the right defenses to mitigate risks. The Group continues to enhance cyber security capabilities, execute internal assessment reviews, provide oversight over defense mechanisms and uplift governance processes alongside the Group's cyber risk management strategy. Creating a security mindset for employees and customers via its cyber security awareness programs also remains a priority.

(viii) Legal Risk

In all the jurisdictions that our Group conducts its business, it is subject to legal risks arising from potential breaches of applicable laws, unenforceability of contracts, lawsuits, or adverse judgement, which may lead to incurrence of losses, disruption or otherwise impact on our Group's financials or reputation.

Legal risk is overseen by GMRC, upon advice by internal legal counsel and, where necessary, in consultation with external legal counsel to ensure that such risks are appropriately managed.

(ix) Regulatory Compliance Risk

The Group has in place a compliance framework to promote the safety and soundness of the Group by minimising financial, reputational and operational risks arising from non-compliance with laws, rules, standards and regulatory requirements issued by regulators relevant to the Bank's activities.

The Group believes in a strong compliance culture where the Board and senior management lead by example. The Group continues to exercise and enhance its due diligence governance process and remains sensitive towards emerging risk, regulatory surveillance and enforcement.

Our compliance framework describes the various roles and responsibilities involved in compliance with regulatory guidelines and requirements, allowing all employees to understand their roles in managing compliance risk. The Board oversees the management of compliance risk and the senior management is collectively responsible for effective management of compliance risk to promote the safety and security of the Group's processes and increasing awareness on the role of every employee to safeguard the Group.

(x) Reputational Risk

Reputational risk is the risk that a company will lose current and future business because its character or quality has been called into question and/or incur substantial financial penalties arising from the failure to comply with relevant laws and regulations.

Our Group recognises that maintaining its reputation among clients, investors, regulators and the general public is an important aspect of minimising legal and operational risk. Maintaining the reputation depends on a large number of factors, including the selection of our clients and business partners and the conduct of our business activities.

4. INFORMATION ON AMBANK (cont'd)

Our Group seeks to maintain its reputation by screening potential clients and business partners and by conducting our business activities in accordance with regulatory requirements.

Please also refer to Section 6.1.10 of this Base Prospectus on the reputational risk relating to us.

4.10 Audit and Examination Committee

As at the LPD, the Audit and Examination Committee (“AEC”) comprises the following members:

Name	Designation	Directorship
Dr Veerinderjeet Singh a/l Tejwant Singh	Chairman	Independent Non-Executive Director
U Chen Hock	Member	Independent Non-Executive Director
Foong Pik Yee	Member	Independent Non-Executive Director

Our Board established the AEC to assist Board ensuring there is independent oversight of the Bank’s financial reporting and internal control systems that facilitates appropriate checks and balances within the bank.

The AEC’s main functions and duties shall include, but are not limited to the following:

- oversight of matters related to financial reporting and internal controls;
- oversight of matters related to internal and external audit;
- direct and supervise special audits and investigations;
- review and recommend for Board’s approval, related party transactions and conflict of interest situations that may arise within the Bank;
- reporting to the Board on audit reports and key issues deliberated at AEC meetings;
- advise the Board on any major audit and/or tax related issues; and
- oversight of whistleblowing cases of the Bank via the investigation report.

4.11 Hedging Strategy for Structured Warrants

Our Group enters into a variety of equity derivatives transactions including issuance of structured warrants. The same categories of risk exposure resulting from our Group’s transactions are consolidated and managed as a portfolio. Any residual risk exposure under the portfolio that cannot be fully eliminated may be hedged by entering into an exposure including but not limited to the Underlying Instruments, options, futures contracts, swaps or other derivatives instruments that produces the opposite value movements to the residual risk. We may enter into over-the-counter derivatives transactions with another financial institution counterparty to hedge the portfolio residual risks. Our Group has in place policies and procedures to govern the selection of counterparty and managing counterparty credit risks.

[The rest of this page has been intentionally left blank]

4. INFORMATION ON AMBANK (cont'd)**4.12 Previous Experience with Structured Warrants**

AmInvestment Bank was initially the issuer for Structured Warrants from 2006 to 2009. Pursuant to an internal group restructuring of the AMMB Group, the Structured Warrants business was then undertaken by AmBank since 2010.

As at LPD, AmInvestment Bank and AmBank, have in aggregated issued a total of 1,275 series of call warrants and put warrants.

A summary of issuance of Structured Warrants by AmInvestment Bank since 2006 are set out as follows:-

Base Prospectus Date	Type	Exercise Style	Settlement Type	Number of structured warrants listed
30 June 2006	Call Warrants	American	Cash	5
30 April 2008	Call Warrants	American	Cash	2
	Call Warrants	European	Cash	1
6 August 2009	Call Warrants	European	Cash	15
	Put Warrants	European	Cash	1
TOTAL				24

A summary of issuance of Structured Warrants by AmBank since 2010 are set out as follows:-

Base Prospectus Date	Type	Exercise Style	Settlement Type	Number of structured warrants listed
23 August 2010	Call Warrants	European	Cash	80
	Put Warrants	European	Cash	8
23 August 2011	Call Warrants	European	Cash	87
	Put Warrants	European	Cash	11
23 August 2012	Call Warrants	European	Cash	89
	Put Warrants	European	Cash	6
23 August 2013	Call Warrants	European	Cash	56
9 September 2014	Call Warrants	European	Cash	59
1 December 2016	Call Warrants	European	Cash	103
6 July 2018	Call Warrants	European	Cash	94
17 July 2019	Call Warrants	European	Cash	159
13 August 2020	Call Warrants	European	Cash	156
24 August 2021	Call Warrants	European	Cash	213
29 August 2022 (up to LPD)	Call Warrants	European	Cash	125
	Put Warrants	European	Cash	5
TOTAL				1,251

[The rest of this page has been intentionally left blank]

5. PARTICULARS OF THE OFFER

5.1 The Offer

We propose to issue the following non-collateralised structured warrants:-

- (i) American or European style cash-settled call or put warrants over a single equity;
- (ii) American or European style cash-settled call or put warrants over a basket of equities;
- (iii) American or European style physical-settled call warrants over a single equity;
- (iv) American or European style cash-settled call or put warrants over a single index;
- (v) American or European style cash-settled call or put warrants over a single ETF;
- (vi) American or European style physical-settled call warrants over a single ETF; and/or
- (vii) Bull ELS,

where the Underlying Equities and ETFS are listed on, and indices are based on Bursa Securities and/or Securities Exchanges outside Malaysia which are members of the World Federation of Exchanges or are approved by Bursa Securities.

The Structured Warrants will be offered from time to time by way of placement to selected investors or by way of Market Making.

We will issue the Structured Warrants from time to time through this Base Prospectus supported by a Term Sheet to be issued before we issue each series of the Structured Warrants.

Each Offer of a series of Structured Warrants will be for a minimum aggregate face amount of RM5 million as required by the Listing Requirements.

The issuance of Structured Warrants on the Underlying Companies, Underlying Equities, Underlying ETFs and Underlying Indices do not represent our recommendation. We take no responsibility, and accept no liability for, and make no representation or warranty (whether express or implied) of the Underlying Companies, Underlying Equities, Underlying ETFs or Underlying Indices in relation to the Offer.

Further information on the Offer and the Structured Warrants are set out below and in Annexure I of this Base Prospectus respectively.

5.2 Market Making

The Listing Requirements provides that upon initial listing, there must be at least one hundred (100) Holders holding not less than one (1) board lot of warrants each, or at least fifty (50) Holders subscribing for a minimum of RM100,000 of warrants each ("**Minimum Holders Requirement**"), unless the issuer provides liquidity for the Structured Warrants via Market Making. 1 board lot comprises 100 Structured Warrants or such other number of Structured Warrants as permitted by the SC and/or Bursa Securities.

We are a registered Market Maker pursuant to the Rules of Bursa Securities and will be acting as the Market Maker for our Structured Warrants on Bursa Securities by providing bid and offer quotes in the trading system of Bursa Securities on each Market Day, over the tenure of our Structured Warrants. Therefore, we are not required to fulfil the Minimum Holders Requirement mentioned above.

[The rest of this page has been intentionally left blank]

5. PARTICULARS OF THE OFFER (*cont'd*)

As a Market Maker we are required to comply with the Rules of Bursa Securities pertaining to minimum presence of Market Making, maximum bid-offer spread and minimum quantity for each quotation, as may be amended from time to time, and are currently prescribed under the relevant circulars to the Rules of Bursa Securities as follows:-

- (i) The minimum presence on each day that Bursa Securities is open for trading in the Structured Warrants : 80% of trading hours
- (ii) The maximum spread of two-sided Market Making quotes : Ten (10) bids
- (iii) The minimum quantity on each of the two-sided Market Making quotes : Fifty (50) Board Lots (5,000 units of Structured Warrants)

You may refer to https://www.bursamalaysia.com/trade/trading_resources/equities/board_lot for information on "minimum bid". Please note, however, the information contained in this website does not form part of this Base Prospectus.

You should note that there will be circumstances when we may not be able to and will not be obliged to provide bid and offer quotes, or respond to a request for quotes. Such circumstances may include, without limitation, the occurrence or existence of one (1) or more of the following events:-

- (i) when our Structured Warrants are suspended from trading or limited in a material way for any reason;
- (ii) if, in our sole and absolute discretion, determines that, the theoretical bid / offer price of our Structured Warrants is less than the minimum price or greater than the maximum price that can be entered into the automated and computerised securities trading system established by Bursa Securities through which we enter orders for our Structured Warrants for the purpose of providing liquidity;
- (iii) when we experience technical difficulties or when operational and technical problems affect the proper functions of Bursa Securities;
- (iv) when our ability to source a hedge or unwind an existing hedge, as we determine in good faith, is materially affected by the prevailing market conditions;
- (v) when any other circumstances outside our reasonable control make it impossible or impractical for us to continue to provide liquidity for our Structured Warrants;
- (vi) during pre-market opening, five (5) minutes following the opening of Bursa Securities and the last fifteen (15) minutes prior to the close of a trading session on any trading day;
- (vii) when trading in:-
 - (a) the Underlying Instrument,
 - (b) option contracts or futures contracts relating to the Underlying Instrument, or
 - (c) the compilation and publishing of the Underlying Index,
 are suspended or limited in a material way for any reason; for the avoidance of doubt, we are not obliged to provide quotation for our Structured Warrants at any time when the Underlying Instrument, or relevant option contract or future contract are not traded or the Underlying Index is not compiled or published for any reason;
- (viii) when the stock market experiences exceptional price movements and volatility;
- (ix) when it is a public holiday in Malaysia and Bursa Securities is not open for trading;
- (x) when the relevant Securities Exchange on which the Underlying Instruments or option contract and futures contracts relating to the Underlying Instrument are quoted and traded on the relevant Securities Exchange and/or where the Underlying Index is compiled and published is not open for trading;

5. PARTICULARS OF THE OFFER *(cont'd)*

- (xi) market disruption events such as any suspension of or limitation imposed on trading (by reason of movements in price exceeding limits permitted by the relevant Securities Exchanges or otherwise) and any event that disrupts or impairs our ability to effect transactions in relation to the:-
 - (a) Underlying Instrument,
 - (b) option contracts or futures contracts relating to the Underlying Instrument, and/or
 - (c) any Structured Warrants;
- (xii) when each of our Structured Warrants is theoretically valueless (where the bid price is below RM0.005); In such an instance, we will provide the offer price only;
- (xiii) when the number of Structured Warrants available for Market Making by us is less than 5% of the total issue size of the Structured Warrants, for the avoidance of doubt, in determining whether the Structured Warrants are available for Market Making, Structured Warrants held by us or any of our affiliates in a fiduciary or agency (as opposed to proprietary) capacity shall be deemed not available for Market Making;
- (xiv) during the suspension period immediately prior to the expiry date of the Structured Warrants as determined by Bursa Securities; or
- (xv) the case of an Underlying Index, any modification, cancellation or disruption of the calculation of the Underlying Index (other than as a result of a market disruption event);
- (xvi) in the case of put warrants, our ability to perform short-selling in the market becomes restricted or prohibited; or
- (xvii) in any circumstances as may be determined by Bursa Securities and/or the SC from time to time.

Although we may facilitate liquidity provision activities to provide liquidity for our Structured Warrants on Bursa Securities, the level of liquidity will depend on competitive forces and the price at which our Structured Warrants trade on Bursa Securities upon or subsequent to its Listing.

You may obtain bid/offer prices for the Structured Warrants (in respect of prices that appear on the trading system of Bursa Securities, and/or in respect of direct business transactions) from us at the following contact details:

AmBank (M) Berhad
 Group Treasury & Markets, Equity Derivatives
 Telephone no: (+603) 2059 8698

5.3 Further Issue

The Deed Poll allows us to create and issue further Structured Warrants in respect of the same series of Structured Warrants ("**Further Issue**") without the consent or sanction of the existing Holders of the Structured Warrants, pursuant to this Base Prospectus. The Further Issue will form part of the existing Structured Warrants in issue ("**Existing Issue**").

For the purpose of facilitating Market Making, we may apply for Further Issue in respect of the Structured Warrants, subject to the following conditions:-

- (i) the Further Issue is for the purpose of facilitating Market Making;
- (ii) the terms and conditions of the Existing Issue either permit the Further Issue or have been properly amended to give us the right to create, issue and list one or more Further Issues;
- (iii) the terms and conditions of the Further Issue and the Existing Issue must be identical except for the size and tenure of the issue; and
- (iv) we hold not more than 50% of the Existing Issue at the time of application for the Further Issue.

5. PARTICULARS OF THE OFFER (*cont'd*)

5.4 Purposes of the Offer

The Offer is in line with our objective to actively participate and contribute to the development, promotion and growth of Structured Warrants in the Malaysian capital market. Structured Warrants could provide investors diversification benefits and potentially enhance returns of the investors' portfolio. Save for Bull ELS, Structured Warrants offer some degree of leverage or gearing, where a small percentage change in the price / level of the Underlying Instruments may result in larger percentage change in the price of the Structured Warrants.

The Offer also enables us to earn revenue in which the proceeds from the Offer will be utilised for our general working capital requirements, hedging costs and to defray cost and expenses for the Offer.

BEFORE INVESTING IN OUR STRUCTURED WARRANTS, YOU SHOULD CONSIDER CAREFULLY THE RISK FACTORS DESCRIBED BELOW AS WELL AS ALL OTHER RELEVANT INFORMATION CONTAINED ELSEWHERE IN THIS BASE PROSPECTUS AND THE RELEVANT TERM SHEETS.

Structured Warrants can be volatile instruments and may expire worthless. Our Structured Warrants are subject to a number of risks, including some or any combination of the risks set out below, any or all of which may result in a complete or partial loss of your investment in our Structured Warrants.

Your investment decision should be based solely upon your own independent assessment of our financial conditions and affairs, and your own appraisal of our prospects, our creditworthiness, the terms of the Deed Poll, the Underlying Equities, the Underlying ETFs, the Underlying Indices, basket of Underlying Equities, Bull ELS and any other factors relevant to your decision, including the merits and risks involved. In addition, in accordance with the Listing Requirements, Structured Warrants may be issued over foreign equities, ETFs and/or indices if the following criteria, *amongst others*, are met:-

- (i) the foreign equities and ETFs are listed or quoted on a Securities Exchange which is a member of the World Federation of Exchanges or is approved by Bursa Securities; or
- (ii) the foreign indices are based on a Securities Exchange which is approved by Bursa Securities and information on its composition and performance are made available to investors in Malaysia.

If you are in any doubt as to the action to be taken, you should consult your stockbroker, bank manager, solicitor, accountant or other professional advisers immediately.

[The rest of this page has been intentionally left blank]

6. RISK FACTORS

6.1 Risks Relating to Us

6.1.1 Credit risk

Our obligations in respect of the Structured Warrants represent general unsecured contractual obligations which rank equally with our other existing and future general unsecured and unsubordinated contractual obligations (save for certain obligations which are preferred by law).

If you subscribe for or purchase our Structured Warrants, you are therefore relying solely upon our creditworthiness as the issuer and of no other person. You do not have rights in the Underlying Instruments and/or have any recourse/right against the Underlying Companies, the Underlying Index Sponsor, Successor Underlying Index Sponsor or any of the companies constituting the Underlying Index, or the trustee, custodian, manager, registrar, service agent, participating dealer and/or other persons involved in constituting or undertaking the listing or trading of the Underlying ETF.

Accordingly, you must evaluate our credit risk in relation to our ability to fulfil our obligations under the Deed Poll and in respect of the Structured Warrants. Information on our credit rating profile is set out in Section 4.3 of this Base Prospectus. In this respect, you should note that credit ratings may be reassessed from time to time and may change. As credit ratings only assess credit risks, they should not be deemed to be a recommendation to invest in our Structured Warrants. Any downgrade in the rating accorded to our outstanding debt securities by our rating agency could result in a reduction in the price of the Structured Warrants. Accordingly, you should evaluate the Structured Warrants on your own or consult your investment adviser.

6.1.2 Trading by our Group

We or any other member within our Group may at any time purchase or buy-back the Structured Warrants in the open market or by tender or private treaty and become the Holder of the Structured Warrants. We may also trade in our Structured Warrants in our capacity as Market Maker.

We or any other member within our Group may trade the Underlying Equities, the Underlying ETFs or any other securities and financial products relating to any of the Underlying Companies, Underlying ETFs or Underlying Indices to hedge our position or to unwind any hedging that may be undertaken or for reasons not directly related to the Structured Warrants. These trading activities may affect (positively or negatively) the following:

- (i) the price at which the Underlying Equities or the Underlying ETFs (as the case may be) are traded on Bursa Securities or other Securities Exchange outside Malaysia;
- (ii) the price / level at which any other securities and financial products relating to any of the Underlying Companies, Underlying ETFs or Underlying Indices are traded on Bursa Securities or other Securities Exchanges outside Malaysia; or
- (iii) the price at which the Structured Warrants are traded on Bursa Securities.

6.1.3 Exercise of discretion by us

We may exercise our discretion to make adjustments to the Structured Warrants (for example, to the Exercise Price and Exercise Ratio of the Structured Warrants) in circumstances contemplated under the terms of the Deed Poll which could affect the price of the Structured Warrants for instance in the event of bonus issue, rights issue, subdivision or consolidation of the Underlying Equities (such as stock split or consolidation of stocks) or Underlying ETFs and capital repayment by the Underlying Companies or management companies of the Underlying ETFs.

We may also exercise our discretion to determine the applicable valuation period under the terms of the Deed Poll, which could affect the price of the Structured Warrants. For example, in the circumstance of Market Disruption Event, we may determine the valuation dates or relevant price or level as we deem fit to compute the Cash Settlement Amount.

6. RISK FACTORS *(cont'd)*

Holders do not have the power to direct us in respect of the exercise of our discretion, although in some cases, we may only exercise certain discretions with the consent of the relevant authorities.

You are advised to refer to Condition 6, Parts 1 to 7 of Annexure I of this Base Prospectus for circumstances that may result in the exercise of discretion by us.

6.1.4 No investigation or review performed on the Underlying Companies, the Underlying ETFs, the Underlying Index Sponsor or the companies constituting the Underlying Index

We have not carried out any investigation into or review on the business operations and prospects of the Underlying Companies. We have also not performed any investigation or review on the Underlying ETF, the Underlying Index Sponsor or the companies constituting the Underlying Index. Therefore, our issuance of any Structured Warrants does not represent a recommendation by us to invest in the Underlying Companies, the Underlying ETFs, the Underlying Indices or the companies constituting the Underlying Index.

In addition, you should be aware that:

- (a) the Underlying Company;
- (b) the Underlying Index Sponsor or the companies constituting the Underlying Index; or
- (c) the advisers, trustee, custodian, manager, registrar, service agent, participating dealer or other persons involved in constituting or the listing or trading of the Underlying ETF,

do not participate in establishing the terms and conditions of the Structured Warrants and they have no obligation with respect to the settlement amount to be paid to you (if any) upon exercise of the Structured Warrants, including any obligation to take into account, for any reason, our needs, or your needs.

Accordingly, your investment decision should be based solely upon your own independent assessment and appraisal of the Structured Warrants, the Underlying Companies, the Underlying ETF, the Underlying Index Sponsor and the companies constituting the Underlying Index. Investing in the Structured Warrants without adequate assessment and appraisals may lead to unanticipated losses that could have been avoided otherwise.

6.1.5 Potential conflict of interests

The nature of the business of our Group may give rise to a conflict of interests.

Our Group provides commercial banking and related financial services for our own account as well as for the account of our clients or customers.

Accordingly, from time to time in the course of our normal business dealings, we or the companies in our Group may:-

- (i) offer a full suite of customised debt and capital financing solutions which includes corporate bond issuances, loan syndication, structured finance, capital and project advisory services and primary syndication and underwriting services, which are not connected with our Structured Warrants, in relation to the Underlying Companies, the Underlying ETFs or companies constituting the Underlying Index;
- (ii) effect transactions for and/or buy and sell and/or hold positions in the Structured Warrants, the Underlying Equities, the Underlying ETFs, other securities and financial products relating to any of the Underlying Companies, or the Underlying Indices, either for our own account or for the account of our clients or customers;
- (iii) in connection with the offering of any Structured Warrants, also enter into one (1) or more hedging transactions with regard to the Underlying Equities and/or the Underlying ETFs or the shares of companies constituting the Underlying Index or with respect to related derivatives; and

6. RISK FACTORS *(cont'd)*

- (iv) introduce other derivative products in relation to the Underlying Companies, the Underlying ETFs or the Underlying Indices which may compete with our Structured Warrants and/or actively promote and offer other products, on our own behalf, to potential investors including to our existing clients which could give rise to a potential conflict of interests.

Any or all the above-mentioned activities and transactions may have resulted in a movement of the price / level of the Underlying Instruments. Any negative movement of the price / level of the Underlying Instruments may consequentially have an adverse effect on the price of our Structured Warrants.

Any profit earned and any loss incurred by us in our trading and advisory activities in relation to the Structured Warrants, the Underlying Equities, the Underlying ETFs, or otherwise, will accrue entirely to us independently of our obligations to the Holders.

In addition, our Group, in connection with its business activities, may possess or acquire material information about the Underlying Companies, Underlying Equities, Underlying ETFs or Underlying Indices. Such activities and information may involve or otherwise affect the Underlying Companies, Underlying Equities, Underlying ETFs or Underlying Indices in a manner that may have an adverse effect on the Structured Warrants. Our Group is not obliged to disclose such activities or information about the Underlying Companies, the Underlying Equities, the Underlying ETFs or Underlying Indices.

However, any potential conflict of interests above is mitigated by the following:-

- (i) all employees and directors of AmBank Group are required to comply with Management of Conflict of Interest Policy and Guidelines in which outline the minimum standards of identifying, managing, and controlling the potential conflict of interests to promote high standards of integrity and fair dealing;
- (ii) our Group has established Chinese walls to separate different business activities and control the flow or sharing of material, non-public and price-sensitive information between business activities and department within our Group. Chinese wall refers to both physical and non-physical barriers that separate different business activities and/or persons;
- (iii) our Group is governed by the FSA and the CMSA and is required to comply with strict policies, regulations and guidelines issued (from time to time) by the SC, Bursa Securities and BNM with regards to managing any potential conflict of interest situation.

6.1.6 Early termination due to liquidation, dissolution or winding-up of the Issuer

In the event of liquidation, dissolution, winding-up or appointment of a receiver and/or administrator in respect of the whole or substantial part of our undertakings, properties or assets, the outstanding and unexercised Structured Warrants will be deemed exercised early and, subject to the terms of the Deed Poll, settled in cash in an amount as determined by us. Hence, there is a risk that the Structured Warrants may be cancelled before the relevant expiry date of such Structured Warrants and cause you to suffer a loss or achieve a reduced profit.

You are advised to refer to Condition 11A of Part 1, Part 2 and Part 3, Condition 8 of Part 4, Condition 11 of Part 5 and Part 6, and Condition 11A of Part 7 of Annexure I to this Base Prospectus for more details relating to such events.

6.1.7 Take-over or scheme of arrangement or any other form of reorganization undertaken by the Issuer

In the event of a take-over or a scheme of arrangement or any other form of reorganization undertaken by or involving us or any other events having similar effects on the rights of the Holders, we may in our discretion make any adjustments to the rights attaching to the relevant Structured Warrants in a commercially reasonable manner. This may have a negative impact on the price of the relevant Structured Warrants.

6. RISK FACTORS (cont'd)

You are advised to refer to Condition 11A of Part 1, Part 2, Part 3, Condition 8 of Part 4, Condition 11 of Part 5 and Part 6 and Condition 11A of Part 7 of Annexure I of this Base Prospectus for more details relating to such events.

6.1.8 Merger, amalgamation or reconstruction involving the Issuer

There may be changes, such as change of name or transfer of assets, in the event of a merger, amalgamation or reconstruction involving us. However, the corporation, trust or other body into which we are merged, amalgamated or reconstructed shall assume all our liabilities and obligations in respect of the Structured Warrants so that the rights of the Holders shall continue to exist and be enforceable.

6.1.9 Legal and regulatory risks

Our Group consists of a group of companies carrying on diverse business activities. AmBank Group is subjected to potential legal actions and regulatory actions against its banking and non-banking entities arising from or in connection with their business activities and operations. As a result, any of these material legal actions and/or regulatory actions could have adverse financial and/or reputational effects on AmBank Group and/or any of the specific entities within AmBank Group.

Further, AmBank Group is subject to legal risk arising from changes in legislations and regulations. Changes in legislations and regulations could impose more stringent requirements or impose restrictions on our activities/business. This could have an adverse effect on the competitiveness and profitability of AmBank Group, which would in turn have an adverse effect on our business, financial condition, operations, and consequently our capability to meet the obligation in relation to the Structured Warrants.

6.1.10 Reputational risk

Reputational risk is the risk that a company will lose current and future business because its character or quality has been called into question and/or incur substantial financial penalties arising from the failure to comply with relevant laws and regulations. Any damage to the reputation of our Group may have an adverse effect on the financial performance and/or future prospects of our Group, consequentially affecting the price of our Structured Warrants.

Our parent company, AMMB, had on 26 February 2021, reached an agreement with the Ministry of Finance Malaysia for a sum of RM2.83 billion to be paid towards the full and final settlement in relation to the on-going review by the relevant authorities of overall transactions by 1Malaysia Development Berhad and its related entities with the AMMB Group (“**the Settlement**”). The Settlement charge of RM2,535.0 million that was apportioned to AmBank and AmBank Group has been fully provided in our financial results for the FYE 31 March 2021. The Settlement charge has been fully paid by AmBank as at the LPD.

We have restored our Core Capital Equity Tier 1 (“**CET1**”) and Total Capital Ratio pursuant to the equity injection of RM650.0 million from AMMB on 30 March 2021 by way of issuance of 66,394,280 new ordinary shares and the issuance of RM400.0 million Tier 2 debt capital.

Our Group remains resilient and highly liquid, with Liquidity Coverage Ratio of 150.00% and Net Stable Funding Ratio for all operating entities above 100%.

Our Group recognises that maintaining its reputation among clients, investors, regulators and the general public is an important aspect of minimising legal and operational risk. Maintaining the reputation depends on a large number of factors, including the selection of our clients and business partners and the conduct of our business activities. Our Group seeks to maintain its reputation by conducting our business activities in accordance with high ethical standards and regulatory requirements.

6. RISK FACTORS *(cont'd)*

6.1.11 Losses due to climate change

Climate change related impacts include physical risks from changing climatic conditions which could result from increased frequency and/or severity of adverse weather events. Such disasters could disrupt our Group's operations or the operations of customers or third parties on which our Group relies. Additionally, climate change could result in risks such as changes to laws and regulations, technology development and disruptions and changes in consumer and market preferences. Failure to effectively manage these risks could adversely affect the Issuer's business, prospects, reputation, financial performance or financial condition, which could in turn affect the price of the Structured Warrants.

6.2 Risks relating to our Structured Warrants**6.2.1 General investment risks**

If you are considering purchasing the Structured Warrants, it is recommended that you should have experience in warrant or option transactions and should reach an investment decision only after carefully considering, with your adviser, the suitability of the Structured Warrants for you. The Structured Warrants are considered to be suitable only for those who fully understand the risks involved and are prepared to sustain a complete loss of the subscription or purchase price paid for the Structured Warrants.

Investing in Structured Warrants is not equivalent to owning the Underlying Equities or having a direct investment in the Underlying Equities or Underlying ETFs or the companies constituting the Underlying Index. The market price of Structured Warrants is linked to the market price/level of the relevant Underlying Instruments and will be influenced (positively and negatively) by them. Further, the changes between the market price of the Structured Warrants and the market price/level of the Underlying Instruments may not be directly correlated and may be disproportionate. Fluctuations in the price/level of the Underlying Instruments will affect the price of the Structured Warrants but not necessarily in the same magnitude and direction.

6.2.2 Factors affecting the price of our Structured Warrants

The traded price of our Structured Warrants on Bursa Securities is dependent upon, amongst others, the liquidity, Exercise Price or Exercise level, the time remaining to expiration of the Structured Warrants, the volatility and liquidity of the Underlying Equities and the Underlying ETFs, the performance of the Underlying Indices, and the demand and supply of the Structured Warrants in the secondary market.

There is no assurance that the market price of the Structured Warrants will, upon and after Listing, be equal to or exceed the price paid by investors. The traded price of our Structured Warrants on Bursa Securities may fall in value as rapidly as they may rise and Holders may sustain a total loss of their investments. Changes in the price of the Underlying Equity and the Underlying ETF or the level of the Underlying Index can be unpredictable, sudden and large, and such changes may result in the price of the Structured Warrants to move in a direction which may have a negative impact on the return of your investment. If the price or level of the Underlying Equity, Underlying ETF or Underlying Index does not move in the anticipated direction, it will negatively impact the return on your investment. The loss, however, will be limited to the purchase price paid for the Structured Warrants and any relevant transaction costs.

Investing in Bull ELS involves market risk. Changes in the price of the Underlying Equity may result in the price of the Underlying Equity falling below the Exercise Price, which will negatively impact the return on the Bull ELS. In extreme circumstances, investors of Bull ELS may lose all, or a significant portion of their initial investment. Investors of Bull ELS should recognise that the Bull ELS may expire worthless or investors may end up with the Underlying Equity with a significantly lower market value than the Exercise Price.

Bursa Securities applies measures known as dynamic price limits aimed at preventing sudden fluctuation in price movement of securities trading on Bursa Securities, including the Structured

6. RISK FACTORS *(cont'd)*

Warrants. The dynamic price limits comprise of upper and lower thresholds and is continually updated based on a deviation of a percentage or absolute value from the last done prices of Structured Warrants during the main trading phase throughout the day. When an incoming Structured Warrants order is entered at a price outside of the prescribed dynamic price limits, the incoming order will be rejected and removed by the Bursa Securities trading system.

You are therefore advised to consider the above factors together with the related transaction costs carefully before dealing in the Structured Warrants.

6.2.3 Holders have no shareholder rights

Cash-settled Structured Warrants do not give Holders any rights to the Underlying Equities, the Underlying ETFs or the equities of the companies constituting the Underlying Index. We are not required or under any obligation to purchase, hold or deliver the Underlying Equities, the Underlying ETFs or the equities of the companies constituting the Underlying Index or any attached rights or benefits.

The Holders of Bull ELS and physical-settled Structured Warrants will not be constituted as shareholders of the Underlying Companies or the Underlying ETFs and will have no rights as shareholder of the Underlying Companies or the Underlying ETFs prior to the exercise of the warrants. Upon the exercise of the Bull ELS or physical settled Structured Warrants, such Holders will not have immediate rights with respect to the Underlying Equities or the Underlying ETFs until we transfer the Underlying Equities or the Underlying ETFs to the exercising Holders.

In addition, with respect to all Structured Warrants, there are no custody arrangements relating to the Underlying Equities, the Underlying ETFs or the equities of the companies constituting the Underlying Index. The Deed Poll does not create any security interest in favour of the Holders to secure the payment or delivery obligations under the Structured Warrants. Accordingly, if we become insolvent, Holders will not have any direct rights over the Underlying Equities, the Underlying ETFs and will merely rank equally as an unsecured creditor with other unsecured and unsubordinated creditors of ours.

6.2.4 Holders shall bear the risk of fluctuations in the price/level of the Underlying Instruments

The market price of the Structured Warrants at any time will be affected by, amongst others, fluctuations in the price/level of the Underlying Instruments. It is possible that in the event of the price/level of the Underlying Instruments increases, the value of the Structured Warrants decreases. The leverage provided by investing in the Structured Warrants means that a small percentage of change in the price or level of the Underlying Instruments may result in a larger percentage of change in the price of the Structured Warrants. As such, the return on your investment will be negatively affected and you may risk losing your entire investment if the price/level of the Underlying Instruments does not move in the anticipated direction. For example, a holder of a call warrant will gain if the price/level of the Underlying Instruments is higher than the Exercise Price or Exercise Level of the call warrants. A holder of a put warrant will gain if the price or level of the Underlying Instruments is lower than the Exercise Price or Exercise Level of the put warrants.

The Underlying Equity is a listed security and the Underlying ETF is a listed index-tracking fund. As such, sales of substantial numbers of the Underlying Equities and Underlying ETFs in the public market, or a perception in the market that such sales could occur, could adversely affect the prevailing market price of the Underlying Equities, Underlying ETFs which would in turn affect the performance of the Structured Warrants. The results of operations, financial condition, future prospects and business strategy of the Underlying Companies could affect the price of the Structured Warrants for so long as it is in relation to the Underlying Equities. The trading price of the Underlying Equities will be influenced by the Underlying Companies' operational results (which in turn are subject to the various risks in relation to their respective businesses and operations) and by other factors such as changes in the regulatory environment that can affect the markets in which the Underlying Companies operate and capital markets in general. Corporate events such as share sales, reorganisations or take-overs may also adversely affect the price of the Underlying Equity.

6. RISK FACTORS (cont'd)

Investors should be aware that the level of the Underlying Index may vary over time and is a function of the performance of the companies constituting the Underlying Index which are subject to the above risk factors. In addition, the level of the Underlying Index may increase or decrease by reference to various factors which may include changes in computation or composition of the index, economic factors and market trends.

6.2.5 Time decay

A Structured Warrant's price consists of intrinsic value and time value. Investors should be aware that Structured Warrant's time value decreases (decay) over time and will be closer to zero as it approaches its expiry date. As such, if you hold a Structured Warrant for a period of time, this decay may offset some or all of the gain caused by a movement in the Underlying Instruments.

6.2.6 Limited life of the Structured Warrants

The Structured Warrants have expiry dates and therefore, a limited life. For cash-settled Structured Warrants, if the Cash Settlement Amount on the expiry date after deducting all exercise expenses is greater than zero, the outstanding Structured Warrants will be deemed automatically exercised. However, if the Cash Settlement Amount on expiry date after deducting all exercise expenses is equal to or less than zero, all outstanding Structured Warrants will cease to be valid without any payment being made to Holders. For the avoidance of doubt, the Holders shall not be required to pay or top-up the exercise expenses, if any, as the case may be, where the Cash Settlement Amount after deduction of the exercise expenses, if any, is less than zero. For physical-settled Structured Warrants, any Structured Warrant not exercised during the exercise period will thereafter lapse and become void.

After the expiry date, our Structured Warrants will cease to be traded and can no longer be exercised, hence they will cease to have any value. It is possible that our Structured Warrants will expire without your expectations being realised.

6.2.7 Risk of "European style" Structured Warrants

European style Structured Warrants are only exercisable on its expiry date and not prior thereto. As such, the price of such Structured Warrants in the secondary market may be traded at a discount (or premium, as the case may be) to its estimated fair value in certain circumstances (including supply and demand factors). If the Cash Settlement Amount on a European style Structured Warrant is zero or below zero on the expiry date, you will lose the entire value of your investment.

6.2.8 Structured Warrants as hedging instruments for investor

If you intend to purchase Structured Warrants to hedge against the market risk associated with directly investing in / exposure to an Underlying Equity, Underlying ETF or Underlying Index, you should recognise the complexities and risk of utilising Structured Warrants in this manner. Due to fluctuating supply and demand for Structured Warrants, there is no assurance that the price of the Structured Warrants will correlate the movements of the Underlying Instruments. Hence, the Structured Warrants may not eliminate all market risk relating to the Underlying Instruments or a portfolio of investment consist of the Underlying Instruments.

6.2.9 Adjustments to the terms of the Structured Warrants under certain circumstances

An investment in the Structured Warrants involves valuation risks in relation to the Underlying Instruments. The price or level of the Underlying Instruments may change due to corporate actions such as:

- (a) corporate actions by the Underlying Companies (where the Underlying Instrument is an equity or a basket of equities);
- (b) changes in computation or composition of the Underlying Indices or corporate actions by the companies constituting the Underlying Indices (where the Underlying Instrument is an Index);
or

6. RISK FACTORS (cont'd)

- (c) corporate actions by the trustee of an Underlying ETF or otherwise (where the Underlying Instrument is an ETF).

Certain corporate actions such as bonus issues, rights issues and subdivisions or consolidation of shares of the Underlying Company or the units of the Underlying ETF may have a dilutive effect that causes the price of the relevant share or ETF unit to change, which may affect the economic value of the Structured Warrants. The terms of Deed Poll provides for protection against such dilutive effect via adjustments to the terms of the Structured Warrants with a view to maintaining the economic value of the Structured Warrants and counteract any such dilutive effect due to a corporate action.

Certain events relating to the Underlying Equities, Underlying ETFs or Underlying Indices (such as bonus issue, rights issue, subdivision or consolidation of equities/ETF units and capital repayment) permit us to make adjustments or amendments to amongst others, the Exercise Price or Exercise Level and/or Exercise Ratio of the Structured Warrants, as contemplated under the terms of the Deed Poll. You are advised to refer to Condition 6 of Parts 1 to 7 of Annexure I to this Base Prospectus and the Term Sheets for events that may cause adjustments to be made on the Exercise Price and Exercise Ratio of the Structured Warrant. However, we are not required to make an adjustment for every factor that affects the Underlying Instruments. Event of which no adjustment is made to the Exercise Price or Exercise Level and/or Exercise Ratio may cause the Structured Warrants to be out-of-the-money and/ or affect the trading price of the Structured Warrants and your return from the Structured Warrants. You are strongly advised to understand the effects of such adjustments on your investment in the Structured Warrants.

6.2.10 Suspension of trading in the Underlying Equity or Underlying ETF and/or Structured Warrants

If the trading in any of the Underlying Equity or Underlying ETF is suspended, then trading in the Structured Warrants on Bursa Securities may be suspended for a similar period if Bursa Securities deems such action appropriate in the interests of maintaining a fair and orderly market in the Structured Warrants, the Underlying Equity or the Underlying ETF or otherwise deems such action advisable in the public interest or to protect investors.

The trading of Structured Warrants over a single index may also be suspended for a similar period if:

- (a) the trading of options or futures relating to the relevant Underlying Index on any options or futures exchange is suspended; or
- (b) the relevant Underlying Index for whatever reason is not calculated.

If Bursa Securities does not, in such an event, suspend the trading of the Structured Warrants, we may still request for a suspension of the Structured Warrants.

The suspension of the trading of the:

- (a) Structured Warrants, the Underlying Equities or the Underlying ETFs on Bursa Securities; or
- (b) the Structured Warrants, the Underlying Equities or the Underlying ETFs on the relevant Securities Exchange outside Malaysia; or
- (c) the options or futures relating to the relevant Underlying Index on any options or futures exchange,

shall not preclude the Holders from exercising their rights under the Structured Warrants.

However, we may in our discretion make adjustments to the rights attaching to the Structured Warrants so far as we are reasonably able to do so without materially prejudicing the rights of Holders. Notice of such adjustments will be given to the Holders as soon as practicable.

You should be aware that closing price for the calculation of Cash Settlement Amount may vary if you intend to exercise your Structured Warrants during the suspension of trading in the Underlying Equity or Underlying ETF as a result of a take-over offer or compulsory acquisition. In the event that

6. RISK FACTORS *(cont'd)*

the suspension of trading in the Underlying Equity or Underlying ETF occurs on any of the valuation period immediately before expiry date, the Issuer shall determine the Cash Settlement Amount on the valuation period applicable and the closing price of the Underlying Equity or Underlying ETF, as it reasonably deem fit.

You are advised to refer to Conditions 2.1.3 and 2.2.2 of Parts 1, 2, 4 and 5, Condition 2.1.7 of Parts 3 and 6, and Condition 2.1.2 of Part 7 in Annexure I of this Base Prospectus and the Term Sheet for more details.

6.2.11 Possible early termination for illegality or impracticality

If we determine that the performance of our obligations under the Structured Warrants has become illegal or impractical in whole or in part, we may as we reasonably deemed fit, terminate the Structured Warrants early. In such event, we will, if and to the extent permitted by applicable law, pay an amount to the Holder if the Cash Settlement Amount after deducting all exercise expenses is greater than zero. The Cash Settlement Amount is determined by us to be the fair market value of the relevant Structured Warrants (less our costs) in accordance with the terms of the Deed Poll, notwithstanding the illegality or impracticality. Such early termination could cause you to suffer a loss or achieve a reduced profit.

You are advised to refer to Condition 19 of Parts 1, 2, 3, 5, 6 and 7 and Condition 16 of Part 4 in Annexure I of this Base Prospectus for more details relating to early termination of the Structured Warrants due to illegality or impracticality. You are strongly advised to understand the effects of such event.

6.2.12 Implications of the Take-Over Rules

If you intend to buy physical-settled Structured Warrants, you should bear in mind the implications of Rule 4, Part B of the Take-Over Rules and Sections 217 and 218 of the CMSA. These provisions generally regulate the acquisition of effective control of Malaysian public companies and you should consider the implications of these provisions before you buy and/or exercise the physical-settled Structured Warrants. If you have obtained control in the Underlying Company or triggered the creeping threshold (ie. Acquired more than 2% of shares of the Underlying Company in any period of 6 months when you already hold more than 33% but below 50% of shares of the Underlying Company) by buying and/or exercising physical-settled Structured Warrants, you are required by the Take-Over Rules to make a mandatory take-over offer on the Underlying Company.

6.3 Risks relating to the Underlying Companies, Underlying Equities, Underlying ETFs and Underlying Indices**6.3.1 Inherent risks relating to the Underlying Companies**

The Underlying Companies are subject to risks inherent to their respective industries. You should note that the occurrence of any material or adverse events in the industries of the Underlying Companies, may affect the performance of the relevant Underlying Equities and/or Underlying ETFs on the relevant Securities Exchanges, which may consequentially affect the value and/or performance of our Structured Warrants.

6.3.2 Limited information on the Underlying Companies, Underlying Equities, Underlying ETFs or Underlying Indices

Information and statements to be disclosed in the relevant Term Sheets such as the price or level relating to the Underlying Companies, Underlying Equities, Underlying ETFs and Underlying Indices will be obtained or extracted from publicly available third party sources such as a financial news service provider or financial information network provider. There can be no assurance on the timeliness, completeness of disclosure or availability of critical or material information on the Underlying Companies, Underlying Equities, Underlying ETFs or Underlying Indices, which was obtained from these third party sources.

6. RISK FACTORS *(cont'd)*

Hence, you should be aware that any delay in the transmission, incompleteness or unavailability of information and prices by the third party sources relied on by us for the purposes of market making may affect the performance of the Structured Warrants. You should also be aware that we have, in good faith, extracted relevant information and prices from the third party sources and therefore, have not independently verified such information.

You should make your own enquiries, and where appropriate, obtain prior advice in relation to any investment decision.

6.3.3 Take-over offer or compulsory acquisition of the Underlying Company

In the event of a take-over offer or compulsory acquisition of equities in an Underlying Company, no cancellation of the relevant Structured Warrants shall be effected and the Structured Warrants shall remain exercisable by the Holder for the remaining tenure of the exercise period, unless such take-over offer or compulsory acquisition results in the delisting, liquidation, dissolution or winding-up of the Underlying Company. However, if you intend to exercise your Structured Warrants during such a take-over offer period or compulsory acquisition period, you should be aware that calculation of closing prices of such equities may differ and consequently affect the Cash Settlement Amount.

6.3.4 Merger or consolidation of the Underlying Companies

In the event of a merger, amalgamation or reconstruction of the Underlying Company wherein an Underlying Company may:

- (i) merge with or into any other corporation;
- (ii) consolidate with or into any other corporation; or
- (iii) sell or transfer all or substantially all of its assets,

("Restructuring Event"), we may in good faith take any of the following actions:-

- (a) cancel the Structured Warrants and settle in cash if the Cash Settlement Amount after deduction of the exercise expenses, if any, is more than zero. The Cash Settlement Amount shall be determined by the Issuer based on the fair market value of the Underlying Equity after taking into account the Restructuring Event as we reasonably deem fit; or
- (b) make any adjustments to the rights attaching to the relevant Structured Warrants, in accordance with the terms of the Deed Poll. Notice of such adjustments will be given to the Holders as soon as practicable.

Hence, there is a risk that the Structured Warrants may be cancelled before the relevant expiry date of such Structured Warrants and cause you to suffer a loss or achieve a reduced profit.

You are advised to refer to Condition 8 of Part 1, Part 2, Part 3 and Part 7 of Annexure I to this Base Prospectus for more details relating to such events.

6.3.5 Delisting of Underlying Equities or Underlying ETFs and liquidation, dissolution or winding-up of the Underlying Companies or Underlying ETFs

For Structured Warrants over a single equity or a basket of equities or a single ETF, should:

- (i) the Underlying Equities or the Underlying ETF be delisted; or
- (ii) the Underlying Companies or Underlying ETF be liquidated, dissolved or wound-up; or
- (iii) a liquidator, receiver or administrator be appointed with respect to substantially the whole of the Underlying Companies' assets or the Underlying ETF's assets or to wind-up the Underlying Companies or the Underlying ETF,

6. RISK FACTORS *(cont'd)*

we may determine the outstanding Structured Warrants to be automatically exercised and settled in cash in accordance with the terms of the Deed Poll if the Cash Settlement Amount after deduction of the exercise expenses, if any, is more than zero. However, if the Cash Settlement Amount after deduction of the exercise expenses, if any, is equal to or less than zero, the outstanding Structured Warrants will cease to be valid without any payment made to Holders. For the avoidance of doubt, the Holders shall not be required to pay or top-up the exercise expenses, if any, as the case may be, where the Cash Settlement Amount after deduction of the exercise expenses, if any, is less than zero. It is possible that the Structured Warrants will be terminated before the expiry date of the Structured Warrants without the Holders' expectations being realised.

You are advised to refer to Condition 10 of Part 1, Part 2, Part 3, Part 5 and Part 7 and Condition 9 of Part 6 of Annexure I of this Base Prospectus for more details relating to such events.

6.3.6 Composition of Indices

A stock market index is a statistical measure of the performance of the capital market or certain sections of the capital market. Indices in a stock market are barometers used to measure the market's performance and movement. The composition of an index is determined by the Underlying Index Sponsor and may be changed to reflect prevailing circumstances. Examples of changes which may be made include changing a particular company's weighting in an index, the inclusion of new companies into an index and removal of companies from an index.

The methodology used in constructing an index may differ for different indices. As an index comprises a basket of selected companies, its performance is therefore specifically dependent on the performance of the companies within the index.

You should be aware that changes in the composition of indices such as inclusion of new companies into an index or changing the companies' weighting in an index by the Underlying Index Sponsor may have an adverse impact on the relevant Underlying Indices and consequently, on the price of the relevant Structured Warrants.

6.3.7 Compliance with the relevant laws and regulations by the Underlying Companies, the Underlying Index Sponsor or the Underlying ETFs

You should note that the Underlying Companies, Underlying Index Sponsor or the trustee, custodian, manager, registrar, service agent, participating dealer and/or other persons involved in constituting or undertaking the listing or trading of the Underlying ETFs, are subject to full compliance with the relevant laws, rules, regulations, guidelines, requirements or provisions imposed by the relevant authorities in Malaysia or in their home countries during the tenure of the Structured Warrants. The performance of the relevant Underlying Equities and/or Underlying ETFs on the relevant Securities Exchanges may be affected due to failure to comply with relevant laws and regulations in their respective jurisdictions, which may consequentially affect the value and/or performance of our Structured Warrants.

You should make your own enquiries, and where appropriate, obtain prior advice in relation to any investment decision.

6.3.8 Determining the Underlying Index level

Certain events relating to the Underlying Index (including a material change in the calculation of the Underlying Index level or a failure to publish the Underlying Index level) permit us to:-

- (a) determine the Underlying Index level on the basis of the formula or method of calculating the Underlying Index last in effect prior to such change; or
- (b) determine the Underlying Index level on the basis of the level of futures relating to the relevant index

Such changes may result in changing the companies' weighting in an index, the inclusion of new companies into an index and/or the removal of companies from an index. You should be aware that changes in the composition of indices may have an adverse impact on the relevant Underlying Index and the price of the relevant Structured Warrants.

6. RISK FACTORS *(cont'd)*

You are advised to refer to Section 6, Part 4 of Annexure I of this Base Prospectus for more details relating to events which could result in adjustments to the Structured Warrants on a single Underlying Index.

6.3.9 Risks relating to ETFs / ETF Structured Warrants / Underlying ETF Assets

6.3.9.1 General

An ETF is a listed index-tracking fund structured as a unit trust scheme or any other approved structures whose primary objective is to achieve returns that correspond to the performance of a particular index. Such ETFs may have different or additional risks and considerations compared to other types of Underlying Instruments. Some of these risks and considerations may include (but are not necessarily limited to) the following:-

- (i) For an index-tracking fund, the Underlying Index Sponsor will not be involved in the offer and sale of our Structured Warrants. The Underlying Index Sponsor may make an adjustment of the method for calculation of an index which could adversely affect the value of the ETF and hence the price of our Structured Warrants;
- (ii) Most ETFs are not actively managed and instead aim to match the performance of the specified index as closely as possible. Some ETFs may not track the performance of the specified index exactly because their holdings of assets may not exactly match the constituents of the index. This may lead to a discrepancy between the performance of the target index and the performance of the ETF. Hence, the price of our Structured Warrants may not exactly match the performance of the target index;
- (iii) ETFs may invest in a wide range of underlying assets including without limitation stocks, bonds, cash, commodities, currencies or derivatives in accordance with the objectives of the fund. As such, the performance of the ETF will reflect the risks and characteristics of the different underlying assets that it invests in;
- (iv) The price of an ETF may trade at a premium or discount to the ETF's net asset value due to supply and demand in the trading of the ETF. Hence, the price of our Structured Warrants may not exactly match the performance of the ETF's net asset value; and
- (v) The terms of the trust may allow creation or redemption of ETF units after the initial listing of the trust which will potentially affect the balance of market supply and demand of the ETF. The market supply and demand of ETF will affect the performance of the ETF, and consequentially the price of the Structured Warrants.

6.3.9.2 Yield

The return of the ETF Structured Warrants, unlike Underlying ETFs or the Underlying ETF Assets, are affected by factors such as gearing effect, time decay and volatility. You should be aware that the returns on the ETF Structured Warrants may not be directly comparable to returns that would be earned from investments directly made in the units of the Underlying ETFs or in the Underlying ETF Assets instead.

6.3.9.3 Derivatives risk

To achieve the investment objectives of the Underlying ETF, the management company of the Underlying ETF may use financial derivatives including, but not limited to, futures, forwards, options and swap contracts. The use of these derivative contracts bears certain risks, which may include the following:-

- (i) the inability to close out a futures and options contract caused by the non-existence of a liquid secondary market;

6. RISK FACTORS (*cont'd*)

- (ii) an imperfect correlation between price movements of the derivatives contracts with price movements of the Underlying ETF Assets;
- (iii) a relatively small price movement in a futures and options contract may result in immediate and substantial loss (or gain) to the Underlying ETF;
- (iv) if the management company purchases options and the options expire worthless, the Underlying ETF will suffer a total loss of its investment; and/or
- (v) counterparty risks associated with the use of derivatives contracts which may occur when the management company of the Underlying ETF enters into a derivatives contract and the counterparty does not settle a transaction in accordance with its terms and conditions or the transaction and derivatives techniques are terminated due to, *amongst others*, the following:-
 - (a) a dispute over the terms (whether in good faith or otherwise);
 - (b) a credit problem;
 - (c) the counterparty having declared a bankrupt or insolvent;
 - (d) liquidity problem;
 - (e) illegality; or
 - (f) change in the tax accounting laws from the time the transaction was entered into.

The above risks may increase in adverse market conditions and in the event that the risk materialises, the net asset value per unit of the Underlying ETF may be adversely affected and consequently you may sustain a loss on your investment in the ETF Structured Warrants.

6.3.9.4 Tracking error risk

Changes in the Underlying ETF prices may not perfectly trail the changes in the price / level of its underlying index or benchmark that the ETF is designed to track and consequently affect the value of the ETF Structured Warrants. This is due to, *amongst others*, the following factors:-

- (i) the fund management and trading fees incurred by the Underlying ETF;
- (ii) mismatch of the Underlying ETF portfolio holdings against the holdings of its underlying index or benchmark; and/or
- (iii) the level of the volatility of its underlying index or benchmark.

You may suffer losses if a tracking error has occurred and it affects the value of the ETF Structured Warrants.

6.3.9.5 Risks associated with certain Underlying ETF Assets

Certain risks (e.g. risks on shares, pooled investment vehicles, indices, real estate, commodities, structured finance securities and others) may be associated with investment in particular Underlying ETF Assets as set out herein:-

- (i) Shares

Market and economic conditions, industry sector, geographical region and political events are among a number of factors which could affect the value of the shares constituting the Underlying ETF Assets and the Underlying ETF units and consequently, the value of the ETF Structured Warrants.

6. RISK FACTORS (cont'd)

(ii) Pooled investment vehicles

Alternative investment funds, mutual funds and similar investment vehicles operate through the pooling of investors' assets.

If the investment is invested using a variety of hedging strategies and/or techniques, such hedging strategies and/or techniques can be speculative and may not be an effective hedge. This may involve substantial risk of loss and limit the opportunity for gain which may affect the value of the Underlying ETF and consequently, the value of the ETF Structured Warrants.

(iii) Indices

Indices are indicators or measurement of the performance of the constituents they cover.

The compilation and the calculation of an index or portfolio will generally be rule based, account for fees and include discretions exercisable by the Underlying Index Sponsor or portfolio manager. There is no assurance that an index will continue to be calculated and published or that it will not be amended significantly. Any change to an index may adversely affect the value of such Underlying ETF which will in turn affect the value of the ETF Structured Warrants.

Some Underlying ETFs gain exposure to the Underlying Indices by investing in financial derivatives instruments linked to the performance of the Underlying Indices. You should refer to 6.3.9.3 Derivatives risk to understand the risks relating to the use of financial derivatives by an Underlying ETF.

(iv) Real estate

The Underlying ETF may be constituted by direct or indirect investment in real estate. Any investment in real estate may be affected by the cyclical nature of real estate values, changes in the environments, planning, landlord and tenant, tax or other laws or regulations affecting real property, demographic trends, variation in rental income and increases in interest rates. This may influence the price of the Underlying ETF units and consequently, the value of the ETF Structured Warrants.

(v) Commodities

Investments in commodities may be subject to greater volatility than investments in traditional securities. The reasons that cause such volatility to the prices of commodities are, *amongst others*, various macro economic factors such as changing supply and demand relationships, climatic and geopolitical conditions, disease, and other natural phenomena, agricultural, trade, fiscal, monetary, and governmental restrictions in foreign exchange and policies of governments (including government intervention in certain markets) and other unforeseeable events. Such factors may influence the price of the Underlying ETF units and consequently, the value of the ETF Structured Warrants.

(vi) Structured finance securities

Structured finance securities include, without limitation, asset-backed securities and credit-linked securities which may entail a higher liquidity risk than sovereign or corporate bonds. Where the Underlying ETF Asset is a structured finance security, the value of, or the amounts paid on such security may be affected by the performance of assets referenced by such security.

6. RISK FACTORS *(cont'd)*

(vii) Others

There may be other Underlying ETF Assets which carry substantial financial risk such as distressed debt, low quality credit securities, forward contracts and deposits with commodity trading advisors (in connection with their activities). As some of these assets may be volatile and illiquid, there may be a possibility that these assets may underperform significantly and hence the value of the Underlying ETF will be adversely affected. This will in turn affect the value of the ETF Structured Warrants.

6.3.9.6 Merger or consolidation of the Underlying ETF

If an announcement is made that:-

- (i) the Underlying ETF is to or may merge with or into any other ETF;
- (ii) the Underlying ETF consolidates with or into any other ETF; or
- (iii) all or substantially all of the Underlying ETF assets are or may be sold or transferred, (“**Restructuring Event**”), we may in good faith take any of the following actions:-

- (i) cancel the Structured Warrants and settle in cash if the Cash Settlement Amount after deduction of the exercise expenses, if any, is more than zero. The Cash Settlement Amount shall be determined by the Issuer based on the fair market value of the Underlying ETF after taking into account the Restructuring Event as we reasonably deem fit; or
- (ii) make any adjustments to the rights attaching to the terms and conditions of the Structured Warrants to account for the Restructuring Event.

Hence, there is a risk that the Structured Warrants may be cancelled before the relevant expiry date of such Structured Warrants. As a result thereof, the value of the ETF Structured Warrants may be adversely affected and/or you may lose some or all of your investment in the ETF Structured Warrants.

You are advised to refer to Condition 8 of Part 5 and Part 6 of Annexure I to this Base Prospectus for more details relating to such events.

6.4 Other risks

6.4.1 Delay in or abortion of the listing of our Structured Warrants

The occurrence of certain events, including the following, may cause a delay in or abortion of the Listing of each series of our Structured Warrants:-

- (i) we are unable to meet the public spread requirement as stipulated by Bursa Securities that:
 - (a) each series of the Structured Warrants must be held by at least hundred (100) Holders holding not less than one (1) board lot of the relevant series of Structured Warrants each, or
 - (b) at least fifty (50) Holders holding not less than one (1) board lot each provided that each of these Holders subscribes for a minimum of RM100,000 of the relevant series of Structured Warrants each, or
 - (c) or such other public spread requirement of Bursa Securities as amended from time to time is not met; or
- (ii) the minimum subscription of a total face amount of RM5 millions of our Structured Warrants, or such other minimum subscription face amount as required by Bursa Securities from time to time, is not met.

6. RISK FACTORS *(cont'd)*

Although we will endeavour to ensure compliance with the various regulatory requirements, no assurance can be given that these factors will not cause a delay in or abortion of the Listing of our Structured Warrants on Bursa Securities.

For Structured Warrants issuance made by way of placement, where you have made payment for the application of the Structured Warrants prior to its Listing, the delay in the Listing of the Structured Warrants may cause opportunity lost to you, amongst others, where the movement in price of the Underlying Instruments are in your favour and you would not be able to realize the gain in Structures Warrants. In the event that we have to abort the Listing of the Structured Warrants, the monies paid in respect of your application will be returned to you without reimbursement of interest payment.

In the event of a delay in the Listing of the Structured Warrants for any reason, we will notify you immediately and work towards minimizing any such delay. In the event that we have to abort the issue or listing of the Structured Warrants, we will notify you and all monies paid in respect of your application will be returned to you without interest within fourteen (14) days after the close of the Offer.

6.4.2 Political and economic factors

Adverse local and abroad political and economic conditions or developments, which include an unstable political environment, nationalisation (i.e. the transfer of a private asset or industry to the public ownership or control of a government or state) and severe fluctuations in interest and currency exchange rates, may create uncertainty and could discourage the free flow of investment capital. These would affect international trade and ultimately resulting in adverse developments in economic activity. Subsequently, these may have material adverse impact on the financial performance and/or business prospects of the Underlying Companies. The same factors may also materially and adversely affect the performance of the Underlying Indices or Underlying ETFs. Such factors may negatively impact the price/level of the Underlying Instruments and consequentially may affect the price of the Structured Warrants.

6.4.3 Settlement Disruption Event and Market Disruption Event

You should note that the occurrence of Market Disruption Event can delay the determination of the closing price and consequently the payment of the Cash Settlement Amount or delivery of the Physical Settlement Amount to you upon exercise of the Structured Warrants.

The occurrence of Settlement Disruption Event will also delay the payment of the Cash Settlement Amount or delivery of the Physical Settlement Amount to you upon exercise of the Structured Warrants.

Subject to the terms of Deed Poll, the occurrence of a Market Disruption Event shall entitle us to determine as we reasonably deem fit the closing price, exchange rate and/or valuation period for the relevant Structured Warrants which consequently may adversely affect the Cash Settlement Amount or Physical Settlement Amount.

Please see Condition 2 of Part 1 to 7 of Annexure I to this Base Prospectus for more details relating to such event.

6.4.4 Exchange rate risk

There will be exchange rate risk when the Underlying Instrument is denominated in foreign currency and the Cash Settlement Amount is converted into RM. The conversion may potentially result in foreign exchange losses if there is any adverse movement in the exchange rate. Any foreign exchange losses will be borne by the Holders. Exchange rates between currencies are determined by forces of supply and demand in the foreign exchange markets. These forces are, in turn, affected by factors such as international balances of payments and other economic and financial conditions, government intervention in currency markets and currency trading speculation.

6. RISK FACTORS *(cont'd)*

Fluctuations in foreign exchange rates, foreign political and economic developments, and the imposition of exchange controls or other foreign governmental laws or restrictions may affect the foreign currency market price and the exchange rate-adjusted equivalent price of the Structured Warrants.

6.4.5 Foreign law / regulatory policy risks

Where the Underlying Companies or the Underlying Instruments involve companies or indices or shares in a market outside of Malaysia which have legal and regulatory regimes different from that of Malaysia, your investment in the relevant Structured Warrants may be exposed to greater risks through changes in law and regulatory policies as compared with Structured Warrants investments which are only in respect of Malaysian securities.

We have not performed any investigation or review of the business operations and prospects of the Underlying Companies. We have also not performed any investigation or review on the Underlying ETFs, the Underlying Index Sponsor and/or the companies constituting the Underlying Indices. Therefore, our issuance of any Structured Warrants does not represent our responsibility, representation or warranty (whether express or implied) that the Underlying Companies or Underlying Index Sponsor or the trustee, custodian, manager, registrar, service agent, participating dealer and/or other persons involved in constituting or undertaking the listing or trading of the Underlying Equities, Underlying ETFs and/or Underlying Indices, have fully complied / fully comply with the relevant laws, rules, regulations, guidelines, requirements or provisions imposed by the relevant authorities in their home countries during the tenure of the Structured Warrants.

The performance of the relevant Underlying Equities and/or Underlying ETFs on the relevant Securities Exchanges may be affected due to failure to comply with relevant laws and regulations by the Underlying Companies, the ETF Managers or the Underlying Index Sponsor in their respective jurisdictions, which may consequentially affect the value and/or performance of the Structured Warrants.

6.4.6 Nationalisation

Nationalisation involves the transfer of a private asset or industry to the public ownership or the control of a government or state. If nationalisation occurs in relation to the relevant Underlying Company:-

- (a) we retain the discretion to determine the appropriate adjustment, if any, to be made to any one or more of the Conditions of Annexure I to this Base Prospectus to account for the nationalisation, and determine the effective date of that adjustment. We may, but are not obliged to, determine the appropriate adjustment by reference to the terms of the Deed Poll; or
- (b) the Structured Warrants may be early exercised and settled in cash if it is in-the-money at the relevant time; or
- (c) we retain the discretion to refrain from taking any action where the Underlying Equities and/or Underlying ETFs of such Underlying Companies continue to be listed at the relevant Securities Exchange(s).

6.4.7 Potential tax implications

The buy and sell transactions of Structured Warrants on Bursa Securities are subjected to stamp duty. In addition, income tax or capital gain tax treatment may vary depending on the legal identity of an investor, or the classification of income from the investment of Structured Warrants by the relevant tax authorities.

From time to time, tax laws and regulations as well as their application by the relevant taxation authorities are subjected to changes. If you are in doubt, please consult your own independent tax advisers on your tax position considering your individual circumstances before investing in

6. RISK FACTORS *(cont'd)*

Structured Warrants.

6.4.8 COVID-19 endemic and possible similar future outbreaks

The ongoing COVID-19 endemic and any possible future outbreaks of disease may have significant adverse effect on the financial and business prospects of an Underlying Company. This may affect the performance of the Underlying Equities, Underlying Indices or Underlying ETFs which would in turn affect the price of the Structured Warrants.

The ongoing COVID-19 endemic and any possible future outbreaks could also affect AmBank's profits and financial position, hence potentially AmBank's ability to perform its obligations in respect of the Structured Warrants. Should the impact of the ongoing COVID-19 endemic and any possible future outbreaks on global market conditions be continued or worsen, or lead to additional market disruption, AmBank could experience negative impacts to operations, financial position and prospects. Any material or prolonged negative conditions may lead to constraints on the Issuer's capital and liquidity, a downgrade in credit ratings and an increased cost of capital. Accordingly, you should evaluate the Structured Warrants on your own or consult your investment adviser.

6.4.9 Combination of risk factors

Two (2) or more risk factors may simultaneously have an effect on the value of a Structured Warrant. As such, the effect of any combination of risk factors on the value of the Structured Warrants may be unpredictable.

[The rest of this page has been intentionally left blank]

7. APPROVALS AND CONDITIONS

We have registered a copy of this Base Prospectus with the SC. A copy of this Base Prospectus has also been lodged with the ROC who takes no responsibility for its contents.

We will be applying to the SC for registration of each Term Sheet to be issued pursuant to an Offer. A copy of each Term Sheet will also be lodged with the ROC.

We will be applying to Bursa Securities for the issuance and admission of the relevant series of Structured Warrants pursuant to an Offer to the Official List of Bursa Securities, for permission to deal in the Structured Warrants, and for the Listing.

[The rest of this page has been intentionally left blank]

8. DECLARATION BY THE SOLICITORS

8.1 Solicitors

Messrs. Zaid Ibrahim & Co. (in association with KPMG Law) has been appointed as our Solicitors in respect of the Offer and has given confirmation that there is no conflict of interests in its capacity as our Solicitors in respect of the Offer.

[The rest of this page has been intentionally left blank]

9. ADDITIONAL INFORMATION

9.1 Material Litigation

As at the LPD, there is no litigation, arbitration or claims of material importance pending or threatened against any company within our Group, which is outside the ordinary course of business and which has or will have a material effect on our ability to meet our obligations under the Structured Warrants. In addition, our Board is not aware of any facts likely to give rise to such material litigation, arbitration or claims.

9.2 Material contracts

As at LPD, AmBank Group has not entered into any material contracts which are outside the ordinary course of business for the last three (3) financial years covered in Section 4.8 up to the date of this Base Prospectus.

9.3 Consents

The Auditors, Company Secretary, Solicitors for the Offer, Structured Warrants Registrar and RAM Ratings have, before the issuance of this Base Prospectus, given and have not subsequently withdrawn their written consents to the inclusion in this Base Prospectus of their names, statements and reports in the form and context in which such names, statements and reports appear.

9.4 Documents for Inspection

Copies of the following documents may be inspected at our registered office during normal business hours for a period of twelve (12) months from the date of this Base Prospectus:-

- (i) Our Constitution;
- (ii) Deed Poll;
- (iii) Warrant Agency Agreement dated 2 May 2018;
- (iv) The letters of consent referred to in Section 9.3 of this Base Prospectus;
- (v) Our Group's audited financial statements for the FYE 31 March 2021 to 31 March 2023 and unaudited financial statements for the three (3) months FPE 30 June 2023.

9.5 General

We will not allot nor issue any securities on the basis of this Base Prospectus later than twelve (12) months from the date of this Base Prospectus.

9.6 Responsibility Statement

- (i) We acknowledge that, based on all available information and to the best of our knowledge and belief, this Base Prospectus constitutes a full and true disclosure of all material facts concerning the Offer.
- (ii) Our Directors have seen and approved this Base Prospectus. Our Directors collectively and individually accept full responsibility for the accuracy of the information contained in this Base Prospectus and confirm, having made all reasonable enquiries that to the best of their knowledge and belief, there are no false or misleading statements or other facts the omission of which would make any statement in this Base Prospectus false or misleading.

ANNEXURE I PRINCIPAL TERMS OF THE DEED POLL

The Structured Warrants are governed by the detailed provisions of the Deed Poll. Copies of the Deed Poll are available for inspection at our registered office during normal business hours from Monday to Friday (except public holidays) and prospective investors are advised to read the Deed Poll in its entirety. Holders are bound by and are deemed to have notice of all provisions contained in the Deed Poll. The following is an extract of the principal terms of the Structured Warrants from the Deed Poll.

In these Conditions, the following expressions shall unless the context requires otherwise have the meanings set opposite them:

Term	Definition
AmBank Group	the Issuer and its subsidiaries;
American style	in respect of the right of the Holder of a Structured Warrant, the ability to exercise that right at any time from its issue date up to and including the Expiry Date;
Assets	all assets and property of any nature, whether present or future, including without limitation any undertaking, business, revenue, income, rights and benefits;
Base Prospectus	the base prospectus dated 29 September 2023 to be issued by the Issuer in respect of the Structured Warrants, which is valid until 28 September 2024 as updated or amended from time to time by way of successor documents, and as supplemented by the Issuer from time to time by a Term Sheet for each Series of Structured Warrants;
Bull ELS	Bull equity-linked structures;
Bursa Depository	Bursa Malaysia Depository Sdn Bhd (Registration No. 198701006854 (165570-W));
Bursa Securities	Bursa Malaysia Securities Berhad (Registration No. 200301033577 (635998-W));
Business Day	in relation to provisions on Market Disruption Event, means a day (other than Saturday, Sunday or public holiday) on which licensed financial institutions of the Relevant Country are open for banking business and where applicable, a day on which the Underlying Index is published by the Underlying Index Sponsor and where the Underlying Index closes at normal trading hours;
Cash Settlement Amount	the amount of cash to be paid to the Holder on valid exercise of the Structured Warrants in accordance with Condition 2 of Part 1, Part 2, Part 3, Part 4, Part 5, Part 6 and Part 7 of the Third Schedule, as the case may be;
Cash Settlement Amount for Odd Lots	the amount of cash to be paid to the Holder for odd lots of Underlying Equity or Underlying ETF on valid exercise of the Structured Warrants in accordance with Condition 2 of Part 3 and Part 5 of the Third Schedule, as the case may be;
Central Depositories Act	the Securities Industry (Central Depositories) Act 1991;
Compulsory Acquisition	the compulsory acquisition of all the equities not already owned in the Underlying Company;

ANNEXURE I PRINCIPAL TERMS OF THE DEED POLL (cont'd)

Compulsory Period	Acquisition	a period from the date of a notice of a Compulsory Acquisition has been served on the Underlying Company up to the completion of the Compulsory Acquisition;
Conditions		in relation to a Series of Structured Warrants, the terms and conditions applicable thereto being in or substantially in the form set out in Part 1, Part 2, Part 3, Part 4, Part 5, Part 6 and Part 7 of the Third Schedule, as the case may be, as may from time to time be modified in accordance with this Deed Poll and/or the Conditions, and “ Condition ” followed by a number refers to the relative numbered paragraph of the Conditions;
Deed Poll		this deed poll as amended, modified or supplemented from time to time in accordance with the provisions of this deed poll, and includes any Term Sheet to supplement this deed poll which sets out the terms and conditions of a specific Series of Structured Warrants;
Depositor		a holder of a Securities Account;
European style		in respect of the right of the Holder of a Structured Warrant, the ability to exercise that right on the Expiry Date or in relation to physical-settled Structured Warrants, the ability to exercise that right on the Expiry Date up to 9.00 a.m. on the fifth (5 th) Market Day following the Expiry Date;
Event of Default		a default by the Issuer in the performance of any of its settlement obligations under this Deed Poll;
Exercise Date		in relation to a Series of Structured Warrants, the date upon which the Structured Warrant is or is to be treated as exercised, being a Market Day during the Exercise Period or if such a day is not a Market Day it shall be deemed to be exercised the next following Market Day subject to the Conditions;
Exercise Expenses		all costs and expenses reasonably incurred in respect of the exercise of the Structured Warrants as may be charged by the Issuer and/or any taxes or duties, if any, (which are payable under any applicable law including but not limited to service tax or goods and services tax);
Exercise Form		the form for exercising the Structured Warrants in the form or substantially in the form contained in the Second Schedule as may from time to time be modified by the directors of the Issuer in accordance with this Deed Poll;
Exercise Level		in relation to a Series of Structured Warrants, the pre-specified level as determined by the Issuer at which the Holders may exercise the right under the Series of Structured Warrants subject to any adjustment as may be necessary in accordance with the Conditions and as specified in the relevant Term Sheet;
Exercise Period		in relation to a Series of Structured Warrants, the period during which the Holders of the Structured Warrants may exercise the relevant Structured Warrants and as specified in the relevant Term Sheet, provided in the case of an exercise of European style Structured Warrants or Bull ELS, a reference to Exercise Period shall mean 5.00 p.m. on the Expiry Date only;
Exercise Price		in relation to a Series of Structured Warrants, the pre-specified price as determined by the Issuer at which the Holders may exercise the right under the Series of Structured Warrants subject to any adjustment as may be necessary in accordance with the Conditions and as specified in the relevant Term Sheet;

ANNEXURE I PRINCIPAL TERMS OF THE DEED POLL (cont'd)

Exercise Ratio	in relation to a Series of Structured Warrants, the number of Structured Warrants to which one Underlying Equity, one basket of Underlying Equities, one Underlying ETF unit or one Underlying Index unit (as the case may be) relates as determined by the Issuer and as specified in the relevant Term Sheet;
Exercise Rights	<p>(a) in relation to physical-settled Structured Warrants and Bull ELS, the right granted to the Holder (which is exercisable during the Exercise Period) to receive Physical Settlement Amount, Cash Settlement Amount for Odd Lots and/or Cash Settlement Amount, as the case may be;</p> <p>(b) in relation to cash-settled Structured Warrants, the right granted to the Holder (which is exercisable during the Exercise Period) to receive the Cash Settlement Amount;</p>
Expiry Date	in respect of a Series of Structured Warrants, the date of expiry of the Series of Structured Warrants to be determined by the Issuer and as specified in the relevant Term Sheet, provided that if such date is not a Market Day the Expiry Date shall be the next succeeding Market Day (subject to the provisions herein as to the valuation of the Underlying Equity, the Underlying ETF or the Underlying Index, as the case may be);
Holder(s)	the person or persons whose names for the time being appear on the Record of Depositors for the Structured Warrants;
Issuer	AmBank (M) Berhad (Company No. 196901000166 (8515-D)), a company incorporated in Malaysia with its registered office at 22nd Floor, Bangunan AmBank Group, No. 55, Jalan Raja Chulan, 50200 Kuala Lumpur, Malaysia;
Market Day	<p>a day (other than Saturday, Sunday or public holiday) on which the relevant Securities Exchange(s) is/(are) open for trading during the normal trading hours in the respective place where the relevant:</p> <p>(a) Underlying Equity(ies) is/(are) quoted and traded;</p> <p>(b) Underlying ETF is quoted and traded; or</p> <p>(c) Underlying Index is compiled and published,</p> <p>as the case may be, and the Structured Warrants are quoted and traded;</p>
Market Disruption Event	<p>shall include but is not limited to any of the following events:</p> <p>(a) where the underlying financial instrument of a Series of Structured Warrants is an Underlying Equity or Underlying ETF (as the case may be), any suspension of or limitation imposed on trading by the relevant Securities Exchange and whether by reason of price movements exceeding the limits permitted by the Securities Exchange relating either to the Underlying Equity or the Underlying ETF (as the case may be), or Structured Warrants (as determined by the Issuer) quoted and traded on the Securities Exchange or otherwise;</p> <p>(b) where the underlying financial instrument of a Series of Structured Warrants is an Underlying Index, the occurrence or existence on any Market Day at the time by reference to which the Issuer determines the level of the relevant Underlying Index or the prices of the equities constituting the Underlying Index</p>

("Relevant Time") for such Underlying Index or such equities constituting the Underlying Index:

- (i) of any suspension of or limitation imposed on trading such as:
 - (A) the suspension or material limitation on the trading of a material number of the equities constituting the Underlying Index;
 - (B) the suspension or material limitation on the trading of the securities constituting the Underlying Index on the relevant Securities Exchange;
 - (C) the suspension or material limitation on relevant Securities Exchange on the trading of options contracts or futures contracts relating to the Underlying Index or equities relating to the Underlying Index on which such contracts are traded; or
 - (D) the imposition of any exchange controls in respect of any currencies involved in determining the Cash Settlement Amount;
- (c) any event (other than an event described in (d) below) that disrupts or impairs (as determined by the Issuer) the ability of market participants in general:
 - (i) where the underlying financial instrument of a Series of Structured Warrants is an Underlying Equity or Underlying ETF (as the case may be), to effect transactions in or to obtain market prices of the Underlying Equity or the Underlying ETF, as the case may be or to effect any security transactions on the relevant Securities Exchange; or
 - (ii) where the underlying financial instrument of a Series of Structured Warrants is an Underlying Index, to effect transactions in relation to or to obtain market levels for the Underlying Index on the relevant Securities Exchange or to effect transactions in or obtain market quotes for options contracts or futures contracts on or relating to the relevant Underlying Index on the relevant Securities Exchange;
- (d) the closure on any Market Day of the relevant Securities Exchange prior to the Scheduled Closing Time unless such earlier closing time is announced by such Securities Exchange at least one half hour prior to:
 - (i) the actual closing time for the regular trading session on the relevant Securities Exchange on such Market Day; or
 - (ii) the submission deadline (if applicable) for orders to be entered into the relevant Securities Exchange system for execution on such Market Day,

whichever is earlier.

ANNEXURE I PRINCIPAL TERMS OF THE DEED POLL (cont'd)

The “**Scheduled Closing Time**” is the scheduled weekday closing time of the relevant Securities Exchange, without regard to after hours or any other trading outside of the regular trading session hours;

- (e) a general moratorium is declared in respect of banking activities in any Relevant Country; or
- (f) where the Relevant Country:
 - (i) imposes any controls or announces its intention to impose any controls; or
 - (ii) implements or announces its intention to implement, or changes or announces its intention to change the interpretation or administration of any laws or regulation,

which the Issuer determines is likely to affect AmBank Group to acquire, transfer, hold or realise such Underlying Equity, the Underlying ETF or equities constituting the Underlying Index, as the case may be, or to effect transactions in relation to the Underlying Equity, the Underlying ETF or the Underlying Index, as the case may be.

Where the financial instrument of a Series of Structured Warrants is an Underlying Index, the Issuer may have regard to such circumstances as it reasonably deems fit, including any hedging arrangements by AmBank Group in relation to the Structured Warrants, to determine whether any of the foregoing events is “**material**”. Where any of the foregoing events affect fifteen percent (15%) or more of the level of such Underlying Index, the Issuer will regard it as material. If the Issuer determines, that on any valuation date, a Market Disruption Event has occurred in respect of the Underlying Index, then the valuation date in respect of such Underlying Index shall be the next following Market Day after the Market Disruption Event occurred;

Official List	a list specifying all securities listed on the Main Market of Bursa Securities;
Physical Settlement Amount	the number of Underlying Equity or the Underlying ETF, as the case may be, to be delivered to the Holder on valid exercise of the Structured Warrants in accordance with Condition 2 of Part 3 or Condition 2 of Part 6 of the Third Schedule;
Prescribed Security	a security which has been prescribed by Bursa Securities to be deposited with Bursa Depository under section 14 of the Central Depositories Act;
Record of Depositors	the record provided by Bursa Depository to the Issuer or the Structured Warrants Registrar under the Rules of Bursa Depository;
Relevant Country	means: <ul style="list-style-type: none"> (a) any country (or any political or regulatory authority thereof) in which the Relevant Currency or the Settlement Currency is the legal tender or currency of the country; or (b) any country (or any political or regulatory authority thereof) with which the Underlying Equity(ies), the Underlying ETF or the Underlying Index, as the case may be, has(have) a material connection and, in determining what is material, the Issuer, may without limitation, refer to:

ANNEXURE I PRINCIPAL TERMS OF THE DEED POLL (cont'd)

	<ul style="list-style-type: none"> (i) the country in which the Underlying Equity(ies) is(are) listed; (ii) the country in which the Underlying Company is incorporated; (iii) the country in which the Underlying ETF is listed; (iv) the country in which the Underlying Index is compiled or published; or (v) the country in which a material number of securities constituting the Underlying Index are listed, <p>as the case may be, and/or such other factor(s) as it may deem appropriate,</p> <p>as determined by the Issuer;</p>
Relevant Currency	such currency of trading to which the Underlying Equity, the Underlying ETF or the Underlying Index, as the case may be, relates and as specified in the relevant Term Sheet;
Rules of Bursa Depository	the Rules of Bursa Depository as issued under the Central Depositories Act;
SC	Securities Commission Malaysia;
Securities Account	an account established by Bursa Depository for a Depositor for the recording of deposits of securities and for dealing in such securities by the Depositor as permitted under the Central Depositories Act and/or the Rules of Bursa Depository;
Securities Exchange(s)	such exchange(s) or quotation system(s) in Malaysia or securities exchange(s) outside Malaysia in which the Underlying Equity(ies) is(are) quoted and/or traded, the Underlying ETF is quoted and/or traded or the Underlying Index is compiled or published, as the case may be, or Structured Warrants are quoted and/or traded as specified in the relevant Term Sheet;
Series of Structured Warrants	all those Structured Warrants which are governed by the same Term Sheet;
Settlement Currency	such currency, upon which payment is made to the Holder, to be determined by the Issuer and as specified in the relevant Term Sheet;
Settlement Date	a Market Day and a day upon which payment is made to the Holder, on which commercial banks in Malaysia and if applicable, the Relevant Country, are open for business during normal business hours;
Settlement Disruption Event	<p>any of the following events:</p> <ul style="list-style-type: none"> (a) the Issuer experiences technical difficulties in the course of processing a valid exercise of the Structured Warrants; or (b) any other event beyond the Issuer's control arising after the Exercise Form is delivered to the Structured Warrants Registrar by the Holder or arising on the Expiry Date (as the case may be) including but not limited to where the Relevant Currency is different from the Settlement Currency, any event which occurs at any time (as determined by the Issuer) that may affect, restrict, prevent or delay AmBank Group from: <ul style="list-style-type: none"> (i) converting the Relevant Currency into the Settlement Currency through customary legal channels or

ANNEXURE I PRINCIPAL TERMS OF THE DEED POLL (cont'd)

		transferring within or from any Relevant Country either currency, due to the imposition by such Relevant Country of any controls restricting or prohibiting such conversion or transfer, as the case may be;
	(ii)	converting the Relevant Currency into the Settlement Currency at a rate at least as favourable as the rate for domestic financial institutions located in any Relevant Country;
	(iii)	transferring the Relevant Currency or Settlement Currency between bank accounts inside any Relevant Country or to a party that is a non-resident of such Relevant Country; or
	(iv)	transferring the Settlement Currency between bank accounts within Malaysia or to any other bank accounts outside Malaysia or to a party that is a non-resident of Malaysia;
Settlement Exchange Rate		the prevailing rate of exchange between the Relevant Currency and the Settlement Currency (expressed as the number of units of the Settlement Currency per unit of the Relevant Currency) on a day which is within eight (8) Market Days prior to the Settlement Date, based on the rates prescribed by such relevant financial institution or body as determined by the Issuer and as specified in the relevant Term Sheet;
Special Resolution		a resolution passed at a meeting of Holders or Holders of a Series of Structured Warrants duly convened and held and carried by a majority consisting of at least seventy five percent (75%) of the votes cast upon a show of hands or, if a poll is duly demanded, by a majority consisting of at least seventy five percent (75%) of the votes cast on a poll;
Structured Certificate	Warrant	the certificate of each Series of Structured Warrants issued or to be issued in respect of the Structured Warrants in or substantially in the form set out in the First Schedule by the Issuer to Bursa Depository or its nominee company as the same may from time to time be modified in accordance with this Deed Poll;
Structured Registrar	Warrants	Tricor Investor & Issuing House Services Sdn Bhd (Company No. 197101000970 (11324-H)), a company incorporated in Malaysia with its registered office and business office at Unit 32-01, Level 32, Tower A, Vertical Business Suite Avenue 3, Bangsar South, No 8, Jalan Kerinchi, 59200 Kuala Lumpur, or any such person, firm or company as for the time being appointed by the Issuer to whom the Exercise Form is to be delivered;
Take-over Offer		an offer made to acquire all or part of the voting equities in the Underlying Company made pursuant to the Rules on Take-Overs, Mergers and Compulsory Acquisitions, its amendment or re-enactment, or such corresponding provisions in the relevant country which the Underlying Equity(ies) is(are) listed and quoted;
Take-over Offer Period		a period from the date of a notice of a Take-over Offer has been served on the Underlying Company to the close of acceptance of the Take-over Offer;
Term Sheet		the document containing the specific terms and conditions and information on a specific Series of Structured Warrants, to be issued by the Issuer from time to time and which shall be supplemental to and

ANNEXURE I PRINCIPAL TERMS OF THE DEED POLL (cont'd)

	should be read in conjunction with this Deed Poll and the Base Prospectus;
Underlying Company(ies)	in relation to a Series of Structured Warrants, the company(ies) or corporation(s) that has(have) issued the Underlying Equity(ies);
Underlying Equity(ies)	in relation to a Series of Structured Warrants, the equity or equities making up the basket of equities, as the case may be, which is(are) the subject of the Series of Structured Warrants. Such equity(ies) is(are) listed and quoted on Bursa Securities and/or Securities Exchange outside Malaysia which is a member of the World Federation of Exchanges or is approved by Bursa Securities and as specified in the relevant Term Sheet;
Underlying ETF	in relation to a Series of Structured Warrants, the exchange-traded fund which is the subject of the Series of Structured Warrants. Such exchange-traded fund is listed and quoted on Bursa Securities and/or Securities Exchange outside Malaysia which is a member of the World Federation of Exchanges or is approved by Bursa Securities and as specified in the relevant Term Sheet;
Underlying Index	in relation to a Series of Structured Warrants, the index which is the subject of the Series of Structured Warrants. Such index shall be based on Bursa Securities and/or Securities Exchange outside Malaysia which is approved by Bursa Securities and as specified in the relevant Term Sheet;
Underlying Index Sponsor	in relation to a Series of Structured Warrants, the index sponsor that compiles and publishes the Underlying Index and which is specified in the relevant Term Sheet;
unit	means one (1) undivided share in the Underlying ETF;
Valuation Date	Each Market Day on which valuation will be carried out; and
VWAP	arithmetic mean of daily volume weighted average market price; and
Warrant Agency Agreement	the warrant agency agreement dated 2 May 2018 entered into between the Issuer and the Structured Warrants Registrar in relation to the Structured Warrants, as may be amended, modified or supplemented from time to time.

(the remainder of this page is intentionally left blank)

PART 1

CONDITIONS OF THE CASH-SETTLED SINGLE EQUITY CALL OR PUT WARRANTS

1 General, Nature, Form, Transfer, Administration and Status of Structured Warrants

- 1.1 The Structured Warrants comprise **American or European style non-collateralised cash-settled call or put warrants over a single equity** to be issued from time to time by the Issuer through the Base Prospectus and subject to, and with the benefit of the Deed Poll referred to on the face of the Structured Warrant Certificate and these Conditions. The Exercise Rights entitle the Holder of each Structured Warrant for each Series of Structured Warrants issued or to be issued, subject to the Deed Poll and in accordance with these Conditions, upon valid exercise thereof, to the Cash Settlement Amount calculated in accordance with Condition 2. Certain statements in these Conditions are summaries of and are subject to the detailed provisions of the Deed Poll and in the event of any inconsistency between a provision contained in these Conditions and a provision contained in the Deed Poll, the provisions in the Deed Poll shall prevail. The Issuer has entered into a Warrant Agency Agreement with the Structured Warrants Registrar. Copies of the Deed Poll and the Warrant Agency Agreement are available for inspection at the registered office of the Issuer, being at the date hereof at 22nd Floor, Bangunan AmBank Group, No. 55 Jalan Raja Chulan, 50200 Kuala Lumpur, Malaysia. The Holders for the time being of the Structured Warrants and whose names appear on the Record of Depositors are all entitled to the benefit of, bound by, and deemed to have notice of, all the provisions of the Deed Poll and the Warrant Agency Agreement. Further, each Holder acknowledges it has, where necessary, consulted its stockbroker, solicitor or other adviser before investing in the Structured Warrants and none of the Issuer or its directors or employees may be construed as investment adviser or agent of, or owe any fiduciary duty to the Holder. **For the purposes of this Part 1, the term "Structured Warrants" shall refer to the American or European style non-collateralised cash-settled call or put warrants over a single equity.**
- 1.2 Subject to the Central Depositories Act, the Rules of Bursa Depository, the Deed Poll, the relevant applicable rules and regulations and these Conditions:
- (a) each Structured Warrant is an option which confers on the Holder the Exercise Rights which require the Issuer to pay the Cash Settlement Amount to the Holder in accordance with these Conditions; and
 - (b) the Structured Warrants are issued in registered form, serially numbered and are a Prescribed Security to be admitted to the Official List. The Structured Warrants are represented by a global/jumbo certificate issued to Bursa Depository or its nominee who holds the same as bare trustee on behalf of the Holders, and deposited with Bursa Depository in or substantially in the form set out in the First Schedule to the Deed Poll as the same may from time to time be modified in accordance with the Deed Poll.
- 1.3 Subject to all information provided by the subscriber for the Structured Warrants to the Issuer being complete and consistent with the records of Bursa Depository, the Issuer shall within seven (7) Market Days from the date of allotment of the Structured Warrants, cause and procure the Structured Warrants Registrar to notify Bursa Depository of the names of the Holders together with such particulars as may be required by Bursa Depository for the purpose of making appropriate entries in the Securities Account of the respective Holder, request Bursa Depository to credit the Securities Account of the Holders with the applicable Structured Warrants and shall deliver to Bursa Depository the Structured Warrant Certificate registered in the name of Bursa Depository or its nominee company in such manner as may be prescribed by the Rules of Bursa Depository or agreed with Bursa Depository. If, at any time, the information provided by the Holders for the Structured Warrants is incorrect or inaccurate or inconsistent with the records of Bursa Depository, the Issuer reserves the right and without any obligation whatsoever to the Holders, to accept, reject or otherwise deal with the Structured Warrants in such manner as it reasonably deems fit in the circumstances. The Holders are not entitled to any physical warrant certificates.
- 1.4 Subject to the provisions of the Central Depositories Act and the Rules of Bursa Depository, the registration and subsequent administration of Structured Warrants shall be in the manner set forth

ANNEXURE I **PRINCIPAL TERMS OF THE DEED POLL** (cont'd)

in the Deed Poll and the Warrant Agency Agreement. It is hereby acknowledged that the Issuer shall be entitled to appoint registrars for the registration and administration of the Structured Warrants. The Issuer hereby confirms that it shall/has appointed the Structured Warrants Registrar for the purpose stipulated hereof, who shall perform such duties as required by the Issuer under the Deed Poll.

- 1.5 The Holders may transfer the Structured Warrants in the manner prescribed under the Central Depositories Act and the Rules of Bursa Depository. Subject to the provisions of the Central Depositories Act and the Rules of Bursa Depository, the Structured Warrants shall be freely transferable but the trading of the Structured Warrants must be in the same board lot applicable to the trading of the Underlying Equity or any other number of securities or in such odd lots as permitted by the SC and/or Bursa Securities. Where the board lot of the Underlying Equity is more than one hundred (100) equities per board lot, the Structured Warrants may be issued in board lots of one hundred (100) warrants.
- 1.6 The Structured Warrants and the settlement obligation of the Issuer in respect of the Structured Warrants represent general and unsecured contractual obligations of the Issuer and of no other person which rank, and shall rank, equally among themselves and without preference in all respects, subject to such exceptions as may from time to time exist under applicable law or the Deed Poll, with the other existing and future unsecured and unsubordinated obligations of the Issuer.
- 1.7 The Structured Warrants do not confer on the Holders any right to acquire or dispose of equities or other securities, including the Underlying Equity and the Issuer is not under any obligation whatsoever to purchase, hold or deliver such equities or other securities, or any rights and benefits attaching thereto.
- 1.8 The Holders are entitled to the Cash Settlement Amount in accordance with Condition 2.

2 Exercise of the Structured Warrants**2.1 American style Structured Warrants**

- 2.1.1 The Structured Warrants may be exercised in the manner set out in Condition 2.1.2 at any time from the date of issue up to the Expiry Date. In the event the date whereby the Exercise Form is delivered is not a Market Day, then it shall be deemed to be exercised on the next following Market Day.
- 2.1.2 In order to invoke the Exercise Rights, within the Exercise Period a Holder must complete and sign the Exercise Form (which shall be made available by the Structured Warrants Registrar in any manner as may be stipulated by Bursa Securities or such other relevant authority) and deliver the same on a Market Day between 9.00 a.m. to 5.00 p.m. to the Structured Warrants Registrar who shall acknowledge receipt by stamping the date and time of receipt on the Exercise Form in respect of which the Structured Warrants are being exercised.

Provided always that:

- (a) in every case compliance must also be made with the requirements set out in the Exercise Form and other prevailing statutory requirements for the time being applicable;
- (b) the Holder shall, if so required by the Structured Warrants Registrar, furnish such evidence, if any, as the Structured Warrants Registrar or the directors of the Issuer may require to determine the due execution of the Exercise Form by or on behalf of the Holder exercising the same. Once a valid Exercise Form is duly delivered by the Holder to the Structured Warrants Registrar, the exercise of such Exercise Rights shall be irrevocable save with the consent of the directors of the Issuer; and
- (c) where the Holder does not comply with the procedures or restrictions or conditions relating to the exercise of the Structured Warrants, the Exercise Form and any

ANNEXURE I **PRINCIPAL TERMS OF THE DEED POLL** (cont'd)

documents received shall be returned to such Holder by ordinary post to the Holder's address recorded in the Record of Depositors at the risk of the Holder.

- 2.1.3 Subject to notification by the Structured Warrants Registrar of fulfilment of the preconditions by the Holder to validly exercise the Structured Warrants as set out in Condition 2.1.2 within three (3) Market Days from the Exercise Date and the absence of a Settlement Disruption Event, the Issuer shall, within seven (7) Market Days from the Exercise Date or such other period as may be prescribed by Bursa Securities or such other relevant authority, pay to the relevant Holder the Cash Settlement Amount calculated as set out below less Exercise Expenses, if any.

For call warrants:

$$\text{Cash Settlement Amount} = \text{Number of Structured Warrants} \times (\text{Closing Price}^{(1)} - \text{Exercise Price}^{(2)}) \times \frac{1}{\text{Exercise Ratio}^{(2)}} \times \text{Settlement Exchange Rate (if applicable)}$$

For put warrants:

$$\text{Cash Settlement Amount} = \text{Number of Structured Warrants} \times (\text{Exercise Price}^{(2)} - \text{Closing Price}^{(1)}) \times \frac{1}{\text{Exercise Ratio}^{(2)}} \times \text{Settlement Exchange Rate (if applicable)}$$

- (1) The Closing Price shall be calculated by reference to either:

- (a) In the event a valid Exercise Form is received in accordance with Condition 2.1.2 by the Structured Warrants Registrar:

- (i) before 12.30 p.m. on any Market Day other than on the Expiry Date, the exercise of the Structured Warrants shall be deemed to have been made on that Market Day and in such instance the Market Day of receipt of the Exercise Form shall be the Exercise Date and the Valuation Date and the Closing Price shall be the closing price of the Underlying Equity on such Valuation Date; or
- (ii) on or after 12.30 p.m. on any Market Day other than on the Expiry Date, the exercise of the Structured Warrants shall be deemed to have been made on the Market Day immediately following the Market Day of receipt of the Exercise Form and in such instance the Market Day immediately following the Market Day of receipt of the Exercise Form shall be the Exercise Date and the Valuation Date and the Closing Price shall be the closing price of the Underlying Equity on such Valuation Date. For the avoidance of doubt, if a valid Exercise Form is received on or after 12.30 p.m. on a Market Day immediately preceding the Expiry Date, the exercise of the Structured Warrants shall be deemed to have been made on the Expiry Date and in such instance the Closing Price shall be the Expiry Date Closing Price (as defined below) of the Underlying Equity; or
- (iii) on the Expiry Date, the Closing Price shall be the Expiry Date Closing Price (as defined below) of the Underlying Equity,

and as specified in the relevant Term Sheet and subject to the Market Disruption Event provision below.

If the Exercise Date falls within the Take-over Offer Period or the Compulsory Acquisition Period, the Closing Price shall be (i) as calculated above; or (ii) the announced price for the Take-over Offer, whichever is lower (for call warrants) or higher (for put warrants), as the case may be.

If the Underlying Equity is suspended from trading as a result of the Take-over Offer or the Compulsory Acquisition, and the Structured Warrants is only exercised subsequently, the Closing Price shall be the last quoted price of such Underlying Equity immediately before the suspension (subject to the Market Disruption Event provision below) or the announced price for the Take-over Offer, whichever is lower (for call warrants) or higher (for put warrants), as the case may be.

For the avoidance of doubt, in the event the Underlying Equity is delisted, the Closing Price shall be determined in accordance with Condition 10.

If the Exercise Date falls on a Market Day when the Underlying Equity is suspended from trading for any other reason, the Closing Price shall be the last quoted price of such Underlying Equity immediately before the suspension (subject to the Market Disruption Event provision below).

- (b) In the event of any exercise of the Structured Warrants on the Expiry Date, the Closing Price shall be calculated by reference to either:
- (i) the average VWAP of the Underlying Equity (subject to any adjustment as may be necessary to reflect any capitalisation, rights issue, distribution or others) for the five (5) Market Days prior to and including the Market Day immediately before the Expiry Date; or
 - (ii) the average closing price of the Underlying Equity (subject to any adjustment as may be necessary to reflect any capitalisation, rights issue, distribution or others) for the five (5) Market Days prior to and including the Market Day immediately before the Expiry Date; or
 - (iii) the closing price of the Underlying Equity on the Market Day immediately before the Expiry Date,

and as specified in the relevant Term Sheet ("**Expiry Date Closing Price**") and subject to the Market Disruption Event and other provisions herein.

If the Expiry Date falls within the Take-over Offer Period or the Compulsory Acquisition Period, the Expiry Date Closing Price shall be (i) as calculated above; or (ii) the announced price for the Take-over Offer, whichever is lower (for call warrants) or higher (for put warrants), as the case may be.

If the Expiry Date falls on a Market Day when the Underlying Equity is suspended from trading as a result of the Take-over Offer or Compulsory Acquisition, the Expiry Date Closing Price shall be the last quoted price of such Underlying Equity immediately before the suspension (subject to the Market Disruption Event provision below) or the announced price for the Take-over Offer, whichever is lower (for call warrants) or higher (for put warrants), as the case may be.

For the avoidance of doubt, in the event the Underlying Equity is delisted, the Expiry Date Closing Price shall be determined in accordance with Condition 10.

- (c) If a Market Disruption Event, or a public holiday unexpected by the Issuer occurs on any of the five (5) Market Days described in sub-Conditions (1)(b)(i) or (1)(b)(ii) above, the valuation period applicable and the Closing Price shall be as determined by the Issuer in such manner as it reasonably deems fit.

In any other cases where there is a single Valuation Date, if there is a Market Disruption Event on the Valuation Date, the Valuation Date shall be the next following Market Day after the Market Disruption Event. If the

ANNEXURE I **PRINCIPAL TERMS OF THE DEED POLL** (cont'd)

Market Disruption Event continues to occur up to the eighth (8th) Business Day following the original Valuation Date, then the Valuation Date shall be:

- (i) that eighth (8th) Business Day; and
- (ii) the Issuer shall determine as it reasonably deems fit and on the basis of the Issuer's good faith estimate the reference price and/or the exchange rate (if applicable) for that Valuation Date by determining the price of the Underlying Equity and/or the exchange rate (if applicable) based on the prevailing market conditions and other factors as the Issuer may consider relevant.

- (2) The Exercise Price and/or Exercise Ratio shall be subject to such adjustments as may be necessary as provided in Condition 6.

2.1.4 In the event that the Cash Settlement Amount after deduction of the Exercise Expenses, if any, is equal to or less than zero, the Issuer shall not be obliged to make any payment to the relevant Holder, and the Structured Warrants exercised shall thereafter become void and cease to have the Exercise Rights and the Issuer's obligations in respect of the Structured Warrants shall terminate absolutely. For the avoidance of doubt, the Holder shall not be required to pay or top-up the Exercise Expenses, if any, as the case may be, where the Cash Settlement Amount after deduction of the Exercise Expenses, if any, is less than zero.

2.1.5 If the Structured Warrants are not earlier exercised, the Structured Warrants shall be deemed automatically exercised at 5.00 p.m. on the Expiry Date, without the Holders having to deliver a valid Exercise Form to the Structured Warrants Registrar and without notice of automatic exercise being given by the Issuer to the Holders.

2.1.6 Upon automatic exercise of the Structured Warrants on the Expiry Date in accordance with Condition 2.1.5, if the Cash Settlement Amount after deduction of the Exercise Expenses, if any:

- (a) is greater than zero, in the absence of a Settlement Disruption Event, payment shall be made by the Issuer to the relevant Holders within seven (7) Market Days from the Expiry Date and the Issuer's obligations in respect of the Structured Warrants, shall terminate absolutely; or
- (b) is equal to or less than zero, the Structured Warrants shall terminate and cease to be valid and the Issuer's obligations in respect of the Structured Warrants, shall terminate absolutely. For the avoidance of doubt, the Holder shall not be required to pay or top-up the Exercise Expenses, if any, as the case may be, where the Cash Settlement Amount after deduction of the Exercise Expenses, if any, is less than zero.

2.2 European style Structured Warrants

2.2.1 The Structured Warrants shall be automatically exercised at 5.00 p.m. on the Expiry Date if the Cash Settlement Amount calculated in accordance with Condition 2.2.2 after deduction of the Exercise Expenses, if any, is greater than zero (without the Holders having to deliver a valid Exercise Form and without notice of automatic exercise being given by the Issuer to the Holders). If the Expiry Date is not a Market Day then it shall be deemed to be exercised on the next following Market Day. The Structured Warrants will automatically terminate and cease to be valid at 5.00 p.m. on the Expiry Date if the Cash Settlement Amount after deduction of the Exercise Expenses, if any, is equal to or less than zero and the Issuer's obligations in respect of the Structured Warrants shall terminate absolutely. For the avoidance of doubt, the Holder shall not be required to pay or top-up the Exercise Expenses, if any, as the case may be, where the Cash Settlement Amount after deduction of the Exercise Expenses, if any, is less than zero.

2.2.2 The Issuer shall in the absence of a Settlement Disruption Event, within seven (7) Market Days from the Expiry Date or such other period as may be prescribed by Bursa Securities

ANNEXURE I PRINCIPAL TERMS OF THE DEED POLL (cont'd)

or such other relevant authority, pay to the relevant Holder, the Cash Settlement Amount calculated as set out below less Exercise Expenses, if any.

For call warrants:

$$\text{Cash Settlement Amount} = \text{Number of Structured Warrants} \times \left(\frac{\text{Closing Price}^{(1)} - \text{Exercise Price}^{(2)}}{\text{Exercise Ratio}^{(2)}} \right) \times \frac{1}{\text{Exercise Ratio}^{(2)}} \times \text{Settlement Exchange Rate (if applicable)}$$

For put warrants:

$$\text{Cash Settlement Amount} = \text{Number of Structured Warrants} \times \left(\frac{\text{Exercise Price}^{(2)} - \text{Closing Price}^{(1)}}{\text{Exercise Ratio}^{(2)}} \right) \times \frac{1}{\text{Exercise Ratio}^{(2)}} \times \text{Settlement Exchange Rate (if applicable)}$$

(1) (a) The Closing Price on the Expiry Date shall be calculated by reference to either:

- (i) the average VWAP of the Underlying Equity (subject to any adjustment as may be necessary to reflect any capitalisation, rights issue, distribution or others) for the five (5) Market Days prior to and including the Market Day immediately before the Expiry Date; or
- (ii) the average closing price of the Underlying Equity (subject to any adjustment as may be necessary to reflect any capitalisation, rights issue, distribution or others) for the five (5) Market Days prior to and including the Market Day immediately before the Expiry Date; or
- (iii) the closing price of the Underlying Equity on the Market Day immediately before the Expiry Date,

and as specified in the relevant Term Sheet and subject to the Market Disruption Event and other provisions herein.

If the Expiry Date falls within the Take Over Offer Period or the Compulsory Acquisition Period, the Closing Price shall be as calculated above or the announced price for the Take-over Offer, whichever is lower (for call warrants) or higher (for put warrants), as the case may be.

If the Expiry Date falls on a Market Day when the Underlying Equity is suspended from trading as a result of the Take-over Offer or the Compulsory Acquisition, the Closing Price shall be the last quoted price of such Underlying Equity immediately before the suspension (subject to the Market Disruption Event provision below), or the announced price for the Take-over Offer, whichever is lower (for call warrants) or higher (for put warrants), as the case may be.

For the avoidance of doubt, in the event the Underlying Equity is delisted, the Closing Price shall be determined in accordance with Condition 10 below.

- (b) If a Market Disruption Event, or a public holiday unexpected by the Issuer occurs on any of the five (5) Market Days described in sub-Conditions (1)(a)(i) or (1)(a)(ii) above, the valuation period applicable and the Closing Price shall be as determined by the Issuer in such manner as it reasonably deems fit.

In any other cases where there is a single Valuation Date, if there is a Market Disruption Event on the Valuation Date, the Valuation Date shall be the next following Market Day after the Market Disruption Event. If the Market

ANNEXURE I**PRINCIPAL TERMS OF THE DEED POLL (cont'd)**

Disruption Event continues to occur up to the eighth (8th) Business Day following the original Valuation Date, then the Valuation Date shall be:

- (i) that eighth (8th) Business Day; and
- (ii) the Issuer shall determine as it reasonably deems fit and on the basis of the Issuer's good faith estimate the reference price and/or the exchange rate (if applicable) for that Valuation Date by determining the price of the Underlying Equity and/or the exchange rate (if applicable) based on the prevailing market conditions and other factors as the Issuer may consider relevant.

- (2) The Exercise Price and/or Exercise Ratio shall be subject to such adjustments as may be necessary as provided in Condition 6.

2.2.3 In the event that the Cash Settlement Amount after deduction of the Exercise Expenses, if any, is equal to or less than zero on the Expiry Date, the Structured Warrants shall terminate on the Expiry Date and cease to be valid and the Issuer's obligations in respect of the Structured Warrants shall terminate absolutely. For the avoidance of doubt, the Holder shall not be required to pay or top-up the Exercise Expenses, if any, as the case may be, where the Cash Settlement Amount after deduction of the Exercise Expenses, if any, is less than zero.

- 2.3 (a) The Cash Settlement Amount less the Exercise Expenses, if any, shall be made by way of cheque drawn in favour of the Holder to be delivered by ordinary post to the Holder's address last recorded in the Record of Depositors at the Holder's own risk or by way of electronic transfer of funds to the bank account of the Holder, the details of which are provided by Bursa Depository to the Issuer at the request of the Issuer. Where the Issuer makes a payment to a Holder pursuant to the terms of Conditions 2.1 or 2.2, the amount of such payment arising from the exercise of the Structured Warrants shall be final and conclusive and the Issuer shall be discharged from its obligation upon making such payment thereof in accordance with these Conditions.
 - (b) The Cash Settlement Amount less the Exercise Expenses, if any, shall be calculated and be payable in the Settlement Currency and rounded down to the nearest two (2) decimal points. All determinations made by the Issuer pursuant to Conditions 2.1 or 2.2 shall be final and conclusive and binding on the Holders.
 - (c) The Holder is to bear all Exercise Expenses, if any, in relation to the exercise of the Structured Warrants and on exercise of the Structured Warrants, the Issuer shall be irrevocably authorised by the Holder to deduct all Exercise Expenses, if any, from the Cash Settlement Amount.
 - (d) If as a result of a Settlement Disruption Event, it is not possible for the Issuer to make payment on the original Settlement Date, the Issuer shall use its reasonable endeavours to procure payment as soon as practicable after the original Settlement Date. The Issuer shall not be liable to the Holder for any interest in respect of the amount due or any loss or damage that such Holder may suffer as a result of the existence of the Settlement Disruption Event.
- 2.4 The Issuer shall not allow the Holder to exercise the Exercise Rights unless the Structured Warrants are or have been designated as "free securities" in accordance with the Rules of Bursa Depository.
- 2.5 The Issuer declares that approval shall be sought from Bursa Securities for the admission of the Structured Warrants to the Official List and for the listing of and quotation for the Structured Warrants on Bursa Securities.
- 2.6 All questions as to the validity, form, eligibility (including time of receipt) and acceptance of Exercise Form shall be resolved by the Structured Warrants Registrar in a manner as it reasonably deems fit, whose determination shall be final and binding on the Issuer and the Holder. The Structured Warrants Registrar is entitled to reject any Exercise Form that is not in proper form or the

ANNEXURE I**PRINCIPAL TERMS OF THE DEED POLL (cont'd)**

acceptance of which may, in the view of counsel for the Structured Warrants Registrar be unlawful. The Structured Warrants Registrar also reserves the right, subject to applicable law, to waive any irregularities. The interpretation of the Structured Warrants Registrar of the terms and conditions of exercise of the Structured Warrants shall be final and binding on the Issuer and the Holder. Unless waived, any irregularities in connection with the Exercise Form must be rectified by such time, as the Structured Warrants Registrar shall determine. The Structured Warrants Registrar shall not be under any duty to give notification of any irregularities in such Exercise Form and shall not incur liabilities for failure to give such notification. The Exercise Form shall not be considered to have been validly delivered until such irregularities have been rectified and waived.

- 2.7 The initial Structured Warrants Registrar and its specified offices are stated in the Deed Poll. The Issuer reserves the right at any time to terminate the appointment of the Structured Warrants Registrar. Prior written notice of any termination, appointment of Structured Warrants Registrar, resignation of the Structured Warrants Registrar or any changes in any of the specified offices of the relevant Structured Warrants Registrar shall be given to the Holders in accordance with Condition 15 and such prior notice shall be given to the Holders not more than sixty (60) days and less than thirty (30) days of such termination, appointment, resignation or change.
- 2.8 In respect of each Structured Warrant in which Exercise Rights have been exercised, the Issuer shall instruct or procure the Structured Warrants Registrar to instruct Bursa Depository, to debit the appropriate number of Structured Warrants in respect of which Exercise Rights have been exercised from the Securities Account of such Holder. The Issuer shall be entitled at any time on or after the Expiry Date, to demand that Bursa Depository deliver to the Issuer the Structured Warrant Certificates and thereafter cancel or cause the cancellation of the Structured Warrant Certificates.
- 2.9 The Structured Warrants subject to the Exercise Rights which have been exercised in accordance with the Deed Poll shall cease to exist and all obligations of the Issuer in respect of those Structured Warrants shall terminate absolutely following payment of the amount (if any) referred to in this Condition 2.

3 Exercise Rights and Suspension

- 3.1 Upon and subject to the provisions of the Central Depositories Act, the Rules of Bursa Depository and the Deed Poll, the Holder whose name as stated in the Record of Depositors shall have the right at any time during the Exercise Period to invoke its Exercise Rights at the Exercise Price subject to adjustments in accordance with Condition 6.
- 3.2 The Structured Warrants shall, subject to any directions, order or notice from any relevant regulatory authority and any request for suspension by the Issuer which is not rejected by any such relevant regulatory authority, continue to be traded notwithstanding that the trading of the Underlying Equity may have been suspended. Any suspension in the trading of the Underlying Equity or the Structured Warrants shall not preclude the Holder from exercising the Exercise Rights.
- 3.3 The Issuer shall notify the Holders of the Expiry Date at least one (1) month prior to the Expiry Date or such other period as may be specified by the relevant authority. Such notice shall be given in accordance with Condition 15 stating the Expiry Date and treatment of the Structured Warrants which are not exercised.

4 Deposit and Forfeiture of Unclaimed Amount

- 4.1 In the event that the Issuer pays the Cash Settlement Amount to any Holder under Condition 2 and such Holder does not present the cheque for payment within six (6) months from the date of the cheque, the Issuer shall at any time thereafter deal with the said monies in accordance and in compliance with, the requirements of the Unclaimed Moneys Act 1965 (Act 370) (revised 1989) of Malaysia.

ANNEXURE I **PRINCIPAL TERMS OF THE DEED POLL** (cont'd)**5 Designation of Structured Warrants set out in the Exercise Form**

5.1 Subject to the approval of Bursa Depository and/or other relevant authority, the Issuer reserves all rights to instruct Bursa Depository and/or other relevant authority to designate the Structured Warrants held in the relevant Securities Account of a Holder which the Holder has purportedly exercised by submitting an Exercise Form to the Issuer and/or the Structured Warrants Registrar, in order for Bursa Depository and/or the relevant authority to prohibit the Holder from trading on the exchange the designated Structured Warrants after the aforesaid exercise. The Issuer's right to instruct Bursa Depository and/or the relevant authority shall be independent of whether the exercise is valid or otherwise, provided that the amount of Structured Warrants so designated by Bursa Depository and/or the relevant authority do not exceed the amount set out in such Exercise Form.

6 Adjustment of Exercise Price and/or Exercise Ratio

6.1 Adjustments

Subject to the Conditions as hereinafter provided and the Deed Poll, the Exercise Price and/or the Exercise Ratio for the relevant Structured Warrant shall from time to time be adjusted in accordance with the following provisions:

(a) Bonus Issue

If and whenever the Underlying Company of the relevant Structured Warrants shall make an issue of new equities ("**Equities**") credited as fully paid-up to the holders of Equities generally by way of capitalisation of profits or reserves (other than pursuant to a scrip dividend or similar scheme for the time being operated by the Underlying Company or otherwise in lieu of a cash dividend and without any payment or other consideration being made or given by such holders) ("**Bonus Issue**"), the Exercise Price and/or Exercise Ratio shall be adjusted on the Market Day immediately following the last day on which an instrument of transfer could be lodged so that the transferee of the Equities would qualify for the Bonus Issue in accordance with the following formula:

$$(i) \quad \text{Adjusted Exercise Ratio} = \frac{E}{(1 + N)}$$

$$(ii) \quad \text{Adjusted Exercise Price} = \frac{X}{(1 + N)}$$

Whereby in respect of this Condition 6.1(a)(i) and (ii):

X = Existing Exercise Price immediately prior to the Bonus Issue

N = The number of additional Equities (whether a whole or a fraction) received by a holder of existing Equities for each Equity (of the relevant Underlying Company) held prior to the Bonus Issue

E = Existing Exercise Ratio immediately prior to the Bonus Issue

Alternatively, the Issuer may also, in good faith, make a corresponding adjustment to the Exercise Ratio and/or Exercise Price as the Issuer determines appropriate to account for the dilutive effect of the Bonus Issue.

On any such adjustment, the resultant Exercise Ratio and/or Exercise Price shall be rounded to the nearest four (4) decimal points of the Relevant Currency and all such adjustment made by the Issuer pursuant to this Condition shall be deemed as final and conclusive save for any manifest error.

(b) Rights Issue

If and whenever an Underlying Company of the relevant Structured Warrants shall, by way of Rights (as defined below), offer new Equities for subscription at a fixed subscription price

ANNEXURE I**PRINCIPAL TERMS OF THE DEED POLL** (cont'd)

("Rights Issue Price") to the holders of existing Equities pro rata to the holders' existing holdings ("Rights Issue"), the Exercise Price and/or the Exercise Ratio shall be adjusted on the Market Day immediately following the last day on which an instrument of transfer of such Equities could be lodged so that the transferee of the Equity(ies) would qualify for the Rights Issue in accordance with the following formula:

(i) Adjusted Exercise Ratio =

$$\frac{1 + (R/S) \times M}{1 + M} \times E$$

(ii) Adjusted Exercise Price =

$$\frac{1 + (R/S) \times M}{1 + M} \times X$$

Whereby, in respect of this Condition 6.1(b)(i) and (ii):

- R = Subscription price per Share of the Underlying Company of the relevant Structured Warrants under the Rights Issue.
- S = Cum-rights share price being the last traded price of an existing Equity of the Underlying Company of the relevant Structured Warrants making the Rights Issue on the last Market Day on which the Equities (of the Underlying Company of the relevant Structured Warrants making the Rights Issue) are traded on a cum-rights basis.
- M = Number of new Equities (whether a whole or fraction) per existing equity of the Underlying Company of the relevant Structured Warrants making the Rights Issue each holder thereof is entitled to subscribe.
- X = Existing Exercise Price immediately prior to the Rights Issue.
- E = Existing Exercise Ratio immediately prior to the Rights Issue.

Alternatively, the Issuer may also, in good faith, make a corresponding adjustment to the Exercise Ratio and/or Exercise Price as the Issuer determines appropriate to account for the dilutive effect of the Rights Issue.

On any such adjustment, the resultant Exercise Ratio and/or Exercise Price shall be rounded to the nearest four (4) decimal points of the Relevant Currency and all such adjustment made by the Issuer pursuant to this Condition shall be deemed as final and conclusive save for any manifest error.

For the purposes hereof, "**Rights**" means the Right(s) attached to each existing Equity or needed to acquire one new Equity (as the case may be) which are given to the holders of existing Equities to subscribe for new Equities at a fixed subscription price pursuant to the Rights Issue (whether by the exercise of one Right, a part of a Right or an aggregate number of Rights).

(c) Subdivision or Consolidation

If and whenever the Underlying Company of the relevant Structured Warrants shall subdivide its Equities or any class of its outstanding share capital comprising the Equities into a greater number of Equities (a "**Subdivision**"), or consolidate the Equities or any class of its outstanding share capital comprising the Equities into a smaller number of Equities (a "**Consolidation**"), the Exercise Price and/or the Exercise Ratio shall be adjusted on the Market Day on which the relevant Subdivision or Consolidation shall have taken effect in accordance with the following formula:

ANNEXURE I **PRINCIPAL TERMS OF THE DEED POLL** (cont'd)

(i) Adjusted Exercise Ratio =

$$\frac{E \times P}{N}$$

(ii) Adjusted Exercise Price =

$$\frac{X \times P}{N}$$

Whereby, in respect of this Condition 6.1(c)(i) and (ii):

- X = Existing Exercise Price immediately prior to the Subdivision or Consolidation.
- N = Revised number of issued shares after the Subdivision or Consolidation.
- P = Existing number of issued shares immediately prior to the Subdivision or Consolidation.
- E = Existing Exercise Ratio immediately prior to the Subdivision or Consolidation.

Alternatively, the Issuer may also, in good faith, make a corresponding adjustment to the Exercise Ratio and/or Exercise Price as the Issuer determines appropriate to account for the dilutive or consolidative effect of the Subdivision or Consolidation.

On any such adjustment, the resultant Exercise Ratio and/or Exercise Price shall be rounded to the nearest four (4) decimal points of the Relevant Currency and all such adjustment made by the Issuer pursuant to this Condition shall be deemed as final and conclusive save for any manifest error.

(d) Capital Repayment

Should the Underlying Company of the relevant Structured Warrants undertake a capital repayment in cash whether in the form of special dividend or not (pursuant to Section 115 of the Companies Act 2016 or such other corresponding provision in the Relevant Country in which the Underlying Equity is listed and quoted) during the tenure of the Structured Warrants, the Exercise Price and/or the Exercise Ratio of the Structured Warrants shall be adjusted on the Market Day following the last day on which an instrument of transfer is lodged to enable the transferee of the Equities to qualify for the capital repayment by the amount of the capital repayment, net of taxation, if any.

The Exercise Ratio and Exercise Price for the Structured Warrants shall be adjusted in accordance with the following formula:

(i) Adjusted Exercise Ratio =

$$E \times \frac{(P - D)}{P}$$

(ii) Adjusted Exercise Price =

$$X \times \frac{(P - D)}{P}$$

Whereby, in respect of this Condition 6.1(d)(i) and (ii):

ANNEXURE I**PRINCIPAL TERMS OF THE DEED POLL (cont'd)**

- P = Closing Price of the Underlying Equity on the last market day on which the Underlying Equity is traded on a cum-entitlement basis.
- D = The capital repayment per one (1) Underlying Equity held.
- X = Existing Exercise Price immediately prior to the capital repayment.
- E = Existing Exercise Ratio immediately prior to the capital repayment.

The Exercise Ratio and/or Exercise Price of the Structured Warrants shall not be adjusted for capital repayment in specie or in the form of other securities, other than for bonus issue and rights issue pursuant to Conditions 6.1(a) and (b).

Alternatively, the Issuer may also, in good faith, make a corresponding adjustment to the Exercise Ratio and/or Exercise Price as the Issuer determines appropriate to account for the effect of the capital repayment.

On any such adjustment, the resultant Exercise Ratio and/or Exercise Price shall be rounded to the nearest four (4) decimal points of the Relevant Currency and all such adjustment made by the Issuer pursuant to this Condition shall be deemed as final and conclusive save for any manifest error.

Notwithstanding the above, if a capital repayment undertaken by the relevant Underlying Company results in a significant change in the business of such Underlying Company or such other circumstances as the Issuer may determine, the Issuer is entitled to terminate the Structured Warrants without prior notice to the Holders. If the Issuer terminates the Structured Warrants, then the Issuer will, if and to the extent permitted by applicable law, pay an amount to each Holder in respect of each Structured Warrant held by such Holder if the Cash Settlement Amount after deduction of the Exercise Expenses, if any, is greater than zero (without the Holder having to deliver a valid Exercise Form). The Cash Settlement Amount shall be determined based on the fair market value of the Structured Warrants (as determined by the Issuer) after taking into account the capital repayment exercise less all Exercise Expenses, if any, as determined by the Issuer in a manner as it reasonably deems fit.

(e) Other adjustments

The Issuer is entitled to make other adjustments as it reasonably believes are appropriate in circumstances where an event or events occur which the Issuer believes (notwithstanding any adjustment previously made by the Issuer) should, in the context of the issue of Structured Warrants and its obligations hereunder, give rise to such adjustment. The Issuer shall make such adjustment generally without considering the individual circumstances of any Holder or the tax or other consequences of such adjustment in any particular jurisdiction.

On any such adjustment, the resultant Exercise Ratio and/or Exercise Price shall be rounded to the nearest four (4) decimal points of the Relevant Currency.

- 6.2 Notwithstanding the foregoing, no adjustments shall be made to the Exercise Ratio and/or Exercise Price if the formulae stated in Condition 6.1(a) to Condition 6.1(e) results in an adjustment which would amount to less than two percent (2%) of the Exercise Ratio and/or Exercise Price being changed.
- 6.3 Any termination of Structured Warrants or adjustment made pursuant to Conditions 6.1 and 6.2 shall be final and binding on the Holders save in the case of manifest error. Notice of such termination, adjustments or amendments shall be given to the Holders as soon as practicable thereafter in accordance with Condition 15 and in any event within five (5) Market Days of such termination or adjustment being made.

ANNEXURE I **PRINCIPAL TERMS OF THE DEED POLL** (cont'd)**7** **Restrictions to Protect Rights of Holders**

- 7.1 As from the date of the issue of the Structured Warrants and for so long as any of the Structured Warrants remain exercisable, the Issuer shall have arrangements in place to ensure, for the benefit of the Holders that it is able to satisfy in full the exercise of all the Structured Warrants for the time being outstanding.

8 **Merger or Consolidation of Underlying Company**

- 8.1 In the event of a merger, amalgamation or reconstruction of the Underlying Company wherein an Underlying Company is to or may merge or consolidate with or into any other corporation (including becoming, by agreement or otherwise, a subsidiary of any corporation or controlled by any person or corporation) (except where the Underlying Company is the surviving corporation in a merger), or is to or may sell or transfer all or substantially all of its assets ("**Restructuring Event**"), the Issuer may in good faith take any of the actions below:

- (a) cancel the Structured Warrants without prior notice to the Holders. If the Structured Warrants are so cancelled, the Issuer shall pay an amount to each Holder, if the Cash Settlement Amount after deduction of the Exercise Expenses, if any, is greater than zero (without the Holder having to deliver a valid Exercise Form). The Cash Settlement Amount shall be determined based on the fair market value of the Underlying Equity (as determined by the Issuer) after taking into account the Restructuring Event less all Exercise Expenses, if any, as determined by the Issuer as it reasonably deems fit; and/or
- (b) amend and determine the appropriate adjustment, if any, to be made to the terms and conditions of the Structured Warrants to account for the Restructuring Event and determine the effective date of that adjustment. After such adjustments (if any), the Structured Warrants shall relate to the number of equities of the corporation(s) resulting from or surviving such Restructuring Event or other securities ("**Substituted Securities**") and/or cash offered in substitution for the affected Underlying Equity of the relevant Structured Warrants to which the holder of such number of Underlying Equity to which the Structured Warrants related immediately before such Restructuring Event would have been entitled upon such Restructuring Event, as the case may be. The Issuer may, but need not, determine the appropriate adjustment by reference to the adjustment in respect of the Restructuring Event made by a Securities Exchange to options on the relevant Underlying Equity traded on that Securities Exchange.

- 8.2 Upon the occurrence of a Restructuring Event, the rights attaching to the Structured Warrants in respect of that Underlying Company may be amended by the Issuer no later than the Market Day preceding the consummation of such Restructuring Event.

- 8.3 The provisions of these Conditions shall apply to such Substituted Securities provided that, any Substituted Securities may, as the Issuer reasonably deems fit, be replaced by an amount in the Relevant Currency equal to the market value or, if no market value is available, fair value, of such Substituted Securities in each case as determined by the Issuer as soon as practicable after such Restructuring Event is effected.

- 8.4 Any cancellation of Structured Warrants or modification of rights made pursuant to Condition 8.1 or 8.2 shall be notified to the Holders as soon as practicable thereafter and in any event within five (5) Market Days from the date of such cancellation or modification in accordance with Condition 15.

9 **Take-over Offer, Compulsory Acquisition or other Forms of Reorganisation in respect of the Underlying Company**

- 9.1 Take-over Offer or Compulsory Acquisition

In the event of the Take-Over Offer or Compulsory Acquisition or any other event having similar effect on the rights of the Holders ("**Other Event**") no cancellation of the relevant Structured Warrants shall be effected and the relevant Structured Warrants shall remain exercisable by the Holder for the remaining tenure of the Exercise Period unless any such Take-Over Offer,

ANNEXURE I PRINCIPAL TERMS OF THE DEED POLL (cont'd)

Compulsory Acquisition or Other Event results in any of the circumstances referred to in Condition 10 or Condition 11, in which event, the relevant provisions of Condition 10 or Condition 11 shall apply.

9.2 Other Forms of Reorganisation

In the event of a scheme of arrangement or any other forms of reorganisation including any scheme of arrangement or reorganisation resulting in the privatisation of the Underlying Company, or the Underlying Company is placed under a judicial management under any applicable laws, the Issuer is entitled to deal with the Structured Warrants in such manner as it reasonably deems fit in the circumstances and with or without any adjustments to the rights attaching to the relevant Structured Warrants.

10 Delisting of the Underlying Equity

10.1 If at any time the Underlying Equity of the Structured Warrants ceases to be listed on Bursa Securities or such other Securities Exchanges or there is an announcement of an intention to cease the listing status of the Underlying Company or the Underlying Equity is suspended from trading on Bursa Securities or such other Securities Exchanges prior to, and in connection with the delisting of the Underlying Equity, the Structured Warrants may if determined by the Issuer be automatically exercised without the Holder having to deliver a valid Exercise Form and without notice of automatic exercise being given by the Issuer to the Holder:

- (a) if the Cash Settlement Amount after deduction of the Exercise Expenses, if any, is greater than zero, the Issuer shall make payment of the Cash Settlement Amount to the relevant Holder; or
- (b) if the Cash Settlement Amount after deduction of the Exercise Expenses, if any, is equal to or less than zero, the Issuer shall not be obliged to make any payment to the relevant Holder and the relevant Structured Warrants shall terminate and cease to be valid and the Issuer's obligations in respect of the Structured Warrants shall terminate absolutely. For the avoidance of doubt, the Holder shall not be required to pay or top-up the Exercise Expenses, if any, as the case may be, where the Cash Settlement Amount after deduction of the Exercise Expenses, if any, is less than zero.

The Closing Price for the calculation of the Cash Settlement Amount (calculated in accordance with Condition 2) shall be the last quoted price of the Underlying Equity immediately before such events or determined in accordance with Condition 2.1.3(1)(b) or 2.2.2, as the case may be, and the Issuer shall not be obliged to make any adjustment to the Exercise Price.

Provided that there is a Market Disruption Event on the date immediately before such events ("**Set Date**"), the Closing Price shall be based on the Market Day immediately preceding the Market Disruption Event. If the preceding Market Day is also affected by the Market Disruption Event, then the Closing Price shall be determined by the Issuer on the Set Date as it reasonably deems fit and on the basis of the Issuer's good faith estimate the reference price and/or the exchange rate (if applicable) for that Set Date by determining the price of the Underlying Equity and/or the exchange rate (if applicable) based on the prevailing market conditions and other factors as the Issuer may consider relevant.

However, in the event the Underlying Equity is suspended or delisted (as the case may be) as a result of the Take-over Offer or the Compulsory Acquisition, the Closing Price for the calculation of the Cash Settlement Amount shall be as calculated above or the announced price for the Take-over Offer, whichever is lower (for call warrants) or higher (for put warrants), as the case may be.

10.2 Subject to the aforesaid, the Issuer may but shall not be obliged to make any adjustment to the terms and conditions of the Structured Warrants and the rights attaching to the Structured Warrants as it shall reasonably consider appropriate to ensure that the interests of the Holders generally are not materially prejudiced as a consequence of such events (without considering the individual circumstances of any Holder or the tax or other consequences that may result in any particular jurisdiction).

ANNEXURE I PRINCIPAL TERMS OF THE DEED POLL (cont'd)**11 Liquidation, Dissolution or Winding-Up of the Underlying Company**

11.1 In the event of a liquidation, dissolution or winding-up of the Underlying Company or the appointment of a liquidator, receiver or administrator or analogous person under any applicable law in respect of the whole or substantially the whole of the Underlying Company's Assets, the Structured Warrants will be automatically exercised without the Holder having to deliver a valid Exercise Form and without notice of automatic exercise being given by the Issuer to the Holder:

- (a) if the Cash Settlement Amount after deduction of the Exercise Expenses, if any, is greater than zero, the Issuer shall make payment of the Cash Settlement Amount to the relevant Holder; or
- (b) if the Cash Settlement Amount after deduction of the Exercise Expenses, if any, is equal to or less than zero, the Issuer shall not be obliged to make any payment to the relevant Holder and the relevant Structured Warrants shall terminate and cease to be valid and the Issuer's obligations in respect of the Structured Warrants shall terminate absolutely. For the avoidance of doubt, the Holder shall not be required to pay or top-up the Exercise Expenses, if any, as the case may be, where the Cash Settlement Amount after deduction of the Exercise Expenses, if any, is less than zero.

The Closing Price for the calculation of the Cash Settlement Amount (calculated in accordance with Condition 2) shall be the closing price of the Underlying Equity on the Market Day immediately before such events or determined in accordance with Condition 2.1.3(1)(b) or 2.2.2, as the case may be, and the Issuer shall not be obliged to make any adjustment to the Exercise Price.

Provided that if there is a Market Disruption Event on the Set Date, the Closing Price shall be based on the Market Day immediately preceding the Market Disruption Event. If the preceding Market Day is also affected by the Market Disruption Event, then the Closing Price shall be determined by the Issuer on the Set Date as it reasonably deems fit and on the basis of the Issuer's good faith estimate the reference price and/or the exchange rate (if applicable) for that Set Date by determining the price of the Underlying Equity and/or the exchange rate (if applicable) based on the prevailing market conditions and other factors as the Issuer may consider relevant.

11.2 Subject to the aforesaid, the Issuer may but shall not be obliged to make any adjustment to the terms and conditions of the Structured Warrants and the rights attaching to the Structured Warrants as it shall reasonably consider appropriate to ensure that the interest of the Holders generally are not materially prejudiced as a consequence of such events (without considering the individual circumstances of any Holder or the tax or other consequences that may result in any particular jurisdiction).

11A Takeover, Merger, Liquidation, Dissolution or Winding-Up of Issuer

11A.1 In the event of a take-over or a scheme of arrangement or any other form of reorganisation undertaken by the Issuer or any other events having similar effects on the rights of the Holders, the Issuer is entitled to deal with the Structured Warrants in such manner as it reasonably deems fit in the circumstances and with or without any adjustments to the rights attaching to the relevant Structured Warrants.

11A.2 In the event of a merger, amalgamation or reconstruction of the Issuer, the corporation, trust or other body into which the Issuer is merged, amalgamated or reconstructed shall assume all the liabilities and the obligations of the Issuer in respect of the Structured Warrants so that the rights of the Holders shall continue to exist and be enforceable to the same extent as provided by the Issuer under the Deed Poll.

11A.3 In the event of a liquidation, dissolution or winding-up of the Issuer or the appointment of a receiver or administrator or analogous person under any applicable law in respect of the whole or substantially the whole of the Issuer's Assets, the Structured Warrants remaining outstanding shall be deemed to be exercised on the Market Day immediately prior to the date of such liquidation, dissolution, winding-up or appointment as follows:

ANNEXURE I PRINCIPAL TERMS OF THE DEED POLL (cont'd)

- (a) All unexercised Structured Warrants shall automatically be exercised without the Holders having to deliver a valid Exercise Form and without notice of automatic exercise being given by the Issuer to the Holders:
- (i) if the Cash Settlement Amount after deduction of the Exercise Expenses, if any, is greater than zero, the Issuer shall make payment of the Cash Settlement Amount to the relevant Holder; or
 - (ii) if the Cash Settlement Amount after deduction of the Exercise Expenses, if any, is equal to or less than zero, the Issuer shall not be obliged to make any payment to the relevant Holder and the relevant Structured Warrants shall terminate and cease to be valid and the Issuer's obligations in respect of the Structured Warrants shall terminate absolutely. For the avoidance of doubt, the Holder shall not be required to pay or top-up the Exercise Expenses, if any, as the case may be, where the Cash Settlement Amount after deduction of the Exercise Expenses, if any, is less than zero.

The closing price of the Underlying Equity on the Market Day immediately before the above events shall form the Closing Price for the calculation of the Cash Settlement Amount.

- (b) Notwithstanding the foregoing, if there is a Market Disruption Event on the Set Date, the Closing Price shall be based on the Market Day immediately preceding the Market Disruption Event. If the preceding Market Day is also affected by the Market Disruption Event, the Closing Price shall be determined by the Issuer on the Set Date as it reasonably deems fit and on the basis of the Issuer's good faith estimate the reference price and/or the exchange rate (if applicable) for that Set Date by determining the price of the Underlying Equity and/or the exchange rate (if applicable) based on the prevailing market conditions and other factors as the Issuer may consider relevant.

12 Replacement of Structured Warrant Certificate

- 12.1 If the Structured Warrant Certificate which has been deposited with Bursa Depository is mutilated, defaced, lost, worn out, stolen or destroyed it shall be replaced by the Issuer at the registered office of the Structured Warrants Registrar on such terms as to evidence and indemnity or otherwise as the Issuer may require. All payment of such costs as may be incurred in connection therewith shall be borne by the Issuer. Mutilated, defaced, lost, worn, stolen or destroyed Structured Warrant Certificates shall be deemed cancelled.

13 Register, Transfer and Transmission

- 13.1 Each Holder registered in the Record of Depositors shall be entitled to all rights, benefits, powers and privileges and be subject to all liabilities, duties and obligations in respect of, or arising from the Structured Warrants, and shall be deemed and treated as the absolute owner of the relevant Structured Warrants, in accordance with the Central Depositories Act and the Rules of Bursa Depository, whether or not the Issuer shall be in default in respect of the Structured Warrants or any of the covenants contained herein and notwithstanding any notice of ownership or writing thereon or notice of any previous loss or theft of any Structured Warrants. The provisions of the Central Depositories Act, the Rules of Bursa Depository and the Issuer's constitution for the time being relating to the registration, transfer and transmission of shares and the fees payable thereon shall apply with necessary modification to the registration, transfer and transmission of the legal ownership of the Structured Warrants, subject always to the provisions of this Condition 13 and Condition 2.
- 13.2 The entries made under the Record of Depositors shall be deemed to be the final record of all Depositors. No notice of any trust, express or implied, shall be entered upon the Record of Depositors otherwise than pursuant to an order of a court of competent jurisdiction or as required by law, and a Holder shall be deemed to be the beneficial owner of the Structured Warrants standing to the credit of his/its Securities Account, until such time as the Structured Warrants are duly transferred to another Holder and the name of the transferee is entered in the Record of Depositors.

ANNEXURE I **PRINCIPAL TERMS OF THE DEED POLL** (cont'd)**14 Meetings of Holders**

- 14.1 The procedure governing the convening and conduct of meetings of the Holders are set out in the Fourth Schedule to the Deed Poll.

15 Notices

- 15.1 Subject to Condition 15.2:
- (a) all notices to the Holders pertaining to the convening of meetings shall be made by way of notice published in at least one (1) English language national daily newspaper and announced through Bursa Securities; and
 - (b) all other notices shall either be announced through the Bursa Securities or published in at least one (1) English language national daily newspaper.
- 15.2 A notice is deemed to have been given and served to the Holders on the date of announcement or publication as the case may be or, if announced or published more than once or on different dates, on the first date on which it is announced or published.
- 15.3 All notices effected in accordance with this Condition 15 shall be deemed to be effective in respect of all persons who become Holders after the date of the relevant notice.
- 15.4 For the avoidance of doubt, a notice shall not be required to be published or announced in respect of an event contemplated under Conditions 6, 8, 9, 10, 11 or 11A, as the case may be, if no adjustment to the rights of the Holders or amendment to the terms and conditions of the relevant Structured Warrants is made or to be made pursuant thereto.

16 Modification of rights

- 16.1 All or any of the rights for the time being attached to the Structured Warrants (other than the Exercise Price which a Holder is entitled to or the formulae for the adjustment of the Exercise Price or the Exercise Ratio or any other condition, which may be modified in accordance with the provisions set out elsewhere in these Conditions) may be altered or abrogated by the Issuer from time to time (whether or not the Issuer is being wound up), and the sanction of a Special Resolution passed at a meeting of the Holders held as aforesaid shall be necessary to effect such alteration or abrogation.
- 16.2 Notwithstanding Condition 16.1, the Issuer may without the consent of the Holders but in accordance with the terms of the Deed Poll, effect any modification to the Structured Warrants or the Deed Poll which, in the opinion of the Issuer, is:
- (a) not materially prejudicial to the interests of the Holders; or
 - (b) of a formal, minor or technical nature; or
 - (c) necessary or expedient to correct a manifest error, or to comply with mandatory provisions of law; or
 - (d) necessary or expedient to facilitate scripless trading in or exercise of the Structured Warrants or payment by way of electronic funds transfer as approved by the relevant government or statutory authorities in respect of the Structured Warrants or to amend the restrictions on transfer or exercise of the Structured Warrants to comply with the requirements of or the concessions granted by any relevant government or statutory authorities.
- Any such modification shall be binding on all Holders and shall be notified by the Issuer to them as soon as practicable thereafter in accordance with Condition 15 but in any event not later than twenty (20) Market Days from the date of such modification.
- 16.3 Notwithstanding Condition 16.1, the Issuer may, at any time and from time to time for the purpose of an issue of new Structured Warrants or a new Series of Structured Warrants through the Base Prospectus and without the consent or sanction of the Holders supplement the Deed Poll with the

ANNEXURE I PRINCIPAL TERMS OF THE DEED POLL (cont'd)

terms and conditions of the new Structured Warrants or Series of Structured Warrants (as set out in the relevant Term Sheet), as the case may be. In the event such supplement to the Deed Poll shall affect the rights and interests of the Holders, the Issuer is to effect such supplement to the Deed Poll by notice to the Holders in accordance with Condition 15 and such supplement shall be binding on all Holders without any further action being required to be taken by the Issuer. For the avoidance of doubt, a Holder is deemed to have notice of all announcements (and their respective contents) made by the Issuer to Bursa Securities in respect of or affecting the Series of Structured Warrants held.

17 Warrant Agency Agreement

- 17.1 The Structured Warrants Registrar acts as an agent of the Issuer and shall not assume any obligation or duty to or any relationship of agency or trust for the Holders except only as described in Condition 17.2.
- 17.2 The Warrant Agency Agreement contains provisions for the indemnification of the Structured Warrants Registrar. The Structured Warrants Registrar shall not be liable to any Holder in respect of any losses, liabilities, costs, claims, actions or demands which such Holder may suffer or incur or allege to have suffered or incurred as a result of or in connection with the exercise or non-exercise of any Structured Warrants Registrar's powers, discretions and/or duties. The Structured Warrants Registrar may:
- (a) in the exercise of its powers, discretions and/or duties, act on the advice or opinion of, or any certificate or information obtained in good faith from, any lawyer, valuer, accountant, banker, broker, securities company or other expert whether obtained by the Issuer, the relevant Structured Warrants Registrar or otherwise (which advice, opinion, certificate or information may be sent or obtained by letter, email, telex, telegram, cable or facsimile device) and the Structured Warrants Registrar shall not be liable for any loss occasioned by acting in good faith on any such advice, opinion, certificate or information unless there are reasonable grounds for concluding that the same may be forged or otherwise not authentic or containing some errors with respect to content, delivery or transmission;
 - (b) receive and retain without liability to account, such fee or other remuneration as may from time to time be agreed between the Issuer and the Structured Warrants Registrar; and
 - (c) enter into or be interested in any contract or financial or other transaction or arrangement with the Issuer or any person or body corporate associated with the Issuer in connection therewith to receive and retain, without liability to account any profit, fee, remuneration or other benefit received thereby or in connection therewith.

The Structured Warrants Registrar does not act as the agent of any Holder and therefore owes no fiduciary duty to any Holder in arriving at its calculations and determinations.

18 Exclusion of equities

- 18.1 Subject to the Central Depositories Act, the Rules of Bursa Depository, the Deed Poll, or these Conditions, no person shall be recognised by the Issuer as holding any Structured Warrants upon any trust, and the Issuer shall not be bound by or compelled in any way to recognise any equitable, contingent, future or partial interest in any Structured Warrant, or any interest in any fractional part of a Structured Warrant, or (except only as by these presents or by law otherwise provided) any other right in respect of any Structured Warrants, except an absolute right to the entirety thereof in the registered holder.

19 Force Majeure

- 19.1 If the Issuer determines that, for reasons beyond the Issuer's control, the performance of the Issuer's obligations under the Structured Warrants has become illegal or impractical in whole or in part for any reason, or the Issuer determines that, for reasons beyond the Issuer's control, it is no longer legal or practical for the Issuer to maintain the Issuer's hedging arrangements with respect to the Structured Warrants for any reason, the Issuer may in the Issuer's discretion and without

ANNEXURE I **PRINCIPAL TERMS OF THE DEED POLL** *(cont'd)*

obligation terminate the Structured Warrants early by giving notice to the Holders in accordance with Condition 15.

20 **Governing law**

20.1 The Structured Warrants and the Deed Poll are governed by and shall be construed in accordance with the laws of Malaysia. The Issuer and the Holders irrevocably agree that with respect to any proceedings in Malaysia in connection with any matter or issue relating to the Deed Poll and these Conditions, they shall be bound by the decision, ruling or order of the Malaysian Court.

(the remainder of this page is intentionally left blank)

ANNEXURE I PRINCIPAL TERMS OF THE DEED POLL (cont'd)**PART 2****CONDITIONS OF THE CASH-SETTLED BASKET EQUITIES CALL OR PUT WARRANTS****1 General, Nature, Form, Transfer, Administration and Status of Structured Warrants**

- 1.1 The Structured Warrants comprise **American or European style non-collateralised cash-settled call or put warrants over a basket of equities** to be issued from time to time by the Issuer through the Base Prospectus and subject to, and with the benefit of the Deed Poll referred to on the face of the Structured Warrant Certificate and these Conditions. The Exercise Rights entitle the Holder of each Structured Warrant for each Series of Structured Warrants issued or to be issued, subject to the Deed Poll and in accordance with these Conditions, upon valid exercise thereof, to the Cash Settlement Amount calculated in accordance with Condition 2. Certain statements in these Conditions are summaries of and are subject to the detailed provisions of the Deed Poll and in the event of any inconsistency between a provision contained in these Conditions and a provision contained in the Deed Poll, the provisions in the Deed Poll shall prevail. The Issuer has entered into a Warrant Agency Agreement with the Structured Warrants Registrar. Copies of the Deed Poll and the Warrant Agency Agreement are available for inspection at the registered office of the Issuer, being at the date hereof at 22nd Floor, Bangunan AmBank Group, No. 55 Jalan Raja Chulan, 50200 Kuala Lumpur, Malaysia. The Holders for the time being of the Structured Warrants and whose names appear on the Record of Depositors are all entitled to the benefit of, bound by, and deemed to have notice of, all the provisions of the Deed Poll and the Warrant Agency Agreement. Further, each Holder acknowledges it has, where necessary, consulted its stockbroker, solicitor or other adviser before investing in the Structured Warrants and none of the Issuer or its directors or employees may be construed as investment adviser or agent of, or owe any fiduciary duty to the Holder. **For the purposes of this Part 2, the term "Structured Warrants" shall refer to the American or European style non-collateralised cash-settled call or put warrants over a basket of equities.**
- 1.2 Subject to the Central Depositories Act, the Rules of Bursa Depository, the Deed Poll, the relevant applicable rules and regulations and these Conditions:
- (a) each Structured Warrant is an option which confers on the Holder the Exercise Rights which require the Issuer to make the Cash Settlement Amount to the Holder in accordance with these Conditions; and
 - (b) the Structured Warrants are issued in registered form, serially numbered and are a Prescribed Security to be admitted to the Official List. The Structured Warrants are represented by a global/jumbo certificate issued to Bursa Depository or its nominee who holds the same as bare trustee on behalf of the Holders, and deposited with Bursa Depository in or substantially in the form set out in the First Schedule to the Deed Poll as the same may from time to time be modified in accordance with the Deed Poll.
- 1.3 Subject to all information provided by the subscriber for the Structured Warrants to the Issuer being complete and consistent with the records of Bursa Depository, the Issuer shall within seven (7) Market Days from the date of allotment of the Structured Warrants, cause and procure the Structured Warrants Registrar to notify Bursa Depository of the names of the Holders together with such particulars as may be required by Bursa Depository for the purpose of making appropriate entries in the Securities Account of the respective Holder, request Bursa Depository to credit the Securities Account of the Holders with the applicable Structured Warrants and shall deliver to Bursa Depository the Structured Warrant Certificate registered in the name of Bursa Depository or its nominee company in such manner as may be prescribed by the Rules of Bursa Depository or agreed with Bursa Depository. If, at any time, the information provided by the Holders for the Structured Warrants is incorrect or inaccurate or inconsistent with the records of Bursa Depository, the Issuer reserves the right and without any obligation whatsoever to the Holders, to accept, reject or otherwise deal with the Structured Warrants in such manner as it reasonably deems fit in the circumstances. The Holders are not entitled to any physical warrant certificates.
- 1.4 Subject to the provisions of the Central Depositories Act and the Rules of Bursa Depository, the registration and subsequent administration of Structured Warrants shall be in the manner set forth in the Deed Poll and the Warrant Agency Agreement. It is hereby acknowledged that the Issuer

ANNEXURE I PRINCIPAL TERMS OF THE DEED POLL (cont'd)

shall be entitled to appoint registrars for the registration and administration of the Structured Warrants. The Issuer hereby confirms that it shall/has appointed the Structured Warrants Registrar for the purpose stipulated hereof, who shall perform such duties as required by the Issuer under the Deed Poll.

- 1.5 The Holders may transfer the Structured Warrants in the manner prescribed under the Central Depositories Act and the Rules of Bursa Depository. Subject to the provisions of the Central Depositories Act and the Rules of Bursa Depository, the Structured Warrants shall be freely transferable but the trading of the Structured Warrants must be in the same board lot applicable to the trading of the Underlying Equities or in such odd lots as permitted by the SC and/or Bursa Securities. Where the board lot of the Underlying Equity is more than one hundred (100) equities per board lot, the Structured Warrants may be issued in board lots of one hundred (100) warrants.
- 1.6 The Structured Warrants and the settlement obligation of the Issuer in respect of the Structured Warrants represent general and unsecured contractual obligations of the Issuer and of no other person which rank, and shall rank, equally among themselves and without preference in all respects, subject to such exceptions as may from time to time exist under applicable law or the Deed Poll, with the other existing and future unsecured and unsubordinated obligations of the Issuer.
- 1.7 The Structured Warrants do not confer on the Holders any right to acquire or dispose of equities or other securities, including the Underlying Equities and the Issuer is not under any obligation whatsoever to purchase, hold or deliver such equities or other securities, or any rights and benefits attaching thereto.
- 1.8 The Holders are entitled to the Cash Settlement Amount in accordance with Condition 2.

2 Exercise of the Structured Warrants**2.1 American style Structured Warrants**

- 2.1.1 The Structured Warrants may be exercised in the manner set out in Condition 2.1.2 at anytime from the date of issue up to the Expiry Date. In the event the date whereby the Exercise Form is delivered is not a Market Day, then it shall be deemed to be exercised on the next following Market Day.
- 2.1.2 In order to invoke the Exercise Rights, within the Exercise Period a Holder must complete and sign the Exercise Form (which shall be made available by the Structured Warrants Registrar in any manner as may be stipulated by Bursa Securities or such other relevant authority) and deliver the same on a Market Day between 9.00 a.m. to 5.00 p.m. to the Structured Warrants Registrar who shall acknowledge receipt by stamping the date and time of receipt on the Exercise Form in respect of which the Structured Warrants are being exercised.

Provided always that:

- (a) in every case compliance must also be made with the requirements set out in the Exercise Form and other prevailing statutory requirements for the time being applicable;
- (b) the Holder shall, if so required by the Structured Warrants Registrar, furnish such evidence, if any, as the Structured Warrants Registrar or the directors of the Issuer may require to determine the due execution of the Exercise Form by or on behalf of the Holder exercising the same. Once a valid Exercise Form is duly delivered by the Holder to the Structured Warrants Registrar, the exercise of such Exercise Rights shall be irrevocable save with the consent of the directors of the Issuer; and
- (c) where the Holder does not comply with the procedures or restrictions or conditions relating to the exercise of the Structured Warrants, the Exercise Form and any documents received shall be returned to such Holder by ordinary post to the Holder's address recorded in the Record of Depositors at the risk of the Holder.

ANNEXURE I **PRINCIPAL TERMS OF THE DEED POLL** (cont'd)

2.1.3 Subject to notification by the Structured Warrants Registrar of fulfilment of the preconditions by the Holder to validly exercise the Structured Warrants as set out in Condition 2.1.2 within three (3) Market Days from the Exercise Date and the absence of a Settlement Disruption Event, the Issuer shall, within seven (7) Market Days from the Exercise Date or such other period as may be prescribed by Bursa Securities or such other relevant authority, pay to the relevant Holder the Cash Settlement Amount calculated as set out below less Exercise Expenses, if any.

For call warrants:

$$\text{Cash Settlement Amount}^{(3)} = \text{Number of Structured Warrants} \times (\text{Closing Price}^{(1)} - \text{Exercise Price}^{(2)}) \times \frac{1}{\text{Exercise Ratio}^{(2)}}$$

Where:

- (1) The Closing Price shall be calculated by reference to either:
- (a) In the event a valid Exercise Form is received in accordance with Condition 2.1.2 by the Structured Warrants Registrar:
- (i) before 12.30 p.m. on any Market Day other than on the Expiry Date, the exercise of the Structured Warrants shall be deemed to have been made on that Market Day and in such instance the Market Day of receipt of the Exercise Form shall be the Exercise Date and Valuation Date and the Closing Price shall be the closing price of each of the Underlying Equity comprising the basket on such Valuation Date, adjusted for the relevant weighting of the Underlying Equity; or
- (ii) on or after 12.30 p.m. on any Market Day other than on the Expiry Date, the exercise of the Structured Warrants shall be deemed to have been made on the Market Day immediately following the Market Day of receipt of the Exercise Form and in such instance the Market Day immediately following the Market Day of receipt of the Exercise Form shall be the Exercise Date and the Valuation Date and the Closing Price shall be the closing price of the Underlying Equity comprising the basket on such Valuation Date, adjusted for the relevant weighting of the Underlying Equity. For the avoidance of doubt, if a valid Exercise Form is received on or after 12.30 p.m. on a Market Day immediately preceding the Expiry Date, the exercise of the Structured Warrants shall be deemed to have been made on the Expiry Date and in such instance the Closing Price shall be the Expiry Date Closing Price (as defined below) of the Underlying Equity comprising the basket; or
- (iii) on the Expiry Date, the Closing Price shall be the Expiry Date Closing Price (as defined below) of each of the Underlying Equity comprising the basket,

and as specified in the relevant Term Sheet and subject to the Market Disruption Event provision below.

If the Exercise Date falls within the Take-over Offer Period or the Compulsory Acquisition Period, the Closing Price shall be as calculated in the provision above or if the announced price for the Take-over Offer is lower than the Closing Price of the relevant Underlying Equities, the announced price for the Take-over Offer, shall form one of the components of the aggregate of the weighted Closing Prices.

If any of the Underlying Equities are suspended from trading as a result of the Take-over Offer or Compulsory Acquisition, and the Structured Warrants is only exercised subsequently, the Closing Price shall be based on the last quoted price of such Underlying Equities immediately before the suspension which shall form one of the components of the aggregate of the weighted Closing Prices (subject to the Market Disruption Event provision below), or if the announced price for the Take-over Offer is lower than the last quoted price of the relevant Underlying Equities, the announced price for the Take-over Offer shall form one of the components of the aggregate of the weighted Closing Prices.

For the avoidance of doubt, in the event any of the Underlying Equities are delisted, the Closing Price shall be determined in accordance with Condition 10.

If the Exercise Date falls on a Market Day when any of the Underlying Equities are suspended from trading for any other reason, the Closing Price shall be based on the last quoted price of such Underlying Equities immediately before the suspension which shall form one of the components of the aggregate of the weighted Closing Prices (subject to the Market Disruption Event provision below).

- (b) In the event of any exercise of the Structured Warrants on the Expiry Date, the Closing Price shall be calculated by reference to either:
- (i) the aggregate average VWAP of the Underlying Equities comprising the basket (subject to any adjustment as may be necessary to reflect any capitalisation, rights issue, distribution or others) for the five (5) Market Days prior to and including the Market Day immediately before the Expiry Date; or
 - (ii) the aggregate of the average closing price of the Underlying Equities comprising the basket (subject to any adjustment as may be necessary to reflect any capitalisation, rights issue, distribution or others) for the five (5) Market Days prior to and including the Market Day immediately before the Expiry Date; or
 - (iii) the aggregate of the weighted closing price of the Underlying Equities comprising the basket on the Market Day immediately before the Expiry Date,

and as specified in the relevant Term Sheet ("**Expiry Date Closing Price**") and subject to the Market Disruption Event and other provisions herein.

If the Expiry Date falls within the Take-over Offer Period or the Compulsory Acquisition Period, the Expiry Date Closing Price shall be (i) as calculated in the provision above, or (ii) if the announced price for the Take-over Offer is lower than the Closing Price of the relevant Underlying Equities, the announced price for the Take-over Offer shall form one of the components of the aggregate of the weighted Closing Prices.

If the Expiry Date falls on a Market Day when any of the Underlying Equities are suspended from trading as a result of Take-over Offer or Compulsory Acquisition, the Expiry Date Closing Price shall be based on the last quoted price of such Underlying Equities immediately before the suspension which shall form one of the components of the aggregate of the weighted Closing Prices (subject to the Market Disruption Event provision below), or if the announced price for the Take-over Offer is lower than the last quoted price of the relevant Underlying Equities, the announced price for the Take-over Offer shall form one of the components of the aggregate of the weighted Closing Prices.

ANNEXURE I**PRINCIPAL TERMS OF THE DEED POLL (cont'd)**

For the avoidance of doubt, in the event any of the Underlying Equities are delisted, the Expiry Date Closing Price shall be determined in accordance with Condition 10.

- (c) If a Market Disruption Event, or a public holiday unexpected by the Issuer occurs on any of the five (5) Market Days described in sub-Conditions (1)(b)(i) or (1)(b)(ii) above, the valuation period applicable and the Closing Price shall be as determined by the Issuer as it reasonably deems fit.

In any other cases where there is a single Valuation Date, if there is a Market Disruption Event on the Valuation Date, the Valuation Date shall be the next following Market Day after the Market Disruption Event. If the Market Disruption Event continues to occur up to eighth (8th) Business Day following the original Valuation Date, then the Valuation Date shall be:

- (i) that eighth (8th) Business Day; and
 - (ii) the Issuer shall determine as it reasonably deems fit and on the basis of the Issuer's good faith estimate the reference price and/or the exchange rate (if applicable) for that Valuation Date by determining the aggregate prices of the Underlying Equities and/or the exchange rate (if applicable) based on the prevailing market conditions and other factors as the Issuer may consider relevant.
- (2) The Exercise Price and/or Exercise Ratio shall be subject to such adjustments as may be necessary as provided in Condition 6.
- (3) In the event the Closing Price and the Exercise Price being quoted in a currency other than RM (as specified in the relevant Term Sheet), the Cash Settlement Amount shall be payable in RM, converted at the Settlement Exchange Rate.

For put warrants:

$$\text{Cash Settlement Amount}^{(3)} = \text{Number of Structured Warrants} \times (\text{Exercise Price}^{(2)} - \text{Closing Price}^{(1)}) \times \frac{1}{\text{Exercise Ratio}^{(2)}}$$

- (1) The Closing Price shall be calculated by reference to either:
- (a) In the event a valid Exercise Form is received in accordance with Condition 2.1.2 by the Structured Warrants Registrar:
 - (i) before 12.30 p.m. on any Market Day other than on the Expiry Date, the exercise of the Structured Warrants shall be deemed to have been made on that Market Day and in such instance the Market Day of receipt of the Exercise Form shall be the Exercise Date and Valuation Date and the Closing Price shall be the aggregate of the weighted closing prices of the Underlying Equities comprising the basket on the Market Day of receipt of the Exercise Form; or
 - (ii) on or after 12.30 p.m. on any Market Day other than on the Expiry Date, the exercise of the Structured Warrants shall be deemed to have been made on the Market Day immediately following the Market Day of receipt of the Exercise Form and in such instance the Market Day immediately following the Market Day of receipt of the Exercise Form shall be the Exercise Date and the Valuation Date and the Closing Price shall be the closing price of the Underlying Equity comprising the basket on such Valuation Date. For the avoidance of doubt, if a valid Exercise Form is received on or after 12.30 p.m. on a Market Day immediately preceding the Expiry Date, the exercise of the Structured Warrants shall be deemed to have been made on the Expiry Date and

ANNEXURE I**PRINCIPAL TERMS OF THE DEED POLL** (cont'd)

in such instance the Closing Price shall be the Expiry Date Closing Price (as defined below) of the Underlying Equities; or

- (iii) on the Expiry Date, the Closing Price shall be the Expiry Date Closing Price (as defined below) of the Underlying Equities comprising the basket,

and as specified in the relevant Term Sheet and subject to the Market Disruption Event provision below.

If the Exercise Date falls within the Take-over Offer Period or the Compulsory Acquisition Period, the Closing Price shall be as calculated in the provision above or if the announced price for the Take-over Offer is higher than the Closing Price of the relevant Underlying Equities, the announced price for the Take-over Offer, shall form one of the components of the aggregate of the weighted Closing Prices.

If any of the Underlying Equities are suspended from trading as a result of the Take-over Offer or Compulsory Acquisition, and the Structured Warrants is only exercised subsequently, the Closing Price shall be based on the last quoted price of such Underlying Equities immediately before the suspension which shall form one of the components of the aggregate of the weighted Closing Prices (subject to the Market Disruption Event provision below), or if the announced price for the Take-over Offer is higher than the last quoted price of the relevant Underlying Equities, the announced price for the Take-over Offer shall form one of the components of the aggregate of the weighted Closing Prices.

For the avoidance of doubt, in the event any of the Underlying Equities are delisted, the Closing Price shall be determined in accordance with Condition 10.

If the Exercise Date falls on a Market Day when any of the Underlying Equities are suspended from trading for any other reason, the Closing Price shall be based on the last quoted price of such Underlying Equities immediately before the suspension which shall form one of the components of the aggregate of the weighted Closing Prices (subject to the Market Disruption Event provision below).

- (b) In the event of any exercise of the Structured Warrants on the Expiry Date, the Closing Price shall be calculated by reference to either:
 - (i) the aggregate average VWAP of the Underlying Equities comprising the basket (subject to any adjustment as may be necessary to reflect any capitalisation, rights issue, distribution or others) for the five (5) Market Days prior to and including the Market Day immediately before the Expiry Date; or
 - (ii) the aggregate of the weighted average closing price of the Underlying Equities comprising the basket (subject to any adjustment as may be necessary to reflect any capitalisation, rights issue, distribution or others) for the five (5) Market Days prior to and including the Market Day immediately before the Expiry Date; or
 - (iii) the aggregate of the weighted closing price of the Underlying Equities comprising the basket on the Market Day immediately before the Expiry Date,

and as specified in the relevant Term Sheet ("**Expiry Date Closing Price**") and subject to the Market Disruption Event and other provisions herein.

If the Expiry Date falls within the Take-over Offer Period or the Compulsory Acquisition Period, the Expiry Date Closing Price shall be calculated as above

or if the announced price for the Take-over Offer is higher than the Closing Price of the relevant Underlying Equities, the announced price for the Take-over Offer shall form one of the components of the aggregate of the weighted Closing Prices.

If the Expiry Date falls on a Market Day when any of the Underlying Equities are suspended from trading as a result of Take-over Offer or Compulsory Acquisition, the Expiry Date Closing Price shall be based on the last quoted price of such Underlying Equities immediately before the suspension which shall form one of the components of the aggregate of the weighted Closing Prices (subject to the Market Disruption Event provision below), or if the announced price for the Take-over Offer is higher than the last quoted price of the relevant Underlying Equities, the announced price for the Take-over Offer shall form one of the components of the aggregate of the weighted Closing Prices.

For the avoidance of doubt, in the event any of Underlying Equities are delisted, the Expiry Date Closing Price shall be determined in accordance with Condition 10.

- (c) If a Market Disruption Event, or a public holiday unexpected by the Issuer occurs on any of the five (5) Market Days described in sub-Conditions (1)(b)(i) or (1)(b)(ii) above, the valuation period applicable and the Closing Price shall be as determined by the Issuer as it reasonably deems fit.

In any other cases where there is a single Valuation Date, if there is a Market Disruption Event on the Valuation Date, the Valuation Date shall be the next following Market Day after the Market Disruption Event. If the Market Disruption Event continues to occur up to eighth (8th) Business Day following the original Valuation Date, then the Valuation Date shall be:

- (i) that eighth (8th) Business Day; and
 - (ii) the Issuer shall determine as it reasonably deems fit and on the basis of the Issuer's good faith estimate the reference price and/or the exchange rate (if applicable) for that Valuation Date by determining the aggregate prices of the Underlying Equities and/or the exchange rate (if applicable) based on the prevailing market conditions and other factors as the Issuer may consider relevant.
- (2) The Exercise Price and/or Exercise Ratio shall be subject to such adjustments as may be necessary as provided in Condition 6.
- (3) In the event the Closing Price and the Exercise Price being quoted in a currency other than RM (as specified in the relevant Term Sheet), the Cash Settlement Amount shall be payable in RM, converted at the Settlement Exchange Rate.

2.1.4 In the event that the Cash Settlement Amount after deduction of the Exercise Expenses, if any, is equal to or less than zero, the Issuer shall not be obliged to make any payment to the relevant Holder, and the exercised Structured Warrants shall thereafter become void and cease to have the Exercise Rights and the Issuer's obligations in respect of the Structured Warrants shall terminate absolutely. For the avoidance of doubt, the Holder shall not be required to pay or top-up the Exercise Expenses, if any, as the case may be, where the Cash Settlement Amount after deduction of the Exercise Expenses, if any, is less than zero.

2.1.5 If the Structured Warrants are not earlier exercised, the Structured Warrants shall be deemed automatically exercised at 5.00 p.m. on the Expiry Date, without the Holders having to deliver a valid Exercise Form to the Structured Warrants Registrar and without notice of automatic exercise being given by the Issuer to the Holders.

ANNEXURE I **PRINCIPAL TERMS OF THE DEED POLL** (cont'd)

2.1.6 Upon automatic exercise of the Structured Warrants on the Expiry Date in accordance with Condition 2.1.5, if the Cash Settlement Amount after deduction of the Exercise Expenses, if any:

- (a) is greater than zero, in the absence of a Settlement Disruption Event, payment shall be made by the Issuer to the relevant Holders within seven (7) Market Days from the Expiry Date and the Issuer's obligations in respect of the Structured Warrants, shall terminate absolutely; or
- (b) is equal to or less than zero, the Structured Warrants shall terminate and cease to be valid and the Issuer's obligations in respect of the Structured Warrants, shall terminate absolutely. For the avoidance of doubt, the Holder shall not be required to pay or top-up the Exercise Expenses, if any, as the case may be, where the Cash Settlement Amount after deduction of the Exercise Expenses, if any, is less than zero.

2.2 European-style Structured Warrants

2.2.1 The Structured Warrants shall be automatically exercised at 5.00 p.m. on the Expiry Date if the Cash Settlement Amount calculated in accordance with Condition 2.2.2 after deduction of the Exercise Expenses, if any, is greater than zero (without the Holders having to deliver a valid Exercise Form and without notice of automatic exercise being given by the Issuer to the Holders). If the Expiry Date is not a Market Day then it shall be deemed to be exercised on the next following Market Day. The Structured Warrants will automatically terminate and cease to be valid at 5.00 p.m. on the Expiry Date if the Cash Settlement Amount after deduction of the Exercise Expenses, if any, is equal to or less than zero and the Issuer's obligations in respect of the Structured Warrants shall terminate absolutely. For the avoidance of doubt, the Holder shall not be required to pay or top-up the Exercise Expenses, if any, as the case may be, where the Cash Settlement Amount after deduction of the Exercise Expenses, if any, is less than zero.

2.2.2 The Issuer shall in the absence of a Settlement Disruption Event, within seven (7) Market Days from the Expiry Date or such other period as may be prescribed by Bursa Securities or such other relevant authority, pay to the relevant Holder, the Cash Settlement Amount calculated as set out below less Exercise Expenses, if any.

For call warrants:

$$\text{Cash Settlement Amount}^{(3)} = \text{Number of Structured Warrants} \times (\text{Closing Price}^{(1)} - \text{Exercise Price}^{(2)}) \times \frac{1}{\text{Exercise Ratio}^{(2)}}$$

Where:

- (1) (a) The Closing Price shall be calculated by reference to either:
 - (i) aggregate average VWAP of the Underlying Equities comprising the basket (subject to any adjustment as may be necessary to reflect any capitalisation, rights issue, distribution or others) for the five (5) Market Days prior to and including the Market Day immediately before the Expiry Date; or
 - (ii) the aggregate of the average closing price of the Underlying Equities comprising the basket (subject to any adjustment as may be necessary to reflect any capitalisation, rights issue, distribution or others) for the five (5) Market Days prior to and including the Market Day immediately before the Expiry Date; or
 - (iii) the aggregate of the weighted closing price of the Underlying Equities comprising the basket on the Market Day immediately before the Expiry Date,

and as specified in the relevant Term Sheet (“**Expiry Date Closing Price**”) and subject to the Market Disruption Event and other provisions herein.

If the Expiry Date falls within the Take-over Offer Period or the Compulsory Acquisition Period, the Expiry Date Closing Price shall be as calculated in the provision above or if the announced price for the Take-over Offer is lower than the Closing Price of the relevant Underlying Equities, the announced price for the Take-over Offer shall form one of the components of the aggregate of the weighted Closing Prices.

If the Expiry Date falls on a Market Day when any of the Underlying Equities are suspended from trading as a result of Take-over Offer or Compulsory Acquisition, the Expiry Date Closing Price shall be based on the last quoted price of such Underlying Equities immediately before the suspension which shall form one of the components of the aggregate of the weighted Closing Prices (subject to the Market Disruption Event provision below), or if the announced price for the Take-over Offer is lower than the last quoted price of the relevant Underlying Equities, the announced price for the Take-over Offer shall form one of the components of the aggregate of the weighted Closing Prices.

For the avoidance of doubt, in the event any of the Underlying Equities are delisted, the Expiry Date Closing Price shall be determined in accordance with Condition 10.

- (b) If a Market Disruption Event, or a public holiday unexpected by the Issuer occurs on any of the five (5) Market Days described in sub-Conditions (1)(a)(i) or (1)(a)(ii) above, the valuation period applicable and the Closing Price shall be as determined by the Issuer as it reasonably deems fit.

In any other cases where there is a single Valuation Date, if there is a Market Disruption Event on the Valuation Date, the Valuation Date shall be the next following Market Day after the Market Disruption Event. If the Market Disruption Event continues to occur up to eighth (8th) Business Day following the original Valuation Date, then the Valuation Date shall be:

- (i) that eighth (8th) Business Day; and
- (ii) the Issuer shall determine as it reasonably deems fit and on the basis of the Issuer’s good faith estimate the reference price and/or the exchange rate (if applicable) for that Valuation Date by determining the aggregate prices of the Underlying Equities and/or the exchange rate (if applicable) based on the prevailing market conditions and other factors as the Issuer may consider relevant.
- (2) The Exercise Price and/or Exercise Ratio shall be subject to such adjustments as may be necessary as provided in Condition 6.
- (3) In the event the Closing Price and the Exercise Price being quoted in a currency other than RM (as specified in the relevant Term Sheet), the Cash Settlement Amount shall be payable in RM, converted at the Settlement Exchange Rate.

For put warrants:

$$\text{Cash Settlement Amount}^{(3)} = \text{Number of Structured Warrants} \times (\text{Exercise Price}^{(2)} - \text{Closing Price}^{(1)}) \times \frac{1}{\text{Exercise Ratio}^{(2)}}$$

Where:

- (1) (a) The Closing Price shall be calculated by reference to either:

ANNEXURE I**PRINCIPAL TERMS OF THE DEED POLL (cont'd)**

- (i) aggregate average VWAP of the Underlying Equities comprising the basket (subject to any adjustment as may be necessary to reflect any capitalisation, rights issue, distribution or others) for the five (5) Market Days prior to and including the Market Day immediately before the Expiry Date; or
- (ii) the aggregate of the average closing price of the Underlying Equities comprising the basket (subject to any adjustment as may be necessary to reflect any capitalisation, rights issue, distribution or others) for the five (5) Market Days prior to and including the Market Day immediately before the Expiry Date; or
- (iii) the aggregate of the weighted closing price of the Underlying Equities comprising the basket on the Market Day immediately before the Expiry Date,

and as specified in the relevant Term Sheet ("**Expiry Date Closing Price**") and subject to the Market Disruption Event and other provisions herein.

If the Expiry Date falls within the Take-over Offer Period or the Compulsory Acquisition Period, the Expiry Date Closing Price shall be as calculated in the provision above or if the announced price for the Take-over Offer is higher than the Closing Price of the relevant Underlying Equities, the announced price for the Take-over Offer shall form one of the components of the aggregate of the weighted Closing Prices.

If the Expiry Date falls on a Market Day when any of the Underlying Equities are suspended from trading as a result of Take-over Offer or Compulsory Acquisition, the Expiry Date Closing Price shall be based on the last quoted price of such Underlying Equities immediately before the suspension which shall form one of the components of the aggregate of the weighted Closing Prices (subject to the Market Disruption Event provision below), or if the announced price for the Take-over Offer is higher than the last quoted price of the relevant Underlying Equities, the announced price for the Take-over Offer shall form one of the components of the aggregate of the weighted Closing Prices.

For the avoidance of doubt, in the event any of the Underlying Equities are delisted, the Expiry Date Closing Price shall be determined in accordance with Condition 10.

- (b) If a Market Disruption Event, or a public holiday unexpected by the Issuer occurs on any of the five (5) Market Days described in sub-Conditions (1)(a)(i) or (1)(a)(ii) above, the valuation period applicable and the Closing Price shall be as determined by the Issuer as it reasonably deems fit.

In any other cases where there is a single Valuation Date, if there is a Market Disruption Event on the Valuation Date, the Valuation Date shall be the next following Market Day after the Market Disruption Event. If the Market Disruption Event continues to occur up to eighth (8th) Business Day following the original Valuation Date, then the Valuation Date shall be:

- (i) that eighth (8th) Business Day; and
- (ii) the Issuer shall determine as it reasonably deems fit and on the basis of the Issuer's good faith estimate the reference price and/or the exchange rate (if applicable) for that Valuation Date by determining the aggregate prices of the Underlying Equities and/or the exchange rate (if applicable) based on the prevailing market conditions and other factors as the Issuer may consider relevant.

ANNEXURE I**PRINCIPAL TERMS OF THE DEED POLL (cont'd)**

- (2) The Exercise Price and/or Exercise Ratio shall be subject to such adjustments as may be necessary as provided in Condition 6.
- (3) In the event the Closing Price and the Exercise Price being quoted in a currency other than RM (as specified in the relevant Term Sheet), the Cash Settlement Amount shall be payable in RM, converted at the Settlement Exchange Rate.
- 2.2.3 In the event that the Cash Settlement Amount after deduction of the Exercise Expenses, if any, is equal to or less than zero on the Expiry Date, the Structured Warrants shall terminate on the Expiry Date and cease to be valid and the Issuer's obligations in respect of the Structured Warrants shall terminate absolutely. For the avoidance of doubt, the Holder shall not be required to pay or top-up the Exercise Expenses, if any, as the case may be, where the Cash Settlement Amount after deduction of the Exercise Expenses, if any, is less than zero.
- 2.3 (a) The Cash Settlement Amount less the Exercise Expenses, if any, shall be made by way of cheque drawn in favour of the Holder to be delivered by ordinary post to the Holder's address last recorded in the Record of Depositors at the Holder's own risk or by way of electronic transfer of funds to the bank account of the Holder, the details of which are provided by Bursa Depository to the Issuer at the request of the Issuer. Where the Issuer makes a payment to a Holder pursuant to the terms of Conditions 2.1 or 2.2, the amount of such payment arising from the exercise of the Structured Warrants shall be final and conclusive and the Issuer shall be discharged from its obligation upon making such payment thereof in accordance with these Conditions.
- (b) The Cash Settlement Amount less the Exercise Expenses, if any, shall be calculated and be payable in the Settlement Currency and rounded down to the nearest two (2) decimal points. All determinations made by the Issuer pursuant to Conditions 2.1 or 2.2 shall be final and conclusive and binding on the Holders.
- (c) The Holder is to bear all Exercise Expenses, if any, in relation to the exercise of the Structured Warrants and on exercise of the Structured Warrants, the Issuer shall be irrevocably authorised by the Holder to deduct all Exercise Expenses, if any, from the Cash Settlement Amount.
- (d) If as a result of a Settlement Disruption Event, it is not possible for the Issuer to make payment on the original Settlement Date, the Issuer shall use its reasonable endeavours to procure payment as soon as practicable after the original Settlement Date. The Issuer shall not be liable to the Holder for any interest in respect of the amount due or any loss or damage that such Holder may suffer as a result of the existence of the Settlement Disruption Event.
- 2.4 The Issuer shall not allow the Holder to exercise the Exercise Rights unless the Structured Warrants are or have been designated as "free securities" in accordance with the Rules of Bursa Depository.
- 2.5 The Issuer declares that approval shall be sought from Bursa Securities for the admission of the Structured Warrants to the Official List and for the listing of and quotation for the Structured Warrants on Bursa Securities.
- 2.6 All questions as to the validity, form, eligibility (including time of receipt) and acceptance of Exercise Form shall be resolved by the Structured Warrants Registrar in a manner as it reasonably deems fit, whose determination shall be final and binding on the Issuer and the Holder. The Structured Warrants Registrar is entitled to reject any Exercise Form that is not in proper form or the acceptance of which may, in the view of counsel for the Structured Warrants Registrar be unlawful. The Structured Warrants Registrar also reserves the right, subject to applicable law, to waive any irregularities. The interpretation of the Structured Warrants Registrar of the terms and conditions of exercise of the Structured Warrants shall be final and binding on the Issuer and the Holder. Unless waived, any irregularities in connection with the Exercise Form must be rectified by such time, as the Structured Warrants Registrar shall determine. The Structured Warrants Registrar shall not be under any duty to give notification of any irregularities in such Exercise Form and shall not incur

ANNEXURE I PRINCIPAL TERMS OF THE DEED POLL (cont'd)

liabilities for failure to give such notification. The Exercise Form shall not be considered to have been validly delivered until such irregularities have been rectified and waived.

- 2.7 The initial Structured Warrants Registrar and its specified offices are stated in the Deed Poll. The Issuer reserves the right at any time to terminate the appointment of the Structured Warrants Registrar. Prior written notice of any termination, appointment of the Structured Warrants Registrar, resignation of any Structured Warrants Registrar or any changes in any of the specified offices of the relevant Structured Warrants Registrar shall be given to the Holders in accordance with Condition 15 and such prior notice shall be given to the Holders not more than sixty (60) days and less than thirty (30) days of such termination, appointment, resignation or change.
- 2.8 In respect of each Structured Warrant in which Exercise Rights have been exercised, the Issuer shall instruct or procure the Structured Warrants Registrar to instruct Bursa Depository, to debit the appropriate number of Structured Warrants in respect of which Exercise Rights have been exercised from the Securities Account of such Holder. The Issuer shall be entitled at any time on or after the Expiry Date, to demand that Bursa Depository deliver to the Issuer the Structured Warrant Certificates and thereafter cancel or cause the cancellation of the Structured Warrant Certificates.
- 2.9 The Structured Warrants subject to the Exercise Rights which have been exercised in accordance with the Deed Poll shall cease to exist and all obligations of the Issuer in respect of those Structured Warrants shall terminate absolutely following payment of the amount (if any) referred to in this Condition 2.

3 Exercise Rights and Suspension

- 3.1 Upon and subject to the provisions of the Central Depositories Act, the Rules of Bursa Depository and the Deed Poll, the Holder whose name as stated in the Record of Depositors shall have the right at any time during the Exercise Period to invoke its Exercise Rights at the Exercise Price subject to adjustments in accordance with Condition 6.
- 3.2 The Structured Warrants shall, subject to any directions, order or notice from any relevant regulatory authority and any request for suspension by the Issuer which is not rejected by any such relevant regulatory authority, continue to be traded notwithstanding that the trading of the Underlying Equities of any one or more of the Underlying Companies, may have been suspended. Any suspension in the trading of the Underlying Equities or the Structured Warrants shall not preclude the Holder from exercising the Exercise Rights.
- 3.3 The Issuer shall notify the Holders of the Expiry Date at least one (1) month prior to the Expiry Date or such other period as may be specified by the relevant authority. Such notice shall be given in accordance with Condition 15 stating the Expiry Date and treatment of the Structured Warrants which are not exercised.

4 Deposit and Forfeiture of Unclaimed Amount

- 4.1 In the event that the Issuer pays the Cash Settlement Amount to any Holder under Condition 2 and such Holder does not present the cheque for payment within six (6) months from the date of the cheque, the Issuer shall at any time thereafter deal with the said monies in accordance and in compliance with, the requirements of the Unclaimed Moneys Act 1965 (Act 370) (revised 1989) of Malaysia.

5 Designation of Structured Warrants set out in the Exercise Form

- 5.1 Subject to the approval of Bursa Depository and/or other relevant authority, the Issuer reserves all rights to instruct Bursa Depository and/or other relevant authority to designate the Structured Warrants held in the relevant Securities Account of a Holder which the Holder has purportedly exercised by submitting an Exercise Form to the Issuer and/or the Structured Warrants Registrar, in order for Bursa Depository and/or the relevant authority to prohibit the Holder from trading on the exchange the designated Structured Warrants after the aforesaid exercise. The Issuer's right to instruct Bursa Depository and/or the relevant authority shall be independent of whether the exercise

ANNEXURE I **PRINCIPAL TERMS OF THE DEED POLL** (cont'd)

is valid or otherwise, provided that the amount of Structured Warrants so designated by Bursa Depository and/or the relevant authority do not exceed the amount set out in such Exercise Form.

6 Adjustment of Exercise Price and/or Exercise Ratio**6.1 Adjustments**

Subject to the Conditions as hereinafter provided and the Deed Poll, the Exercise Price and/or Exercise Ratio shall from time to time be adjusted in accordance with the following provisions:

(a) Bonus Issue

If and whenever any of the Underlying Companies of the relevant Structured Warrants shall make an issue of new equities ("**Equities**") credited as fully paid-up to the holders of Equities generally by way of capitalisation of profits or reserves (other than pursuant to a scrip dividend or similar scheme for the time being operated by the relevant Underlying Company or otherwise in lieu of a cash dividend and without any payment or other consideration being made or given by such holders) ("**Bonus Issue**"), the Exercise Price and/or Exercise Ratio shall be adjusted on the Market Day immediately following the last day on which an instrument of transfer could be lodged so that the transferee of the Equities would qualify for the Bonus Issue in accordance with the following formula:

(i) Adjusted Exercise Ratio =

$$\frac{E}{(1 + N)}$$

(ii) Adjusted Exercise Price =

$$\frac{X}{(1 + N)}$$

Whereby in respect of this Condition 6.1(a)(i) and (ii):

X = Existing Exercise Price of the Underlying Company making the Bonus Issue immediately prior to the Bonus Issue.

N = The number of additional Equities (whether a whole or a fraction) received by a holder of existing Equities for each Equity (of the relevant Underlying Company) held prior to the Bonus Issue.

E = Existing Exercise Ratio immediately prior to the Bonus Issue.

Alternatively, the Issuer may also, in good faith, make a corresponding adjustment to the Exercise Ratio and/or Exercise Price as the Issuer determines appropriate to account for the dilutive effect of the Bonus Issue.

On any such adjustment, the resultant Exercise Price and/or Exercise Ratio shall be rounded to the nearest four (4) decimal points of the Relevant Currency and all such adjustment made by the Issuer pursuant to this Condition shall be deemed as final and conclusive save for any manifest error.

(b) Rights Issue

If and whenever an Underlying Company of the relevant Structured Warrants shall, by way of Rights (as defined below), offer new Equities for subscription at a fixed subscription price ("**Rights Issue Price**") to the holders of existing Equities pro rata to the holders' existing holdings ("**Rights Issue**"), the Exercise Price and/or the Exercise Ratio shall be adjusted on the Market Day immediately following the last day on which an instrument of transfer of such Equities could be lodged so that the transferee of the Equities would qualify for the Rights Issue in accordance with the following formula:

ANNEXURE I **PRINCIPAL TERMS OF THE DEED POLL** (cont'd)

- (i) Adjusted Exercise Ratio =
- $$\frac{1 + (R/S) \times M}{1 + M} \times E$$
- (ii) Adjusted Exercise Price =
- $$\frac{1 + (R/S) \times M}{1 + M} \times X$$

Whereby, in respect of this Condition 6.1(b)(i) and (ii):

- R = Subscription price per Share of the Underlying Company of the relevant Structured Warrants under the Rights Issue.
- S = Cum-rights share price being the last traded price of an existing Equity of the Underlying Company of the relevant Structured Warrants making the Rights Issue on the last Market Day on which the Equities (of the Underlying Company of the relevant Structured Warrants making the Rights Issue) are traded on a cum-rights basis.
- M = Number of new Equities (whether a whole or fraction) per existing equity of the Underlying Company of the relevant Structured Warrants making the Rights Issue each holder thereof is entitled to subscribe.
- X = Existing Exercise Price immediately prior to the Rights Issue.
- E = Existing Exercise Ratio immediately prior to the Rights Issue.

Alternatively, the Issuer may also, in good faith, make a corresponding adjustment to the Exercise Ratio and/or Exercise Price as the Issuer determines appropriate to account for the dilutive effect of the Rights Issue.

On any such adjustment, the resultant Exercise Ratio and/or Exercise Price shall be rounded to the nearest four (4) decimal points of the Relevant Currency and all such adjustment made by the Issuer pursuant to this Condition shall be deemed as final and conclusive save for any manifest error.

For the purposes hereof, "**Rights**" means the Right(s) attached to each existing Equity or needed to acquire one new Equity (as the case may be) which are given to the holders of existing Equities to subscribe for new Equities at a fixed subscription price pursuant to the Rights Issue (whether by the exercise of one Right, a part of a Right or an aggregate number of Rights).

- (c) Subdivision or Consolidation

If and whenever the Underlying Company of the relevant Structured Warrants shall subdivide its Equities or any class of its outstanding share capital comprising the Equities into a greater number of Equities (a "**Subdivision**"), or consolidate the Equities or any class of its outstanding share capital comprising the Equities into a smaller number of Equities (a "**Consolidation**"), the Exercise Price and/or the Exercise Ratio shall be adjusted on the Market Day on which the relevant Subdivision or Consolidation shall have taken effect in accordance with the following formula:

- (i) Adjusted Exercise Ratio =
- $$\frac{E \times P}{N}$$

ANNEXURE I **PRINCIPAL TERMS OF THE DEED POLL** (cont'd)

(ii) Adjusted Exercise Price =

$$\frac{X \times P}{N}$$

Whereby, in respect of this Condition 6.1(c)(i) and (ii):

- X = Existing Exercise Price immediately prior to the Subdivision or Consolidation.
- N = Revised number of issued shares after the Subdivision or Consolidation.
- P = Existing number of issued shares immediately prior to the Subdivision or Consolidation.
- E = Existing Exercise Ratio immediately prior to the Subdivision or Consolidation.

Alternatively, the Issuer may also, in good faith, make adjustment to the Exercise Ratio and/or Exercise Price as the Issuer determines appropriate to account for the dilutive or consolidative effect of the Subdivision or Consolidation.

On any such adjustment, the resultant Exercise Ratio and/or Exercise Price shall be rounded to the nearest four (4) decimal points of the Relevant Currency and all such adjustment made by the Issuer pursuant to this Condition shall be deemed as final and conclusive save for any manifest error.

(d) Capital Repayment

Should any of the Underlying Company of the relevant Structured Warrants undertake a capital repayment in cash whether in the form of special dividend or not (pursuant to Section 115 of the Companies Act 2016 or such other corresponding provision in the Relevant Country in which the Underlying Equities are listed and quoted) during the tenure of the Structured Warrants, the Exercise Price and/or the Exercise Ratio of the Structured Warrants shall be adjusted on the Market Day following the last day on which an instrument of transfer is lodged to enable the transferee of the Equities to qualify for the capital repayment by the amount of the capital repayment, net of taxation, if any.

The Exercise Price for the Structured Warrants shall be adjusted in accordance with the following formula:

(i) Adjusted Exercise Ratio =

$$E \times \frac{(P - D)}{P}$$

(ii) Adjusted Exercise Price =

$$X \times \frac{(P - D)}{P}$$

Whereby, in respect of this Condition 6.1(d)(i) and (ii):

- P = Closing Price of the Underlying Equity on the last market day on which the Underlying Equities is traded on a cum-entitlement basis.
- D = The capital repayment per one (1) of the Underlying Equity held.
- X = Existing Exercise Price immediately prior to the capital repayment.
- E = Existing Exercise Ratio immediately prior to the capital repayment.

ANNEXURE I PRINCIPAL TERMS OF THE DEED POLL (cont'd)

The Exercise Ratio and/or Exercise Price of the Structured Warrants shall not be adjusted for capital repayment in specie or in the form of other securities, other than for bonus issue and rights issue pursuant to Conditions 6.1(a) and (b).

Alternatively, the Issuer may also, in good faith, make a corresponding adjustment to the Exercise Ratio and/or Exercise Price as the Issuer determines appropriate to account for the effect of the capital repayment.

On any such adjustment, the resultant Exercise Ratio and/or Exercise Price shall be rounded to the nearest four (4) decimal points of the Relevant Currency and all such adjustment made by the Issuer pursuant to this Condition shall be deemed as final and conclusive save for any manifest error.

Notwithstanding the above, if a capital repayment undertaken by the relevant Underlying Company results in a significant change in the business of such Underlying Company or such other circumstances as the Issuer may determine, the Issuer is entitled to terminate the Structured Warrants without prior notice to the Holders. If the Issuer terminates the Structured Warrants, then the Issuer will, if and to the extent permitted by applicable law, pay an amount to each Holder in respect of each Structured Warrant held by such Holder if the Cash Settlement Amount after deduction of the Exercise Expenses, if any, is greater than zero (without the Holder having to deliver a valid Exercise Form). The Cash Settlement Amount shall be determined by the Issuer as it reasonably deems fit based on the fair market value of the Structured Warrants (as determined by the Issuer) after taking into account the capital repayment exercise less all Exercise Expenses, if any.

(e) Other adjustments

The Issuer is entitled to make other adjustments as it reasonably believes are appropriate in circumstances where an event or events occur which the Issuer believes (notwithstanding any adjustment previously made by the Issuer) should, in the context of the issue of Structured Warrants and its obligations hereunder, give rise to such adjustment. The Issuer shall make such adjustment generally without considering the individual circumstances of any Holder or the tax or other consequences of such adjustment in any particular jurisdiction.

On any such adjustment, the resultant Exercise Price and/or Exercise Ratio shall be rounded to the nearest four (4) decimal points of the Relevant Currency.

6.2 Notwithstanding the foregoing, no adjustments shall be made to the Exercise Ratio and/or Exercise Price if the formulae stated in Condition 6.1(a) to Condition 6.1(e) results in an adjustment which would amount to less than two percent (2%) of the Exercise Ratio and/or Exercise Price being changed.

6.3 Any termination of Structured Warrants or adjustment made pursuant to Conditions 6.1 and 6.2 shall be final and binding on the Holders save in the case of manifest error. Notice of such termination, adjustments or amendments shall be given to the Holders as soon as practicable thereafter in accordance with Condition 15 and in any event within five (5) Market Days of the adjustment being made.

7 Restrictions to Protect Rights of Holders

7.1 As from the date of the issue of the Structured Warrants and for so long as any of the Structured Warrants remain exercisable, the Issuer shall have arrangements in place to ensure, for the benefit of the Holders that it is able to satisfy in full the exercise of all the Structured Warrants for the time being outstanding.

8 Merger or Consolidation of Underlying Company

8.1 In the event of a merger, amalgamation or reconstruction of any of the Underlying Companies wherein an Underlying Company is to or may merge or consolidate with or into any other corporation (including becoming, by agreement or otherwise, a subsidiary of any corporation or controlled by any person or corporation) (except where the Underlying Company is the surviving

ANNEXURE I **PRINCIPAL TERMS OF THE DEED POLL** (cont'd)

corporation in a merger), or is to or may sell or transfer all or substantially all of its assets ("**Restructuring Event**"), the Issuer may in good faith take any of the actions below:

- (a) cancel the Structured Warrants without prior notice to the Holders. If the Structured Warrants are so cancelled, the Issuer shall pay an amount to each Holder, if the Cash Settlement Amount after deduction of the Exercise Expenses, if any, is greater than zero (without the Holder having to deliver a valid Exercise Form). The Cash Settlement Amount shall be determined by the Issuer in a manner as it reasonably deems fit based on the fair market value of the Underlying Equities (as determined by the Issuer) after taking into account the Restructuring Event less all Exercise Expenses, if any; and/or
- (b) amend and determine the appropriate adjustment, if any, to be made to the terms and conditions of the Structured Warrants to account for the Restructuring Event and determine the effective date of that adjustment. After such adjustments (if any), the Structured Warrants shall relate to the number of equities of the corporation(s) resulting from or surviving such Restructuring Event or other securities ("**Substituted Securities**") and/or cash offered in substitution for the affected Underlying Equities of the relevant Structured Warrants to which the holder of such number of Underlying Equities to which the Structured Warrants related immediately before such Restructuring Event would have been entitled upon such Restructuring Event, as the case may be. The Issuer may, but need not, determine the appropriate adjustment by reference to the adjustment in respect of the Restructuring Event made by a Securities Exchange to options on the relevant Underlying Equities traded on that Securities Exchange.

8.2 Upon the occurrence of a Restructuring Event, the rights attaching to the Structured Warrants in respect of that Underlying Company may be amended by the Issuer no later than the Market Day preceding the consummation of such Restructuring Event.

8.3 The provisions of these Conditions shall apply to such Substituted Securities provided that, any Substituted Securities may, as the Issuer reasonably deems fit, be replaced by an amount in the Relevant Currency equal to the market value or, if no market value is available, fair value, of such Substituted Securities in each case as determined by the Issuer as soon as practicable after such Restructuring Event is effected.

8.4 Any cancellation of Structured Warrants or modification of rights made pursuant to Condition 8.1 or 8.2 shall be notified to the Holders as soon as practicable thereafter and in any event within five (5) Market Days from the date of such cancellation or modification in accordance with Condition 15.

9 Take-over Offer, Compulsory Acquisition or other Forms of Reorganisation in respect of the Underlying Company

9.1 Take-over Offer or Compulsory Acquisition

In the event of the Take-Over Offer or Compulsory Acquisition or any other event having similar effect on the rights of the Holders ("**Other Event**") no cancellation of the relevant Structured Warrants shall be effected and the relevant Structured Warrants shall remain exercisable by the Holder for the remaining tenure of the Exercise Period unless any such Take-Over Offer, Compulsory Acquisition or Other Event results in any of the circumstances referred to in Condition 10 or Condition 11, in which event, the relevant provisions of Condition 10 or Condition 11 shall apply.

9.2 Other Forms of Reorganisation

In the event of a scheme of arrangement or any other forms of reorganisation including any scheme of arrangement or reorganisation resulting in the privatisation of any of the Underlying Companies, or the Underlying Company is placed under a judicial management under any applicable laws, the Issuer is entitled to deal with the Structured Warrants in such manner as it reasonably deems fit in the circumstances and with or without any adjustments to the rights attaching to the relevant Structured Warrants.

ANNEXURE I **PRINCIPAL TERMS OF THE DEED POLL** (cont'd)**10 Delisting of the Underlying Equities**

- 10.1 If at any time any of the Underlying Equities cease to be listed on Bursa Securities or such other Securities Exchanges or an Underlying Company announces its intention to cease its listing status, or such Underlying Equities are suspended from trading on Bursa Securities or such other Securities Exchanges prior to, and in connection with the delisting of the Underlying Equities, such Underlying Equities shall remain as a component of the Structured Warrants over the remaining tenure of the relevant Structured Warrants and the last quoted price of such suspended or delisted (as the case may be) Underlying Equities immediately before the suspension or delisting (as the case may be) shall form one of the components of the aggregate of the weighted closing prices for the calculation of the Cash Settlement Amount (calculated in accordance with Condition 2) at any time after the suspension or delisting (as the case may be) of such Underlying Equities.
- 10.2 If any of the Underlying Equities are suspended or delisted (as the case may be) as a result of a Take-over Offer or Compulsory Acquisition, the last quoted price of the suspended or delisted (as the case may be) Underlying Equities immediately before the suspension or delisting (as the case may be) or the announced price for the Take-over Offer, whichever is lower (for call warrants) or higher (for put warrants), as the case may be, shall form one of the components of the aggregate of the weighted closing prices.
- 10.3 If the Underlying Equities of all of the Underlying Companies cease to be listed on the relevant Securities Exchanges or there are announcements of intentions to cease the listings of all the Underlying Companies or all of such Underlying Equities are suspended from trading on Bursa Securities or such other Securities Exchanges prior to, and in connection with the delisting of all such Underlying Equities, the Structured Warrants may if determined by the Issuer be automatically exercised without the Holder having to deliver a valid Exercise Form and without notice of automatic exercise being given by the Issuer to the Holder:
- (a) if the Cash Settlement Amount after deduction of the Exercise Expenses, if any, is greater than zero, the Issuer shall make payment of the Cash Settlement Amount to the relevant Holder; or
 - (b) if the Cash Settlement Amount after deduction of the Exercise Expenses, if any, is equal to or less than zero, the Issuer shall not be obliged to make any payment to the relevant Holder and the relevant Structured Warrants shall terminate and cease to be valid and the Issuer's obligations in respect of the Structured Warrants shall terminate absolutely. For the avoidance of doubt, the Holder shall not be required to pay or top-up the Exercise Expenses, if any, as the case may be, where the Cash Settlement Amount after deduction of the Exercise Expenses, if any, is less than zero.

The Closing Price for the calculation of the Cash Settlement Amount (calculated in accordance with Condition 2) shall be the aggregate of the weighted last quoted prices of the Underlying Equities immediately before such events or determined in accordance with Condition 2.1.3(1)(b) or 2.2.2, as the case may be, and the Issuer shall not be obliged to make any adjustment to the Exercise Price.

Provided that if there is a Market Disruption Event on the date immediately before such events ("**Set Date**"), the aggregate of the weighted last quoted prices of all the delisted Underlying Equities immediately before the suspension or delisting (as the case may be) shall form the Closing Price. If the preceding date is also affected by the Market Disruption Event then the Closing Price shall be determined by the Issuer on the Set Date as it reasonably deems fit and on the basis of the Issuer's good faith estimate the reference price and/or the exchange rate (if applicable) for that Set Date by determining the aggregate prices of the Underlying Equities and/or the exchange rate (if applicable) based on the prevailing market conditions and other factors as the Issuer may consider relevant.

- 10.4 Where two or more but not all of the Underlying Companies are or have been suspended or delisted (as the case may be), there shall be no automatic exercise of the Structured Warrants unless otherwise determined by the Issuer.
- 10.5 Subject to the aforesaid, the Issuer may but shall not be obliged to make any adjustment to the terms and conditions of the Structured Warrants and the rights attaching to the Structured Warrants

ANNEXURE I PRINCIPAL TERMS OF THE DEED POLL (cont'd)

as it shall reasonably consider appropriate to ensure that the interests of the Holders generally are not materially prejudiced as a consequence of such events, (without considering the individual circumstances of any Holder or the tax or other consequences that may result in any particular jurisdiction).

11 Liquidation, Dissolution or Winding-Up of the Underlying Company

11.1 If at any time any of the Underlying Companies of the Structured Warrants are liquidated, dissolved or wound up, the affected Underlying Equities shall remain as a component of the Structured Warrants over the remaining tenure of the relevant Structured Warrants and the closing price of such Underlying Equities on the Market Day immediately before the liquidation, dissolution or winding-up of the affected Underlying Company shall form one of the components of the aggregate of the weighted closing price for the calculation of the Cash Settlement Amount at any time after the liquidation, dissolution or winding-up of such Underlying Company and the Issuer shall not be obliged to make any adjustment to the Exercise Price.

In the event of the following:

- (a) public announcement on the liquidation, winding-up of all of the Underlying Companies; or
- (b) the appointment of liquidator, receiver or administrator or analogous person under any applicable law in respect of the whole or substantially the whole of all of the Underlying Companies' Assets,

the Structured Warrants will be automatically exercised and settled in cash without the Holder having to deliver a valid Exercise Form and without notice of automatic exercise being given by the Issuer to the Holder:

- (a) if the Cash Settlement Amount after deduction of the Exercise Expenses, if any, is greater than zero, the Issuer shall make payment of the Cash Settlement Amount to the relevant Holder; or
- (b) if the Cash Settlement Amount after deduction of the Exercise Expenses, if any, is equal to or less than zero, the Issuer shall not be obliged to make any payment to the relevant Holder and the relevant Structured Warrants shall terminate and cease to be valid and the Issuer's obligations in respect of the Structured Warrants shall terminate absolutely. For the avoidance of doubt, the Holder shall not be required to pay or top-up the Exercise Expenses, if any, as the case may be, where the Cash Settlement Amount after deduction of the Exercise Expenses, if any, is less than zero.

The Closing Price for the calculation of the Cash Settlement Amount (calculated in accordance with Condition 2) shall be the aggregate of the weighted closing prices of the Underlying Equities on the Market Day immediately before such events or determined in accordance with Condition 2.1.3(1)(b) or 2.2.2, as the case may be, and the Issuer shall not be obliged to make any adjustment to the Exercise Price.

Provided that if there is a Market Disruption Event on the Set Date, the aggregate of the weighted last quoted prices of all the affected Underlying Equities immediately before the liquidation, dissolution or winding-up shall form the Closing Price. If the preceding date is also affected by the Market Disruption Event then the Closing Price shall be determined by the Issuer on the Set Date as it reasonably deems fit on the basis of the Issuer's good faith estimate the reference price and/or the exchange rate (if applicable) for that Set Date by determining the aggregate prices of the Underlying Equities and/or the exchange rate (if applicable) based on the prevailing market conditions and other factors as the Issuer may consider relevant.

11.2 Subject to the aforesaid, the Issuer may but shall not be obliged to make any adjustment to the terms and conditions of the Structured Warrants and the rights attaching to the Structured Warrants as it shall reasonably consider appropriate to ensure that the interests of the Holders generally are not materially prejudiced as a consequence of such events (without considering the individual circumstances of any Holder or the tax or other consequences that may result in any particular jurisdiction).

ANNEXURE I PRINCIPAL TERMS OF THE DEED POLL (cont'd)**11A Takeover, Merger, Liquidation, Dissolution or Winding-Up of Issuer**

- 11A.1 In the event of a take-over or a scheme of arrangement or any other form of reorganisation undertaken by the Issuer or any other events having similar effects on the rights of the Holders, the Issuer is entitled to deal with the Structured Warrants in such manner as it reasonably deems fit in the circumstances and with or without any adjustments to the rights attaching to the relevant Structured Warrants.
- 11A.2 In the event of a merger, amalgamation or reconstruction of the Issuer, the corporation, trust or other body into which the Issuer is merged, amalgamated or reconstructed shall assume all the liabilities and the obligations of the Issuer in respect of the Structured Warrants so that the rights of the Holders shall continue to exist and be enforceable to the same extent as provided by the Issuer under the Deed Poll.
- 11A.3 In the event of a liquidation, dissolution or winding-up of the Issuer or the appointment of a receiver or administrator or analogous person under any applicable law in respect of the whole or substantially the whole of the Issuer's Assets, the Structured Warrants remaining outstanding shall be deemed to be exercised on the Market Day immediately prior to the date of such liquidation, dissolution, winding-up or appointment as follows:
- (a) All unexercised Structured Warrants shall automatically be exercised without the Holders having to deliver a valid Exercise Form and without notice of automatic exercise being given by the Issuer to the Holders:
 - (i) if the Cash Settlement Amount after deduction of the Exercise Expenses, if any, is greater than zero, the Issuer shall make payment of the Cash Settlement Amount to the relevant Holder; or
 - (ii) if the Cash Settlement Amount after deduction of the Exercise Expenses, if any, is equal to or less than zero, the Issuer shall not be obliged to make any payment to the relevant Holder and the relevant Structured Warrants shall terminate and cease to be valid and the Issuer's obligations in respect of the Structured Warrants shall terminate absolutely. For the avoidance of doubt, the Holder shall not be required to pay or top-up the Exercise Expenses, if any, as the case may be, where the Cash Settlement Amount after deduction of the Exercise Expenses, if any, is less than zero.

The closing price of the Underlying Equities on the Market Day immediately before the above events shall form the Closing Price for the calculation of the Cash Settlement Amount for the Structured Warrants.

- (b) Notwithstanding the foregoing, if, there is a Market Disruption Event on the Set Date, the Closing Price shall be based on the Market Day immediately preceding the Market Disruption Event. If the preceding Market Day is also affected by the Market Disruption Event, the Closing Price shall be determined by the Issuer on the Set Date as it reasonably deems fit and on the basis of the Issuer's good faith estimate of the reference price and/or the exchange rate (if applicable) for that Set Date by determining the price of the Underlying Equities and/or the exchange rate (if applicable) based on the prevailing market conditions and other factors as the Issuer may consider relevant.

12 Replacement of Structured Warrant Certificate

- 12.1 If the Structured Warrant Certificate which has been deposited with Bursa Depository is mutilated, defaced, lost, worn out, stolen or destroyed it shall be replaced by the Issuer at the registered office of the Structured Warrants Registrar on such terms as to evidence and indemnity or otherwise as the Issuer may require. All payment of such costs as may be incurred in connection therewith shall be borne by the Issuer. Mutilated, defaced, lost, worn, stolen or destroyed Structured Warrant Certificates shall be deemed cancelled.

ANNEXURE I **PRINCIPAL TERMS OF THE DEED POLL** (cont'd)**13 Register, Transfer and Transmission**

- 13.1 Each Holder registered in the Record of Depositors shall be entitled to all rights, benefits, powers and privileges and be subject to all liabilities, duties and obligations in respect of, or arising from the Structured Warrants, and shall be deemed and treated as the absolute owner of the relevant Structured Warrants, in accordance with the Central Depositories Act and the Rules of Bursa Depository, whether or not the Issuer shall be in default in respect of the Structured Warrants or any of the covenants contained herein and notwithstanding any notice of ownership or writing thereon or notice of any previous loss or theft of any Structured Warrants. The provisions of the Central Depositories Act, the Rules of Bursa Depository and the Issuer's constitution for the time being relating to the registration, transfer and transmission of shares and the fees payable thereon shall with necessary modifications apply to the registration, transfer and transmission of the legal ownership of the Structured Warrants, subject always to the provisions of this Condition 13 and Condition 2.
- 13.2 The entries made under the Record of Depositors shall be deemed to be the final record of all Depositors. No notice of any trust, express or implied, shall be entered upon the Record of Depositors otherwise than pursuant to an order of a court of competent jurisdiction or as required by law, and a Holder shall be deemed to be the beneficial owner of the Structured Warrants standing to the credit of his/its Securities Account, until such time as the Structured Warrants are duly transferred to another Holder and the name of the transferee is entered in the Record of Depositors.

14 Meetings of Holders

- 14.1 The procedure governing the convening and conduct of meetings of the Holders are set out in the Fourth Schedule to the Deed Poll.

15 Notices

- 15.1 Subject to Condition 15.2:
- (a) all notices to the Holders pertaining to the convening of meetings shall be made by way of notice published in at least one (1) English language national daily newspaper and announced through Bursa Securities; and
 - (b) all other notices shall either be announced through the Bursa Securities or published in at least one (1) English language national daily newspaper.
- 15.2 A notice is deemed to have been given and served to the Holders on the date of announcement or publication as the case may be or, if announced or published more than once or on different dates, on the first date on which it is announced or published.
- 15.3 All notices effected in accordance with this Condition 15 shall be deemed to be effective in respect of all persons who become Holders after the date of the relevant notice.
- 15.4 For the avoidance of doubt, a notice shall not be required to be published or announced in respect of an event contemplated under Conditions 6, 8, 9, 10, 11 or 11A, as the case may be, if no adjustment to the rights of the Holders or amendment to the terms and conditions of the relevant Structured Warrants is made or to be made pursuant thereto.

16 Modification of rights

- 16.1 All or any of the rights for the time being attached to the Structured Warrants (other than the Exercise Price which a Holder is entitled to or the formulae for the adjustment of the Exercise Price or the Exercise Ratio or any other condition, which may be modified in accordance with the provisions set out elsewhere in these Conditions) may be altered or abrogated by the Issuer from time to time (whether or not the Issuer is being wound up), and the sanction of a Special Resolution passed at a meeting of the Holders held as aforesaid shall be necessary to effect such alteration or abrogation.

ANNEXURE I **PRINCIPAL TERMS OF THE DEED POLL** (cont'd)

- 16.2 Notwithstanding Condition 16.1, the Issuer may without the consent of the Holders but in accordance with the terms of the Deed Poll, effect any modification to the Structured Warrants or the Deed Poll which, in the opinion of the Issuer, is:
- (a) not materially prejudicial to the interests of the Holders; or
 - (b) of a formal, minor or technical nature; or
 - (c) necessary or expedient to correct a manifest error, or to comply with mandatory provisions of law; or
 - (d) necessary or expedient to facilitate scripless trading in or exercise of the Structured Warrants or payment by way of electronic funds transfer as approved by the relevant government or statutory authorities in respect of the Structured Warrants or to amend the restrictions on transfer or exercise of the Structured Warrants to comply with the requirements of or the concessions granted by any relevant government or statutory authorities.

Any such modification shall be binding on all Holders and shall be notified by the Issuer to them as soon as practicable thereafter in accordance with Condition 15 but in any event not later than twenty (20) Market Days from the date of such modification.

- 16.3 Notwithstanding Condition 16.1, the Issuer may, at any time and from time to time for the purpose of an issue of new Structured Warrants or a new Series of Structured Warrants through the Base Prospectus and without the consent or sanction of the Holders supplement the Deed Poll with the terms and conditions of the new Structured Warrants or Series of Structured Warrants (as set out in the relevant Term Sheet), as the case may be. In the event such supplement to the Deed Poll shall affect the rights and interests of the Holders, the Issuer is to effect such supplement to the Deed Poll by notice to the Holders in accordance with Condition 15 and such supplement shall be binding on all Holders without any further action being required to be taken by the Issuer. For the avoidance of doubt, a Holder is deemed to have notice of all announcements (and their respective contents) made by the Issuer to Bursa Securities in respect of or affecting the Series of Structured Warrants held.

17 Warrant Agency Agreement

- 17.1 The Structured Warrants Registrar acts as an agent of the Issuer and shall not assume any obligation or duty to or any relationship of agency or trust for the Holders except only as described in Condition 17.2.
- 17.2 The Warrant Agency Agreement contains provisions for the indemnification of the Structured Warrants Registrar. The Structured Warrants Registrar shall not be liable to any Holder in respect of any losses, liabilities, costs, claims, actions or demands which such Holder may suffer or incur or allege to have suffered or incurred as a result of or in connection with the exercise or non-exercise of any Structured Warrants Registrar's powers, discretions and/or duties. The Structured Warrants Registrar may:
- (a) in the exercise of its powers, discretions and/or duties, act on the advice or opinion of, or any certificate or information obtained in good faith from, any lawyer, valuer, accountant, banker, broker, securities company or other expert whether obtained by the Issuer, the relevant Structured Warrants Registrar or otherwise (which advice, opinion, certificate or information may be sent or obtained by letter, email, telex, telegram, cable or facsimile device) and the Structured Warrants Registrar shall not be liable for any loss occasioned by acting in good faith on any such advice, opinion, certificate or information unless there are reasonable grounds for concluding that the same may be forged or otherwise not authentic or containing some errors with respect to content, delivery or transmission;
 - (b) receive and retain without liability to account, such fee or other remuneration as may from time to time be agreed between the Issuer and the Structured Warrants Registrar; and
 - (c) enter into or be interested in any contract or financial or other transaction or arrangement with the Issuer or any person or body corporate associated with the Issuer in connection

ANNEXURE I PRINCIPAL TERMS OF THE DEED POLL (cont'd)

therewith to receive and retain, without liability to account any profit, fee, remuneration or other benefit received thereby or in connection therewith.

The Structured Warrants Registrar does not act as the agent of any Holder and therefore owes no fiduciary duty to any Holder in arriving at its calculations and determinations.

18 Exclusion of equities

- 18.1 Subject to the Central Depositories Act, the Rules of Bursa Depository, the Deed Poll, or these Conditions, no person shall be recognised by the Issuer as holding any Structured Warrants upon any trust, and the Issuer shall not be bound by or compelled in any way to recognise any equitable, contingent, future or partial interest in any Structured Warrant, or any interest in any fractional part of a Structured Warrant, or (except only as by these presents or by law otherwise provided) any other right in respect of any Structured Warrants, except an absolute right to the entirety thereof in the registered holder.

19 Force Majeure

- 19.1 If the Issuer determines that, for reasons beyond the Issuer's control, the performance of the Issuer's obligations under the Structured Warrants has become illegal or impractical in whole or in part for any reason, or the Issuer determines that, for reasons beyond the Issuer's control, it is no longer legal or practical for the Issuer to maintain the Issuer's hedging arrangements with respect to the Structured Warrants for any reason, the Issuer may in the Issuer's discretion and without obligation terminate the Structured Warrants early by giving notice to the Holders in accordance with Condition 15.

20 Governing law

- 20.1 The Structured Warrants and the Deed Poll are governed by and shall be construed in accordance with the laws of Malaysia. The Issuer and the Holders irrevocably agree that with respect to any proceedings in Malaysia in connection with any matter or issue relating to the Deed Poll and these Conditions, they shall be bound by the decision, ruling or order of the Malaysian Court.

(the remainder of this page is intentionally left blank)

PART 3

CONDITIONS OF THE PHYSICAL-SETTLED SINGLE EQUITY CALL WARRANTS

1 General, Nature, Form, Transfer, Administration and Status of Structured Warrants

- 1.1 The Structured Warrants comprise **American or European style non-collateralised physical-settled call warrants over a single equity** to be issued from time to time by the Issuer through the Base Prospectus and subject to, and with the benefit of the Deed Poll referred to on the face of the Structured Warrant Certificate and these Conditions. The Exercise Rights entitle the Holder of each Structured Warrant for each Series of Structured Warrants issued or to be issued, subject to the Deed Poll and in accordance with these Conditions, upon valid exercise thereof, to the Physical Settlement Amount, Cash Settlement Amount for Odd Lots and/or Cash Settlement Amount, as the case may be, calculated in accordance with Condition 2. Certain statements in these Conditions are summaries of and are subject to the detailed provisions of the Deed Poll and in the event of any inconsistency between a provision contained in these Conditions and a provision contained in the Deed Poll, the provisions in the Deed Poll shall prevail. The Issuer has entered into a Warrant Agency Agreement with the Structured Warrants Registrar. Copies of the Deed Poll and the Warrant Agency Agreement are available for inspection at the registered office of the Issuer, being at the date hereof at 22nd Floor, Bangunan AmBank Group, No. 55 Jalan Raja Chulan, 50200 Kuala Lumpur, Malaysia. The Holders for the time being of the Structured Warrants and whose names appear on the Record of Depositors are all entitled to the benefit of, bound by, and deemed to have notice of, all the provisions of the Deed Poll and the Warrant Agency Agreement. Further, each Holder acknowledges it has, where necessary, consulted its stockbroker, solicitor or other adviser before investing in the Structured Warrants and none of the Issuer or its directors or employees may be construed as investment adviser or agent of, or owe any fiduciary duty to the Holder. **For the purposes of this Part 3, the term "Structured Warrants" shall refer to the American or European style non-collateralised physical-settled call warrants over a single equity.**
- 1.2 Subject to the Central Depositories Act, the Rules of Bursa Depository, the Deed Poll, the relevant applicable rules and regulations and these Conditions:
- (a) each Structured Warrant is an option which confers on the Holder the Exercise Rights which require the Issuer to make or pay the Physical Settlement Amount, Cash Settlement Amount for Odd Lots and/or Cash Settlement Amount, as the case may be, to the Holder in accordance with these Conditions; and
 - (b) the Structured Warrants are issued in registered form, serially numbered and are a Prescribed Security to be admitted to the Official List. The Structured Warrants are represented by a global/jumbo certificate issued to Bursa Depository or its nominee who holds the same as bare trustee on behalf of the Holders, and deposited with Bursa Depository in or substantially in the form set out in the First Schedule to the Deed Poll as the same may from time to time be modified in accordance with the Deed Poll.
- 1.3 Subject to all information provided by the subscriber for the Structured Warrants to the Issuer being complete and consistent with the records of Bursa Depository, the Issuer shall within seven (7) Market Days from the date of allotment of the Structured Warrants, cause and procure the Structured Warrants Registrar to notify Bursa Depository of the names of the Holders together with such particulars as may be required by Bursa Depository for the purpose of making appropriate entries in the Securities Account of the respective Holder, request Bursa Depository to credit the Securities Account of the Holders with the applicable Structured Warrants and shall deliver to Bursa Depository the Structured Warrant Certificate registered in the name of Bursa Depository or its nominee company in such manner as may be prescribed by the Rules of Bursa Depository or agreed with Bursa Depository. If, at any time, the information provided by the Holders for the Structured Warrants is incorrect or inaccurate or inconsistent with the records of Bursa Depository, the Issuer reserves the right and without any obligation whatsoever to the Holders, to accept, reject or otherwise deal with the Structured Warrants in such manner as it reasonably deems fit in the circumstances. The Holders are not entitled to any physical warrant certificates.
- 1.4 Subject to the provisions of the Central Depositories Act and the Rules of Bursa Depository, the registration and subsequent administration of Structured Warrants shall be in the manner set forth in the Deed Poll and the Warrant Agency Agreement. It is hereby acknowledged that the Issuer

ANNEXURE I PRINCIPAL TERMS OF THE DEED POLL (cont'd)

shall be entitled to appoint registrars for the registration and administration of the Structured Warrants. The Issuer hereby confirms that it shall/has appointed the Structured Warrants Registrar for the purpose stipulated hereof, who shall perform such duties as required by the Issuer under the Deed Poll.

- 1.5 The Holders may transfer the Structured Warrants in the manner prescribed under the Central Depositories Act and the Rules of Bursa Depository. Subject to the provisions of the Central Depositories Act and the Rules of Bursa Depository, the Structured Warrants shall be freely transferable but the trading of the Structured Warrants must be in the same board lot applicable to the trading of the Underlying Equity or in such odd lots as permitted by the SC and/or Bursa Securities. Where the board lot of the Underlying Equity is more than one hundred (100) equities per board lot, the Structured Warrants may be issued in board lots of one hundred (100) warrants.
- 1.6 The Structured Warrants and the settlement obligation of the Issuer in respect of the Structured Warrants represent general and unsecured contractual obligations of the Issuer and of no other person which rank, and shall rank, equally among themselves and without preference in all respects, subject to such exceptions as may from time to time exist under applicable law or the Deed Poll, with the other existing and future unsecured and unsubordinated obligations of the Issuer.
- 1.7 The Holders of the Structured Warrants are entitled to the Physical Settlement Amount, Cash Settlement Amount for Odd Lots and/or Cash Settlement Amount, as the case may be, in accordance with Condition 2 provided always that the settlement to the Holder shall be in cash if the Underlying Equity is securities quoted on a Securities Exchange outside Malaysia.

2 Exercise of the Structured Warrants**2.1 Exercise Rights****2.1.1 (a) American style Structured Warrants**

The Structured Warrants may be exercised in the manner set out in Condition 2.1.2 from the date of issue up to and including the Expiry Date. In the event the date whereby the Exercise Form is delivered is not a Market Day, then it shall be deemed to be exercised on the next following Market Day.

(b) European style Structured Warrants

The Structured Warrant may be exercised in the manner as set out in Condition 2.1.2 on the Expiry Date up to 9.00 a.m. on the fifth (5th) Market Day following the Expiry Date. If the Expiry Date is not a Market Day then it shall be deemed to be exercised on the next following Market Day.

- 2.1.2 In order to invoke the Exercise Rights, within the Exercise Period a Holder must complete and sign the Exercise Form (which shall be made available by the Structured Warrants Registrar in any manner as may be stipulated by Bursa Securities or such other relevant authority) and deliver the same on a Market Day between 9.00 a.m. to 5.00 p.m. to the Structured Warrants Registrar who shall acknowledge receipt by stamping the date and time of receipt on the Exercise Form in respect of which the Structured Warrants are being exercised.

Provided always that:

- (a) (i) in respect of the American style Structured Warrants, the payment by remittance of bankers' draft for the credit of the Issuer for the amount equal to the Exercise Price for all the Underlying Equity in respect of the Structured Warrants being exercised together with the transfer fee for Bursa Depository or such other fee as may be imposed by the relevant authority from time to time is received by the Issuer on the same Market Day of the receipt of the Exercise Form;

(ii) in respect of European style Structured Warrants, the Exercise Form is received by the Structured Warrant Registrar and the payment by remittance of bankers' draft for the credit of the Issuer for the amount equal to the Exercise Price for all the Underlying Equity in respect of the Structured Warrants being exercised together with the transfer fee for Bursa Depository or such other fee as may be

ANNEXURE I**PRINCIPAL TERMS OF THE DEED POLL (cont'd)**

imposed by the relevant authority from time to time is received by the Issuer, by 9.00 a.m. on the fifth (5th) Market Day following the Expiry Date;

- (b) in every case compliance must also be made with the requirements set out in the Exercise Form and other prevailing statutory requirements for the time being applicable;
 - (c) the Holder shall, if so required by the Structured Warrants Registrar, furnish such evidence, if any, as the Structured Warrants Registrar or the directors of the Issuer may require to determine the due execution of the Exercise Form by or on behalf of the Holder exercising the same. Once a valid Exercise Form is duly delivered by the Holder to the Structured Warrants Registrar and the payment is duly delivered by the Holder to the Issuer, the exercise of such Exercise Rights shall be irrevocable save with the consent of the directors of the Issuer; and
 - (d) where the Holder does not comply with the procedures or restrictions or conditions relating to the exercise of the Structured Warrants, the Exercise Form and any documents received shall be returned to such Holder by ordinary post to the Holder's address recorded in the Record of Depositors at the risk of the Holder.
- 2.1.3 Subject to notification by the Structured Warrants Registrar of fulfilment of the preconditions by the Holder to validly exercise the Structured Warrants as set out in Condition 2.1.2 within three (3) Market Days from the Exercise Date and the absence of a Settlement Disruption Event, the Issuer shall, within seven (7) Market Days from the Exercise Date or such other period as may be prescribed by Bursa Securities or such other relevant authority, deliver the Physical Settlement Amount comprising the relevant Underlying Equity to the exercising Holder by crediting the relevant number of Underlying Equity at the Exercise Ratio to the exercising Holder's Securities Account and despatch the notice of transfer to the Holder.

Provided always that the delivery of the Underlying Equity shall not be effected until the Issuer is satisfied that Exercise Price and Exercise Expenses, if any, have been received or shall be received by the Issuer from the Holder.

- 2.1.4 The Physical Settlement Amount shall be calculated based on the Exercise Ratio. All determinations made by the Issuer (in the absence of manifest error) shall be final and conclusive and binding on the Holders. If a book closure date has been declared by the Underlying Company and trading in the Underlying Equity is on a "cum-entitlement" basis on the Exercise Date, the Underlying Equity to be delivered by the Issuer to the Holder upon valid exercise of the Structured Warrants shall also be on a "cum-entitlement" basis.
- 2.1.5 In the event the Holder is entitled to receive odd lots of the Underlying Equity upon valid exercise of the Structured Warrants, the Issuer shall pay to the relevant Holder, in respect of such odd lots of the Underlying Equity, the Cash Settlement Amount for Odd Lots less all Exercise Expenses, if any, in the absence of a Settlement Disruption Event, within seven (7) Market Days from the Exercise Date or such other period as may be prescribed by Bursa Securities or such other relevant authority. The Cash Settlement Amount for Odd Lots less all Exercise Expenses, if any, is calculated as follows:

$$\text{Cash Settlement Amount for Odd Lots} = \text{Number of Underlying Equity in odd lots} \times \text{Closing Price}^{(1)}$$

- (1) As set out in Condition 2.1.7.

- 2.1.6 The Issuer shall be discharged from its obligation to deliver the Underlying Equity to the relevant Holders upon despatching the notice of transfer and making Cash Settlement Amount for Odd Lots (if any), to the exercising Holders in accordance with these Conditions.

- 2.1.7 (a) American style Structured Warrants

In the event the Issuer is unable to deliver the Underlying Equity upon valid exercise of the Structured Warrants by the Holders for reasons set out in Condition 2.1.11, and provided that the Cash Settlement Amount after deduction of the

ANNEXURE I**PRINCIPAL TERMS OF THE DEED POLL (cont'd)**

Exercise Expenses, if any, is greater than zero, the Issuer shall pay the Holders the Cash Settlement Amount less Exercise Expenses, if any, in the absence of a Settlement Disruption Event, within seven (7) Market Days from the Exercise Date or such other period as may be prescribed by Bursa Securities or such other relevant authority. The Cash Settlement Amount less Exercise Expenses, if any, is calculated as set out below:

$$\text{Cash Settlement Amount} = \text{Number of Structured Warrants} \times \frac{(\text{Closing Price}^{(1)} - \text{Exercise Price}^{(2)})}{\text{Exercise Ratio}^{(2)}} \times \text{Settlement Exchange Rate (if applicable)}$$

- (1) The Closing Price shall be calculated by reference to either:
- (a) In the event a valid Exercise Form is received in accordance with Condition 2.1.2 by the Structured Warrants Registrar:
- (i) before 12.30 p.m. on any Market Day other than on the Expiry Date, the exercise of the Structured Warrants shall be deemed to have been made on that Market Day and in such instance the Market Day of receipt of the Exercise Form shall be the Exercise Date and the Valuation Date and the Closing Price shall be the closing price of the Underlying Equity on such Valuation Date; or
- (ii) on or after 12.30 p.m. on any Market Day other than on the Expiry Date, the exercise of the Structured Warrants shall be deemed to have been made on the Market Day immediately following the Market Day of receipt of the Exercise Form and in such instance the Market Day immediately following the Market Day of receipt of the Exercise Form shall be the Exercise Date and the Valuation Date and the Closing Price shall be the closing price of the Underlying Equity on such Valuation Date. For the avoidance of doubt, if a valid Exercise Form is received on or after 12.30 p.m. on a Market Day immediately preceding the Expiry Date, the exercise of the Structured Warrants shall be deemed to have been made on the Expiry Date and in such instance the Closing Price shall be the Expiry Date Closing Price (as defined below) of the Underlying Equity; or
- (iii) on the Expiry Date, the Closing Price shall be the Expiry Date Closing Price (as defined below) of the Underlying Equity,

and as specified in the relevant Term Sheet and subject to the Market Disruption Event provision below.

If the Exercise Date falls within the Take Over Offer Period or the Compulsory Acquisition Period, the Closing Price shall be as calculated above or the announced price for the Take-over Offer, whichever is lower.

If the Underlying Equity is suspended from trading as a result of the Take-over Offer or the Compulsory Acquisition, and the Structured Warrants are only exercised subsequently, the Closing Price shall be the last quoted price of such Underlying Equity immediately before the suspension (subject to the Market Disruption Event provision below), or the announced price for the Take-over Offer, whichever is lower.

For the avoidance of doubt, in the event the Underlying Equity is delisted, the Closing Price shall be determined in accordance with Condition 10.

If the Exercise Date falls on a Market Day when the Underlying Equity is suspended from trading for any other reason, the Closing Price shall be the last quoted price of such Underlying Equity immediately before the suspension (subject to the Market Disruption Event provision below).

ANNEXURE I**PRINCIPAL TERMS OF THE DEED POLL (cont'd)**

- (b) In the event of any exercise of the Structured Warrants on the Expiry Date, the Closing Price shall be calculated by reference to either:
- (i) the average VWAP of the Underlying Equity (subject to any adjustment as may be necessary to reflect any capitalisation, rights issue, distribution or others) for the five (5) Market Days prior to and including the Market Day immediately before the Expiry Date; or
 - (ii) the average closing price of the Underlying Equity (subject to any adjustment as may be necessary to reflect any capitalisation, rights issue, distribution or others) for the five (5) Market Days prior to and including the Market Day immediately before the Expiry Date; or
 - (iii) the closing price of the Underlying Equity on the Market Day immediately before the Expiry Date,

and as specified in the relevant Term Sheet (“**Expiry Date Closing Price**”) and subject to the Market Disruption Event and other provisions herein.

If the Expiry Date falls within the Take-over Offer Period or the Compulsory Acquisition Period, the Expiry Date Closing Price shall be as calculated above or the announced price for the Take-over Offer, whichever is lower.

If the Expiry Date falls on a Market Day when the Underlying Equity is suspended from trading as a result of the Take-over Offer or the Compulsory Acquisition, the Expiry Date Closing Price shall be the last quoted price of such Underlying Equity immediately before the suspension (subject to the Market Disruption Event provision below), or the announced price for the Take-over Offer, whichever is lower.

For the avoidance of doubt, in the event the Underlying Equity is delisted, the Expiry Date Closing Price shall be determined in accordance with Condition 10.

- (c) If a Market Disruption Event, or a public holiday unexpected by the Issuer occurs on any of the five (5) Market Days described in sub-Conditions (1)(b)(i) or (1)(b)(ii) above, the valuation period applicable and the Closing Price shall be as determined by the Issuer in such manner as it reasonably deems fit.

In any other cases where there is a single Valuation Date, if there is a Market Disruption Event on the Valuation Date, the Valuation Date shall be the next following Market Day after the Market Disruption Event. If the Market Disruption Event continues to occur up to the eighth (8th) Business Day following the original Valuation Date, then the Valuation Date shall be:

- (i) that eighth (8th) Business Day; and
 - (ii) the Issuer shall determine as it reasonably deems fit and on the basis of the Issuer’s good faith estimate the reference price and/or the exchange rate (if applicable) for that Valuation Date by determining the price of the Underlying Equity and/or the exchange rate (if applicable) based on the prevailing market conditions and other factors as the Issuer may consider relevant.
- (2) The Exercise Price and/or Exercise Ratio shall be subject to such adjustments as may be necessary as provided in Condition 6. If the Holder has paid the Exercise Price, the Exercise Price shall be excluded from the calculation of the Cash Settlement Amount for Structured Warrants.

ANNEXURE I PRINCIPAL TERMS OF THE DEED POLL (cont'd)

(b) European style Structured Warrants

In the event the Issuer is unable to deliver the Underlying Equity upon valid exercise of the Structured Warrants by the Holders as a result of the events set out in Condition 2.1.11 and provided that the Cash Settlement Amount for the Structured Warrants after deduction of the Exercise Expenses, if any, is greater than zero, the Issuer shall pay the Holders the Cash Settlement Amount for the Structured Warrants less Exercise Expenses, if any, in the absence of a Settlement Disruption Event, within seven (7) Market Days from the Expiry Date or such other period as may be prescribed by Bursa Securities or such other relevant authority. The Cash Settlement Amount less Exercises Expenses, if any, for the Structured Warrants is calculated as set out below:

$$\text{Cash Settlement Amount} = \text{Number of Structured Warrants} \times (\text{Closing Price}^{(1)} - \text{Exercise Price}^{(2)}) \times \frac{1}{\text{Exercise Ratio}^{(2)}} \times \text{Settlement Exchange Rate (if applicable)}$$

(1) (a) The Closing Price on the Expiry Date shall be calculated by reference to either:

- (i) the average VWAP of the Underlying Equity (subject to any adjustment as may be necessary to reflect any capitalisation, rights issue, distribution or others) for the five (5) Market Days prior to and including the Market Day immediately before the Expiry Date; or
- (ii) the average closing price of the Underlying Equity (subject to any adjustment as may be necessary to reflect any capitalisation, rights issue, distribution or others) for the five (5) Market Days prior to and including the Market Day immediately before the Expiry Date; or
- (iii) the closing price of the Underlying Equity on the Market Day immediately before the Expiry Date,

and as specified in the relevant Term Sheet and subject to the Market Disruption Event and other provisions herein.

If the Expiry Date falls within the Take-over Offer Period or the Compulsory Acquisition Period, the Closing Price shall be as calculated above or the announced price for the Take-over Offer, whichever is lower.

If the Expiry Date falls on a Market Day when the Underlying Equity is suspended from trading as a result of the Take-over Offer or the Compulsory Acquisition, the Closing Price shall be the last quoted price of such Underlying Equity immediately before the suspension (subject to the Market Disruption Event provision below), or the announced price for the Take-over Offer, whichever is lower.

For the avoidance of doubt, in the event the Underlying Equity is delisted, the Closing Price shall be determined in accordance with Condition 10 below.

(b) If a Market Disruption Event, or a public holiday unexpected by the Issuer occurs on any of the five (5) Market Days described in sub-Conditions (1)(a)(i) or (1)(a)(ii) above, the valuation period applicable and the Closing Price shall be as determined by the Issuer in such manner as it reasonably deems fit.

In any other cases where there is a single Valuation Date, if there is a Market Disruption Event on the Valuation Date, the Valuation Date shall be the next following Market Day after the Market Disruption Event. If the Market Disruption Event continues to occur up to the eighth (8th) Business Day following the original Expiry Date, then the Expiry Date shall be:

ANNEXURE I**PRINCIPAL TERMS OF THE DEED POLL (cont'd)**

- (i) that eighth (8th) Business Day; and
 - (ii) the Issuer shall determine as it reasonably deems fit and on the basis of the Issuer's good faith estimate the reference price and/or the exchange rate (if applicable) for that Expiry Date by determining the price of the Underlying Equity and/or the exchange rate (if applicable) based on the prevailing market conditions and other factors as the Issuer may consider relevant.
- (2) The Exercise Price and/or Exercise Ratio shall be subject to such adjustments as may be necessary as provided in Condition 6. If the Holder has paid the Exercise Price in accordance with Condition 2.1.2(a), the Exercise Price shall be excluded from the calculation of the Cash Settlement Amount for the Structured Warrants.
- 2.1.8 Where the Issuer makes payment to a Holder pursuant to the terms of this Condition 2.1:
- (a) the payment of Cash Settlement Amount less the Exercise Expenses, or Cash Settlement Amount for Odd Lots less the Exercise Expenses, shall be made by way of cheque drawn in favour of the Holder to be delivered by ordinary post to the Holder's address last recorded in the Record of Depositors at the Holder's own risk or by way of electronic transfer of funds to the bank account of the Holder; and/or
 - (b) the payment of Physical Settlement Amount shall be made by crediting such amount by the Issuer, directly or indirectly to the Holder's Securities Account,
- the details of which are provided by Bursa Depository to the Issuer at the request of the Issuer. The Holder shall be deemed to have authorised Bursa Depository to disclose information of the Holder's Securities Account for the purpose of such payments.
- Where the Issuer makes a payment to a Holder pursuant to the terms of this Condition 2.1, the amount of such payment arising from the exercise of the Structured Warrants shall be final and conclusive and the Issuer shall be discharged from its obligation upon making such payment thereof in accordance with these Conditions.
- 2.1.9 The Cash Settlement Amount for Odd Lots less the Exercise Expenses, if any, or the Cash Settlement Amount less the Exercise Expenses, if any, shall be calculated and be payable in Settlement Currency and rounded down to the nearest two (2) decimal points. All determinations made by the Issuer pursuant to this Condition 2.1 shall be final and conclusive and binding on the Holders.
- 2.1.10 In the event that the Cash Settlement Amount for Odd Lots after deduction of the Exercise Expenses, if any, or the Cash Settlement Amount after deduction of the Exercise Expenses, if any, is equal to or less than zero, the Issuer shall not be obliged to make any payment to the relevant Holder, and the Structured Warrants exercised shall thereafter become void and cease to have the Exercise Rights and the Issuer's obligations in respect of the Structured Warrants shall terminate absolutely. For the avoidance of doubt, the Holder shall not be required to pay or top-up the Exercise Expenses, if any, as the case may be, where the Cash Settlement Amount after deduction of the Exercise Expenses, if any, is less than zero.
- 2.1.11 The events that would result to the Issuer being unable to settle the Structured Warrants by way of Physical Settlement Amount are liquidation, dissolution or winding-up of the Underlying Company as referred to in Condition 11 or the Underlying Equity is suspended or delisted upon valid exercise of the Structured Warrants by the Holders as referred to in Condition 10. Upon occurrence of any of these events, the Issuer shall make the necessary announcement prior to Expiry Date, that the Structured Warrants shall be cash-settled.
- 2.1.12 In respect of American style Structured Warrants, any unexercised structured warrants shall be automatically terminated at 5.00 p.m. on the Expiry Date. In respect of European-style Structured Warrants, any unexercised Structured Warrants shall be automatically terminated and cease to have the Exercise Rights after 9.00 a.m. on the fifth (5th) Market Day following the Expiry Date.

ANNEXURE I **PRINCIPAL TERMS OF THE DEED POLL** (cont'd)

- 2.1.13 The Holder is to bear all Exercise Expenses, if any, in relation to the exercise of Structured Warrants and on exercise of the Structured Warrants, the Issuer shall be irrevocably authorised by the Holders to deduct all Exercise Expenses, if any, from the Cash Settlement Amount for Odd Lot or the Cash Settlement Amount.
- 2.1.14 If as a result of a Settlement Disruption Event, it is not possible for the Issuer to make payment on the original Settlement Date, the Issuer shall use its reasonable endeavours to procure payment as soon as practicable after the original Settlement Date. The Issuer shall not be liable to the Holder for any interest in respect of the amount due or any loss or damage that such Holder may suffer as a result of the existence of the Settlement Disruption Event.
- 2.2 The Issuer shall not allow the Holder to exercise the Exercise Rights unless the Structured Warrants are or have been designated as "free securities" in accordance with the Rules of Bursa Depository.
- 2.3 The Issuer declares that approval shall be sought from Bursa Securities for the admission of the Structured Warrants to the Official List and for the listing of and quotation for the Structured Warrants on Bursa Securities.
- 2.4 All questions as to the validity, form, eligibility (including time of receipt) and acceptance of Exercise Form shall be resolved by the Structured Warrants Registrar in a manner as it reasonably deems fit, whose determination shall be final and binding on the Issuer and the Holder. The Structured Warrants Registrar is entitled to reject any Exercise Form that is not in proper form or the acceptance of which may, in the view of counsel for the Structured Warrants Registrar be unlawful. The Structured Warrants Registrar also reserves the right, subject to applicable law, to waive any irregularities. The interpretation of the Structured Warrants Registrar of the terms and conditions of exercise of the Structured Warrants shall be final and binding on the Issuer and the Holder. Unless waived, any irregularities in connection with the Exercise Form must be rectified by such time, as the Structured Warrants Registrar shall determine. The Structured Warrants Registrar shall not be under any duty to give notification of any irregularities in such Exercise Form and shall not incur liabilities for failure to give such notification. The Exercise Form shall not be considered to have been validly delivered until such irregularities have been rectified and waived.
- 2.5 The initial Structured Warrants Registrar and its specified offices are stated in the Deed Poll. The Issuer reserves the right at any time to terminate the appointment of the Structured Warrants Registrar. Prior written notice of any termination, appointment of Structured Warrants Registrar, resignation of the Structured Warrants Registrar or any changes in any of the specified offices of the relevant Structured Warrants Registrar shall be given to the Holders in accordance with Condition 15 and such prior notice shall be given to the Holders not more than sixty (60) days and less than thirty (30) days of such termination, appointment, resignation or change.
- 2.6 In respect of each Structured Warrant in which Exercise Rights have been exercised, the Issuer shall instruct or procure the Structured Warrants Registrar to instruct Bursa Depository to debit the appropriate number of Structured Warrants in respect of which Exercise Rights have been exercised from the Securities Account of such Holder. The Issuer shall be entitled at any time on or after the Expiry Date, to demand that Bursa Depository deliver to the Issuer the Structured Warrant Certificates and thereafter cancel or cause the cancellation of the Structured Warrant Certificates.
- 2.7 The Structured Warrants subject to the Exercise Rights which have been exercised in accordance with the Deed Poll shall cease to exist and all obligations of the Issuer in respect of those Structured Warrants shall terminate absolutely following payment of the amount (if any) referred to in this Condition 2.
- 3 Exercise Rights and Suspension**
- 3.1 Upon and subject to the provisions of the Central Depositories Act, the Rules of Bursa Depository and the Deed Poll, the Holder whose name as stated in the Record of Depositors shall have the right at any time during the Exercise Period to invoke its Exercise Rights at the Exercise Price subject to adjustments in accordance with Condition 6.

ANNEXURE I PRINCIPAL TERMS OF THE DEED POLL (cont'd)

- 3.2 The Structured Warrants shall, subject to any directions, order or notice from any relevant regulatory authority and any request for suspension by the Issuer which is not rejected by any such relevant regulatory authority, continue to be traded notwithstanding that the trading of the Underlying Equity may have been suspended. Any suspension in the trading of the Underlying Equity or the Structured Warrants shall not preclude the Holder from exercising the Exercise Rights.
- 3.3 The Issuer shall notify the Holders of the Expiry Date at least one (1) month prior to the Expiry Date or such other period as may be specified by the relevant authority. Such notice shall be given in accordance with Condition 15 stating the Expiry Date and treatment of the Structured Warrants which are not exercised.

4 Deposit and Forfeiture of Unclaimed Amount

- 4.1 In the event that the Issuer pays the Cash Settlement Amount for Odd Lots or Cash Settlement Amount to any Holder under Condition 2 and such Holder does not present the cheque for payment within six (6) months from the date of the cheque, the Issuer shall at any time thereafter deal with the said monies in accordance and in compliance with, the requirements of the Unclaimed Moneys Act 1965 (Act 370) (revised 1989) of Malaysia.

5 Designation of Structured Warrants set out in the Exercise Form

- 5.1 Subject to the approval of Bursa Depository and/or other relevant authority, the Issuer reserves all rights to instruct Bursa Depository and/or other relevant authority to designate the Structured Warrants held in the relevant Securities Account of a Holder which the Holder has purportedly exercised by submitting an Exercise Form to the Issuer and/or the Structured Warrants Registrar, in order for Bursa Depository and/or the relevant authority to prohibit the Holder from trading on the exchange the designated Structured Warrants after the aforesaid exercise. The Issuer's right to instruct Bursa Depository and/or the relevant authority shall be independent of whether the exercise is valid or otherwise, provided that the amount of Structured Warrants so designated by Bursa Depository and/or the relevant authority do not exceed the amount set out in such Exercise Form.

6 Adjustment of Exercise Price and/or Exercise Ratio**6.1 Adjustments**

Subject to the Conditions as hereinafter provided and the Deed Poll, the Exercise Price and/or the Exercise Ratio for the relevant Structured Warrant shall from time to time be adjusted in accordance with the following provisions:

(a) Bonus Issue

If and whenever the Underlying Company of the relevant Structured Warrants shall make an issue of new equities ("**Equities**") credited as fully paid-up to the holders of Equities generally by way of capitalisation of profits or reserves (other than pursuant to a scrip dividend or similar scheme for the time being operated by the relevant Underlying Company or otherwise in lieu of a cash dividend and without any payment or other consideration being made or given by such holders) ("**Bonus Issue**"), the Exercise Price and/or Exercise Ratio shall be adjusted on the Market Day immediately following the last day on which an instrument of transfer could be lodged so that the transferee of the Equities would qualify for the Bonus Issue in accordance with the following formula:

- (i) Adjusted Exercise Ratio =
$$\frac{E}{(1 + N)}$$
- (ii) Adjusted Exercise Price =
$$\frac{X}{(1 + N)}$$

Whereby in respect of this Condition 6.1(a)(i) and (ii):

X = Existing Exercise Price immediately prior to the Bonus Issue.

ANNEXURE I **PRINCIPAL TERMS OF THE DEED POLL** (cont'd)

N = The number of additional Equities (whether a whole or a fraction) received by a holder of existing Equities for each Equity of the relevant Underlying Company held prior to the Bonus Issue.

E = Existing Exercise Ratio immediately prior to the Bonus Issue.

Alternatively, the Issuer may also, in good faith, make a corresponding adjustment to the Exercise Ratio and/or Exercise Price as the Issuer determines appropriate to account for the dilutive effect of the Bonus Issue.

On any such adjustment, the resultant Exercise Ratio and/or Exercise Price shall be rounded to the nearest four (4) decimal points of the Relevant Currency and all such adjustment made by the Issuer pursuant to this Condition shall be deemed as final and conclusive save for any manifest error.

(b) Rights Issue

If and whenever an Underlying Company of the relevant Structured Warrants shall, by way of Rights (as defined below), offer new Equities for subscription at a fixed subscription price ("**Rights Issue Price**") to the holders of existing Equities pro rata to the holders' existing holdings ("**Rights Issue**"), the Exercise Price and/or the Exercise Ratio shall be adjusted on the Market Day immediately following the last day on which an instrument of transfer of such Equities could be lodged so that the transferee of the Equity(ies) would qualify for the Rights Issue in accordance with the following formula:

(i) Adjusted Exercise Ratio =

$$\frac{1 + (R/S) \times M}{1 + M} \times E$$

(ii) Adjusted Exercise Price =

$$\frac{1 + (R/S) \times M}{1 + M} \times X$$

Whereby, in respect of this Condition 6.1(b)(i) and (ii):

R = Subscription price per Equity of the Underlying Company of the relevant Structured Warrants under the Rights Issue.

S = Cum-rights share price being the last traded price of an existing Equity of the Underlying Company of the relevant Structured Warrants making the Rights Issue on the last Market Day on which the Equities (of the Underlying Company of the relevant Structured Warrants making the Rights Issue) are traded on a cum-rights basis.

M = Number of new Equities (whether a whole or fraction) per existing equity of the Underlying Company of the relevant Structured Warrants making the Rights Issue each holder thereof is entitled to subscribe.

X = Existing Exercise Price immediately prior to the Rights Issue.

E = Existing Exercise Ratio immediately prior to the Rights Issue.

Alternatively, the Issuer may also, in good faith, make a corresponding adjustment to the Exercise Ratio and/or Exercise Price as the Issuer determines appropriate to account for the dilutive effect of the Rights Issue.

On any such adjustment, the resultant Exercise Ratio and/or Exercise Price shall be rounded to the nearest four (4) decimal points of the Relevant Currency and all such adjustment made by the Issuer pursuant to this Condition shall be deemed as final and conclusive save for any manifest error.

For the purposes hereof, "**Rights**" means the Right(s) attached to each existing Equity or needed to acquire one new Equity (as the case may be) which are given to the holders of

ANNEXURE I **PRINCIPAL TERMS OF THE DEED POLL** (cont'd)

existing Equities to subscribe for new Equities at a fixed subscription price pursuant to the Rights Issue (whether by the exercise of one Right, a part of a Right or an aggregate number of Rights).

(c) Subdivision or Consolidation

If and whenever the Underlying Company of the relevant Structured Warrants shall subdivide its Equities or any class of its outstanding share capital comprising the Equities into a greater number of Equities (a "**Subdivision**"), or consolidate the Equities or any class of its outstanding share capital comprising the Equities into a smaller number of Equities (a "**Consolidation**"), the Exercise Price and/or the Exercise Ratio shall be adjusted on the Market Day on which the relevant Subdivision or Consolidation shall have taken effect in accordance with the following formula:

(i) Adjusted Exercise Ratio =

$$E \times \frac{P}{N}$$

(ii) Adjusted Exercise Price =

$$X \times \frac{P}{N}$$

Whereby, in respect of this Condition 6.1(c)(i) and (ii):

X = Existing Exercise Price immediately prior to the Subdivision or Consolidation.

N = Revised number of issued shares after the Subdivision or Consolidation.

P = Existing number of issued shares immediately prior to the Subdivision or Consolidation.

E = Existing Exercise Ratio immediately prior to the Subdivision or Consolidation.

Alternatively, the Issuer may also, in good faith, make a corresponding adjustment to the Exercise Ratio and/or Exercise Price as the Issuer determines appropriate to account for the dilutive or consolidative effect of the Subdivision or Consolidation.

On any such adjustment, the resultant Exercise Ratio and/or Exercise Price shall be rounded to the nearest four (4) decimal points of the Relevant Currency and all such adjustment made by the Issuer pursuant to this Condition shall be deemed as final and conclusive save for any manifest error.

(d) Capital Repayment

Should the Underlying Company of the relevant Structured Warrants undertake a capital repayment in cash whether in the form of special dividend or not (pursuant to Section 115 of the Companies Act 2016 or such other corresponding provision in the Relevant Country which the Underlying Equity is listed and quoted) during the tenure of the Structured Warrants, the Exercise Price and/or the Exercise Ratio of the Structured Warrants shall be adjusted on the Market Day following the last day on which an instrument of transfer is lodged to enable the transferee of the Equities to qualify for the capital repayment by the amount of the capital repayment, net of taxation, if any.

The Exercise Ratio and Exercise Price for the Structured Warrants shall be adjusted in accordance with the following formula:

ANNEXURE I **PRINCIPAL TERMS OF THE DEED POLL** (*cont'd*)

(i) Adjusted Exercise Ratio =

$$E \times \frac{(P - D)}{P}$$

(ii) Adjusted Exercise Price =

$$X \times \frac{(P - D)}{P}$$

Whereby, in respect of this Condition 6.1(d)(i) and (ii) :

P = Closing Price of the Underlying Equity on the last market day on which the Underlying Equity is traded on a cum-entitlement basis.

D = The capital repayment per one (1) Underlying Equity held.

X = Existing Exercise Price immediately prior to the capital repayment.

E = Existing Exercise Ratio immediately prior to the capital repayment.

The Exercise Ratio and/or Exercise Price of the Structured Warrants shall not be adjusted for capital repayment in specie or in the form of other securities, other than for bonus issue and rights issue pursuant to Conditions 6.1(a) and (b).

Alternatively, the Issuer may also, in good faith, make a corresponding adjustment to the Exercise Ratio and/or Exercise Price as the Issuer determines appropriate to account for the effect of the capital repayment.

On any such adjustment, the resultant Exercise Ratio and/or Exercise Price shall be rounded to the nearest four (4) decimal points of the Relevant Currency and all such adjustment made by the Issuer pursuant to this Condition shall be deemed as final and conclusive save for any manifest error.

Notwithstanding the above, if a capital repayment undertaken by the relevant Underlying Company results in a significant change in the business of such Underlying Company or such other circumstances as the Issuer may determine, the Issuer is entitled to terminate the Structured Warrants without prior notice to the Holders. If the Issuer terminates the Structured Warrants, then the Issuer will, if and to the extent permitted by applicable law, pay an amount to each Holder in respect of each Structured Warrant held by such Holder if the Cash Settlement Amount after deduction of the Exercise Expenses, if any, is greater than zero (without the Holder having to deliver a valid Exercise Form). The Cash Settlement Amount shall be determined by the Issuer in a manner as it reasonably deems fit based on the fair market value of the Structured Warrants (as determined by the Issuer) after taking into account the capital repayment exercise less all Exercise Expenses, if any.

(e) Other adjustments

The Issuer is entitled to make other adjustments as it reasonably believes are appropriate in circumstances where an event or events occur which the Issuer believes (notwithstanding any adjustment previously made by the Issuer) should, in the context of the issue of Structured Warrants and its obligations hereunder, give rise to such adjustment. The Issuer shall make such adjustment generally without considering the individual circumstances of any Holder or the tax or other consequences of such adjustment in any particular jurisdiction.

On any such adjustment, the resultant Exercise Ratio and/or Exercise Price shall be rounded to the nearest four (4) decimal points of the Relevant Currency.

6.2 Notwithstanding the foregoing, no adjustments shall be made to the Exercise Ratio and/or Exercise Price if the formulae stated in Condition 6.1(a) to Condition 6.1(e) results in an adjustment which would amount to less than two percent (2%) of the Exercise Ratio and/or Exercise Price being changed.

6.3 Any termination of Structured Warrants or adjustment made pursuant to Conditions 6.1 and 6.2 shall be final and binding on the Holders save in the case of manifest error. Notice of such

ANNEXURE I PRINCIPAL TERMS OF THE DEED POLL (cont'd)

termination, adjustments or amendments shall be given to the Holders as soon as practicable thereafter in accordance with Condition 15 and in any event within five (5) Market Days of such termination or adjustment being made.

7 Restrictions to Protect Rights of Holders

- 7.1 As from the date of the issue of the Structured Warrants and for so long as any of the Structured Warrants remain exercisable, the Issuer shall have arrangements in place to ensure, for the benefit of the Holders that it is able to satisfy in full the exercise of all the Structured Warrants for the time being outstanding.

8 Merger or Consolidation of Underlying Company

- 8.1 In the event of a merger, amalgamation or reconstruction of the Underlying Company wherein an Underlying Company is to or may merge or consolidate with or into any other corporation (including becoming, by agreement or otherwise, a subsidiary of any corporation or controlled by any person or corporation) (except where the Underlying Company is the surviving corporation in a merger), or is to or may sell or transfer all or substantially all of its assets ("**Restructuring Event**"), the Issuer may in good faith take any of the actions below:

- (a) cancel the Structured Warrants without prior notice to the Holders. If the Structured Warrants are so cancelled, the Issuer shall pay an amount to each Holder, if the Cash Settlement Amount after deduction of the Exercise Expenses, if any, is greater than zero (without the Holder having to deliver a valid Exercise Form). The Cash Settlement Amount by the Issuer in a manner as it reasonably deems fit shall be determined based on the fair market value of the Underlying Equity (as determined by the Issuer) after taking into account the Restructuring Event less all Exercise Expenses, if any; and/or
- (b) amend and determine the appropriate adjustment, if any, to be made to the terms and conditions of the Structured Warrants to account for the Restructuring Event and determine the effective date of that adjustment. After such adjustments (if any), the Structured Warrants shall relate to the number of equities of the corporation(s) resulting from or surviving such Restructuring Event or other securities ("**Substituted Securities**") and/or cash offered in substitution for the affected Underlying Equity of the relevant Structured Warrants to which the holder of such number of Underlying Equity to which the Structured Warrants related immediately before such Restructuring Event would have been entitled upon such Restructuring Event, as the case may be. The Issuer may, but need not, determine the appropriate adjustment by reference to the adjustment in respect of the Restructuring Event made by a Securities Exchange to options on the relevant Underlying Equity traded on that Securities Exchange.

- 8.2 Upon the occurrence of a Restructuring Event, the rights attaching to the Structured Warrants in respect of that Underlying Company may be amended by the Issuer no later than the Market Day preceding the consummation of such Restructuring Event.

- 8.3 The provisions of these Conditions shall apply to such Substituted Securities provided that, any Substituted Securities may, as the Issuer reasonably deems fit, be replaced by an amount in the Relevant Currency equal to the market value or, if no market value is available, fair value, of such Substituted Securities in each case as determined by the Issuer as soon as practicable after such Restructuring Event is effected.

- 8.4 Any cancellation of Structured Warrants or modification of rights made pursuant to Condition 8.1 or 8.2 shall be notified to the Holders as soon as practicable thereafter and in any event within five (5) Market Days from the date of such cancellation or modification in accordance with Condition 15.

9 Take-over Offer, Compulsory Acquisition or other Forms of Reorganisation in respect of the Underlying Company

- 9.1 Take-over Offer or Compulsory Acquisition

In the event of the Take-Over Offer or Compulsory Acquisition or any other event having similar effect on the rights of the Holders ("**Other Event**") no cancellation of the relevant Structured Warrants shall be effected and the relevant Structured Warrants shall remain exercisable by the

ANNEXURE I **PRINCIPAL TERMS OF THE DEED POLL** (cont'd)

Holder for the remaining tenure of the Exercise Period unless any such Take-Over Offer, Compulsory Acquisition or Other Event results in any of the circumstances referred to in Condition 10 or Condition 11, in which event, the relevant provisions of Condition 10 or Condition 11 shall apply.

9.2 Other Forms of Reorganisation

In the event of a scheme of arrangement or any other forms of reorganisation including any scheme of arrangement or reorganisation resulting in the privatisation of the Underlying Company, or the Underlying Company is placed under a judicial management under any applicable laws, the Issuer is entitled to deal with the Structured Warrants in such manner as it reasonably deems fit in the circumstances and with or without any adjustments to the rights attaching to the relevant Structured Warrants.

10 Delisting of the Underlying Equity

10.1 If at any time the Underlying Equity of the Structured Warrants ceases to be listed on Bursa Securities or such other Securities Exchanges or there is an announcement of an intention to cease the listing status of the Underlying Company or such Underlying Equity is suspended from trading on Bursa Securities or such other Securities Exchanges prior to, and in connection with the delisting of such Underlying Equity, the Structured Warrants may if determined by the Issuer be automatically exercised and settled in cash without the Holder having to deliver a valid Exercise Form and without notice of automatic exercise being given by the Issuer to the Holder:

- (a) if the Cash Settlement Amount after deduction of the Exercise Expenses, if any, is greater than zero, the Issuer shall make payment of the Cash Settlement Amount to the relevant Holder; or
- (b) if the Cash Settlement Amount after deduction of the Exercise Expenses, if any, is equal to or less than zero, the Issuer shall not be obliged to make any payment to the relevant Holder and the relevant shall terminate and cease to be valid and the Issuer's obligations in respect of the shall terminate absolutely. For the avoidance of doubt, the Holder shall not be required to pay or top-up the Exercise Expenses, if any, as the case may be, where the Cash Settlement Amount after deduction of the Exercise Expenses, if any, is less than zero.

The Closing Price for the calculation of the Cash Settlement Amount (calculated in accordance with Condition 2) shall be the last quoted price of the Underlying Equity immediately before such events or determined in accordance with Condition 2.1.7(a)(1)(b) or 2.1.7(b), as the case may be, and the Issuer shall not be obliged to make any adjustment to the Exercise Price.

Provided that if there is a Market Disruption Event on the date immediately before such events ("**Set Date**"), the Closing Price shall be based on the Market Day immediately preceding the Market Disruption Event. If the preceding Market Day is also affected by the Market Disruption Event, then the Closing Price shall be determined by the Issuer on the Set Date as it reasonably deems fit and on the basis of the Issuer's good faith estimate the reference price and/or the exchange rate (if applicable) for that Set Date by determining the price of the Underlying Equity and/or the exchange rate (if applicable) based on the prevailing market conditions and other factors as the Issuer may consider relevant.

However, in the event the Underlying Equity is suspended or delisted (as the case may be) as a result of the Take-over Offer or the Compulsory Acquisition, the Closing Price for the calculation of the Cash Settlement Amount shall be as calculated above or the announced price for the Take-over Offer, whichever is lower.

10.2 Subject to the aforesaid, the Issuer may but shall not be obliged to make any adjustment to the terms and conditions of the Structured Warrants and the rights attaching to the Structured Warrants as it shall reasonably consider appropriate to ensure that the interests of the Holders generally are not materially prejudiced as a consequence of such events (without considering the individual circumstances of any Holder or the tax or other consequences that may result in any particular jurisdiction).

ANNEXURE I**PRINCIPAL TERMS OF THE DEED POLL (cont'd)****11 Liquidation, Dissolution or Winding-Up of the Underlying Company**

- 11.1 In the event of a liquidation, dissolution or winding-up of the Underlying Company or the appointment of a liquidator, receiver or administrator or analogous person under any applicable law in respect of the whole or substantially the whole of the Underlying Company's Assets, the Structured Warrants shall automatically be exercised and settled in cash without the Holder having to deliver a valid Exercise Form and without notice of automatic exercise being given by the Issuer to the Holder:
- (a) if the Cash Settlement Amount after deduction of the Exercise Expenses, if any, is greater than zero, the Issuer shall make payment of the Cash Settlement Amount to the relevant Holder; or
 - (b) if the Cash Settlement Amount after deduction of the Exercise Expenses, if any, is equal to or less than zero, the Issuer shall not be obliged to make any payment to the relevant Holder and the relevant Structured Warrants shall terminate and cease to be valid and the Issuer's obligations in respect of the Structured Warrants shall terminate absolutely. For the avoidance of doubt, the Holder shall not be required to pay or top-up the Exercise Expenses, if any, as the case may be, where the Cash Settlement Amount after deduction of the Exercise Expenses, if any, is less than zero.

The Closing Price for the calculation of the Cash Settlement Amount (calculated in accordance with Condition 2) shall, be the closing price of the Underlying Equity on the Market Day immediately before such events or determined in accordance with Condition 2.1.7(a)(1)(b) or 2.1.7(b), as the case may be, and the Issuer shall not be obliged to make any adjustment to the Exercise Price.

Provided that if there is a Market Disruption Event on the Set Date, the Closing Price shall be based on the preceding Market Day after the Market Disruption Event. If the preceding day is also affected by the Market Disruption Event, then the Closing Price shall be determined by the Issuer on the Set Date as it reasonably deems fit and on the basis of the Issuer's good faith estimate the reference price and/or the exchange rate (if applicable) for that Set Date by determining the price of the Underlying Equity and/or the exchange rate (if applicable) based on the prevailing market conditions and other factors as the Issuer may consider relevant.

- 11.2 Subject to the aforesaid, the Issuer may but shall not be obliged to make any adjustment to the terms and conditions of the Structured Warrants and the rights attaching to the Structured Warrants as it shall reasonably consider appropriate to ensure that the interests of the Holders generally are not materially prejudiced as a consequence of such events (without considering the individual circumstances of any Holder or the tax or other consequences that may result in any particular jurisdiction).

11A Takeover, Merger, Liquidation, Dissolution or Winding-Up of Issuer

- 11A.1 In the event of a take-over or a scheme of arrangement or any other form of reorganisation undertaken by the Issuer or any other events having similar effects on the rights of the Holders, the Issuer is entitled to deal with the Structured Warrants in such manner as it reasonably deems fit in the circumstances and with or without any adjustments to the rights attaching to the relevant Structured Warrants.
- 11A.2 In the event of a merger, amalgamation or reconstruction of the Issuer, the corporation, trust or other body into which the Issuer is merged, amalgamated or reconstructed shall assume all the liabilities and the obligations of the Issuer in respect of the Structured Warrants so that the rights of the Holders shall continue to exist and be enforceable to the same extent as provided by the Issuer under the Deed Poll.
- 11A.3 In the event of a liquidation, dissolution or winding-up of the Issuer or the appointment of a receiver or administrator or analogous person under any applicable law in respect of the whole or substantially the whole of the Issuer's Assets, the Structured Warrants remaining outstanding shall be deemed to be exercised on the Market Day immediately prior to the date of such liquidation, dissolution, winding-up or appointment as follows:
- (a) All unexercised Structured Warrants shall automatically be exercised and settled in cash without the Holders having to deliver a valid Exercise Form and without notice of automatic exercise being given by the Issuer to the Holders:

ANNEXURE I **PRINCIPAL TERMS OF THE DEED POLL** *(cont'd)*

- (i) if the Cash Settlement Amount after deduction of the Exercise Expenses, if any, is greater than zero, the Issuer shall make payment of the Cash Settlement Amount to the relevant Holder; or
- (ii) if the Cash Settlement Amount after deduction of the Exercise Expenses, if any, is equal to or less than zero, the Issuer shall not be obliged to make any payment to the relevant Holder and the relevant Structured Warrants shall terminate and cease to be valid and the Issuer's obligations in respect of the Structured Warrants shall terminate absolutely. For the avoidance of doubt, the Holder shall not be required to pay or top-up the Exercise Expenses, if any, as the case may be, where the Cash Settlement Amount after deduction of the Exercise Expenses, if any, is less than zero.

The closing price of the Underlying Equity on the Market Day immediately before the above events shall form the Closing Price for the calculation of the Cash Settlement Amount.

- (b) Notwithstanding the foregoing, if there is a Market Disruption Event on the Set Date, the Closing Price shall be based on the Market Day immediately preceding the Market Disruption Event. If the preceding Market Day is also affected by the Market Disruption Event, then the Closing Price shall be determined by the Issuer on the Set Date as it reasonably deems fit and on the basis of the Issuer's good faith estimate the reference price and/or the exchange rate (if applicable) for that Set Date by determining the price of the Underlying Equity and/or the exchange rate (if applicable) based on the prevailing market conditions and other factors as the Issuer may consider relevant.

12 Replacement of Structured Warrant Certificate

- 12.1 If the Structured Warrant Certificate which has been deposited with Bursa Depository is mutilated, defaced, lost, worn out, stolen or destroyed it shall be replaced by the Issuer at the registered office of the Structured Warrants Registrar on such terms as to evidence and indemnity or otherwise as the Issuer may require. All payment of such costs as may be incurred in connection therewith shall be borne by the Issuer. Mutilated, defaced, lost, worn, stolen or destroyed Structured Warrant Certificates shall be deemed cancelled.

13 Register, Transfer and Transmission

- 13.1 Each Holder registered in the Record of Depositors shall be entitled to all rights, benefits, powers and privileges and be subject to all liabilities, duties and obligations in respect of, or arising from the Structured Warrants, and shall be deemed and treated as the absolute owner of the relevant Structured Warrants, in accordance with the Central Depositories Act and the Rules of Bursa Depository, whether or not the Issuer shall be in default in respect of the Structured Warrants or any of the covenants contained herein and notwithstanding any notice of ownership or writing thereon or notice of any previous loss or theft of any Structured Warrants. The provisions of the Central Depositories Act, the Rules of Bursa Depository and the Issuer's constitution for the time being relating to the registration, transfer and transmission of shares and the fees payable thereon shall with necessary modifications apply to the registration, transfer and transmission of the legal ownership of the Structured Warrants, subject always to the provisions of this Condition 13 and Condition 2.
- 13.2 The entries made under the Record of Depositors shall be deemed to be the final record of all Depositors. No notice of any trust, express or implied, shall be entered upon the Record of Depositors otherwise than pursuant to an order of a court of competent jurisdiction or as required by law, and a Holder shall be deemed to be the beneficial owner of the Structured Warrants standing to the credit of his/its Securities Account, until such time as the Structured Warrants are duly transferred to another Holder and the name of the transferee is entered in the Record of Depositors.

14 Meetings of Holders

- 14.1 The procedure governing the convening and conduct of meetings of the Holders are set out in the Fourth Schedule to the Deed Poll.

ANNEXURE I PRINCIPAL TERMS OF THE DEED POLL (cont'd)**15 Notices**

15.1 Subject to Condition 15.2:

- (a) all notices to the Holders pertaining to the convening of meetings shall be made by way of notice published in at least one (1) English language national daily newspaper and announced through Bursa Securities; and
- (b) all other notices shall either be announced through the Bursa Securities or published in at least one (1) English language national daily newspaper.

15.2 A notice is deemed to have been given and served to the Holders on the date of announcement or publication as the case may be or, if announced or published more than once or on different dates, on the first date on which it is announced or published.

15.3 All notices effected in accordance with this Condition 15 shall be deemed to be effective in respect of all persons who become Holders after the date of the relevant notice.

15.4 For the avoidance of doubt, a notice shall not be required to be published or announced in respect of an event contemplated under Conditions 6, 8, 9, 10, 11 or 11A, as the case may be, if no adjustment to the rights of the Holders or amendment to the terms and conditions of the relevant Structured Warrants is made or to be made pursuant thereto.

16 Modification of rights

16.1 All or any of the rights for the time being attached to the Structured Warrants (other than the Exercise Price which a Holder is entitled to or the formulae for the adjustment of the Exercise Price or the Exercise Ratio or any other condition, which may be modified in accordance with the provisions set out elsewhere in these Conditions) may be altered or abrogated by the Issuer from time to time (whether or not the Issuer is being wound up), and the sanction of a Special Resolution passed at a meeting of the Holders held as aforesaid shall be necessary to effect such alteration or abrogation.

16.2 Notwithstanding Condition 16.1, the Issuer may without the consent of the Holders but in accordance with the terms of the Deed Poll, effect any modification to the Structured Warrants or the Deed Poll which, in the opinion of the Issuer, is:

- (a) not materially prejudicial to the interests of the Holders; or
- (b) of a formal, minor or technical nature; or
- (c) necessary or expedient to correct a manifest error, or to comply with mandatory provisions of law; or
- (d) necessary or expedient to facilitate scripless trading in or exercise of the Structured Warrants or payment by way of electronic funds transfer as approved by the relevant government or statutory authorities in respect of the Structured Warrants or to amend the restrictions on transfer or exercise of the Structured Warrants to comply with the requirements of or the concessions granted by any relevant government or statutory authorities.

Any such modification shall be binding on all Holders and shall be notified by the Issuer to them as soon as practicable thereafter in accordance with Condition 15 but in any event not later than twenty (20) Market Days from the date of such modification.

16.3 Notwithstanding Condition 16.1, the Issuer may, at any time and from time to time for the purpose of an issue of new Structured Warrants or a new Series of Structured Warrants through the Base Prospectus and without the consent or sanction of the Holders supplement the Deed Poll the terms and conditions of the new Structured Warrants or Series of Structured Warrants (as set out in the relevant Term Sheet), as the case may be. In the event such supplement to the Deed Poll shall affect the rights and interests of the Holders, the Issuer is to effect such supplement to the Deed Poll by notice to the Holders in accordance with Condition 15 and such supplement shall be binding on all Holders without any further action being required to be taken by the Issuer. For the avoidance of doubt, a Holder is deemed to have notice of all announcements (and their respective contents) made by the Issuer to Bursa Securities in respect of or affecting the Series of Structured Warrants held.

ANNEXURE I PRINCIPAL TERMS OF THE DEED POLL (cont'd)**17 Warrant Agency Agreement**

- 17.1 The Structured Warrants Registrar acts as agent of the Issuer and shall not assume any obligation or duty to or any relationship of agency or trust for the Holders except only as described in Condition 17.2.
- 17.2 The Warrant Agency Agreement contains provisions for the indemnification of the Structured Warrants Registrar. The Structured Warrants Registrar shall not be liable to any Holder in respect of any losses, liabilities, costs, claims, actions or demands which such Holder may suffer or incur or allege to have suffered or incurred as a result of or in connection with the exercise or non-exercise of any Structured Warrants Registrar's powers, discretions and/or duties. The Structured Warrants Registrar may:
- (a) in the exercise of its powers, discretions and/or duties, act on the advice or opinion of, or any certificate or information obtained in good faith from, any lawyer, valuer, accountant, banker, broker, securities company or other expert whether obtained by the Issuer, the relevant Structured Warrants Registrar or otherwise (which advice, opinion, certificate or information may be sent or obtained by letter, email, telex, telegram, cable or facsimile device) and the Structured Warrants Registrar shall not be liable for any loss occasioned by acting in good faith on any such advice, opinion, certificate or information unless there are reasonable grounds for concluding that the same may be forged or otherwise not authentic or containing some errors with respect to content, delivery or transmission;
 - (b) receive and retain without liability to account, such fee or other remuneration as may from time to time be agreed between the Issuer and the Structured Warrants Registrar; and
 - (c) enter into or be interested in any contract or financial or other transaction or arrangement with the Issuer or any person or body corporate associated with the Issuer in connection therewith to receive and retain, without liability to account any profit, fee, remuneration or other benefit received thereby or in connection therewith.

The Structured Warrants Registrar does not act as the agent of any Holder and therefore owes no fiduciary duty to any Holder in arriving at its calculations and determinations.

18 Exclusion of equities

- 18.1 Subject to the Central Depositories Act, the Rules of Bursa Depository, the Deed Poll, or these Conditions, no person shall be recognised by the Issuer as holding any Structured Warrants upon any trust, and the Issuer shall not be bound by or compelled in any way to recognise any equitable, contingent, future or partial interest in any Structured Warrant, or any interest in any fractional part of a Structured Warrant, or (except only as by these presents or by law otherwise provided) any other right in respect of any Structured Warrants, except an absolute right to the entirety thereof in the registered holder.

19 Force Majeure

- 19.1 If the Issuer determines that, for reasons beyond the Issuer's control, the performance of the Issuer's obligations under the Structured Warrants has become illegal or impractical in whole or in part for any reason, or the Issuer determines that, for reasons beyond the Issuer's control, it is no longer legal or practical for the Issuer to maintain the Issuer's hedging arrangements with respect to the Structured Warrants for any reason, the Issuer may in the Issuer's discretion and without obligation terminate the Structured Warrants early by giving notice to the Holders in accordance with Condition 15.

20 Governing law

- 20.1 The Structured Warrants and the Deed Poll are governed by and shall be construed in accordance with the laws of Malaysia. The Issuer and the Holders irrevocably agree that with respect to any proceedings in Malaysia in connection with any matter or issue relating to the Deed Poll and these Conditions, they shall be bound by the decision, ruling or order of the Malaysian Court.

(the remainder of this page is intentionally left blank)

PART 4

CONDITIONS OF THE CASH-SETTLED SINGLE INDEX CALL OR PUT WARRANTS

1 General, Nature, Form, Transfer, Administration and Status of Structured Warrants

- 1.1 The Structured Warrants comprise **American or European style non-collateralised cash-settled call or put warrants over a single index** to be issued from time to time by the Issuer through the Base Prospectus and subject to, and with the benefit of the Deed Poll referred to on the face of the Structured Warrant Certificate and these Conditions. The Exercise Rights entitle the Holder of each Structured Warrant for each Series of Structured Warrants issued or to be issued, subject to the Deed Poll and in accordance with these Conditions, upon valid exercise thereof, to the Cash Settlement Amount calculated in accordance with Condition 2. Certain statements in these Conditions are summaries of and are subject to the detailed provisions of the Deed Poll and in the event of any inconsistency between a provision contained in these Conditions and a provision contained in the Deed Poll, the provisions in the Deed Poll shall prevail. The Issuer has entered into a Warrant Agency Agreement with the Structured Warrants Registrar. Copies of the Deed Poll and the Warrant Agency Agreement are available for inspection at the registered office of the Issuer, being at the date hereof at 22nd Floor, Bangunan AmBank Group, No. 55 Jalan Raja Chulan, 50200 Kuala Lumpur, Malaysia. The Holders for the time being of the Structured Warrants and whose names appear on the Record of Depositors are all entitled to the benefit of, bound by, and deemed to have notice of, all the provisions of the Deed Poll and the Warrant Agency Agreement. Further, each Holder acknowledges it has, where necessary, consulted its stockbroker, solicitor or other adviser before investing in the Structured Warrants and none of the Issuer or its directors or employees may be construed as investment adviser or agent of, or owe any fiduciary duty to the Holder. **For the purposes of this Part 4, the term "Structured Warrants" shall refer to the American or European style non-collateralised cash-settled call or put warrants over a single index.**
- 1.2 Subject to the Central Depositories Act, the Rules of Bursa Depository, the Deed Poll, the relevant applicable rules and regulations and these Conditions:
- (a) each Structured Warrant is an option which confers on the Holder the Exercise Rights which require the Issuer to pay the Cash Settlement Amount to the Holder in accordance with these Conditions; and
 - (b) the Structured Warrants are issued in registered form, serially numbered and are a Prescribed Security to be admitted to the Official List. The Structured Warrants are represented by a global/jumbo certificate issued to Bursa Depository or its nominee who holds the same as bare trustee on behalf of the Holders, and deposited with Bursa Depository in or substantially in the form set out in the First Schedule to the Deed Poll as the same may from time to time be modified in accordance with the Deed Poll.
- 1.3 Subject to all information provided by the subscriber for the Structured Warrants to the Issuer being complete and consistent with the records of Bursa Depository, the Issuer shall within seven (7) Market Days from the date of allotment of the Structured Warrants, cause and procure the Structured Warrants Registrar to notify Bursa Depository of the names of the Holders together with such particulars as may be required by Bursa Depository for the purpose of making appropriate entries in the Securities Account of the respective Holder, request Bursa Depository to credit the Securities Account of the Holders with the applicable Structured Warrants and shall deliver to Bursa Depository the Structured Warrant Certificate registered in the name of Bursa Depository or its nominee company in such manner as may be prescribed by the Rules of Bursa Depository or agreed with Bursa Depository. If, at any time, the information provided by the Holders for the Structured Warrants is incorrect or inaccurate or inconsistent with the records of Bursa Depository, the Issuer reserves the right and without any obligation whatsoever to the Holders, to accept, reject or otherwise deal with the Structured Warrants in such manner as it reasonably deems fit in the circumstances. The Holders are not entitled to any physical warrant certificates.
- 1.4 Subject to the provisions of the Central Depositories Act and the Rules of Bursa Depository, the registration and subsequent administration of Structured Warrants shall be in the manner set forth in the Deed Poll and the Warrant Agency Agreement. It is hereby acknowledged that the Issuer shall be entitled to appoint registrars for the registration and administration of the Structured Warrants. The Issuer hereby confirms that it shall/has appointed the Structured Warrants Registrar

ANNEXURE I **PRINCIPAL TERMS OF THE DEED POLL** *(cont'd)*

for the purpose stipulated hereof, who shall perform such duties as required by the Issuer under the Deed Poll.

- 1.5 The Holders may transfer the Structured Warrants in the manner prescribed under the Central Depositories Act and the Rules of Bursa Depository. Structured Warrants shall be issued in board lots of one hundred (100) warrants or such other board lot as permitted by the SC and/or Bursa Securities.
- 1.6 The Structured Warrants and the settlement obligation of the Issuer in respect of the Structured Warrants represent general and unsecured contractual obligations of the Issuer and of no other person which rank, and shall rank, equally among themselves and without preference in all respects, subject to such exceptions as may from time to time exist under applicable law or the Deed Poll, with the other existing and future unsecured and unsubordinated obligations of the Issuer.
- 1.7 The Structured Warrants do not confer on the Holders any right to acquire or dispose of equities or other securities, including the equities in the companies constituting the Underlying Index and the Issuer is not under any obligation whatsoever to purchase, hold or deliver such equities or other securities, or any rights and benefits attaching thereto.
- 1.8 The Holders of Structured Warrants are entitled to the Cash Settlement Amount in accordance with Condition 2.

2 Exercise of the Structured Warrants**2.1 American style Structured Warrants**

2.1.1 The Structured Warrants may be exercised in the manner as set out in Condition 2.1.2 at anytime from the date of issue up to the Expiry Date. In the event the date whereby the Exercise Form is delivered is not a Market Day, then it shall be deemed to be exercised on the next following Market Day.

2.1.2 In order to invoke the Exercise Rights within the Exercise Period, a Holder must complete and sign the Exercise Form (which shall be made available by the Structured Warrants Registrar in any manner as may be stipulated by Bursa Securities or such other relevant authority) and deliver the same on a Market Day between 9.00 a.m. to 5.00 p.m. to the Structured Warrants Registrar who shall acknowledge receipt by stamping the date and time of receipt on the Exercise Form in respect of which the Structured Warrants are being exercised.

Provided always that:

- (a) in every case compliance must also be made with the requirements set out in the Exercise Form and other prevailing statutory requirements for the time being applicable;
- (b) the Holder shall, if so required by the Structured Warrants Registrar, furnish such evidence, if any, as the Structured Warrants Registrar or the directors of the Issuer may require to determine the due execution of the Exercise Form by or on behalf of the Holder exercising the same. Once a valid Exercise Form is duly delivered by the Holder to the Structured Warrants Registrar the exercise of such Exercise Rights shall be irrevocable save with the consent of the directors of the Issuer; and
- (c) where the Holder does not comply with the procedures or restrictions or conditions relating to the exercise of the Structured Warrants, the Exercise Form and any documents received shall be returned to such Holder by ordinary post to the Holder's address recorded in the Record of Depositors at the risk of the Holder.
- 2.1.3 Subject to notification by the Structured Warrants Registrar of fulfilment of the preconditions by the Holder to validly exercise the Structured Warrants as set out in Condition 2.1.2 within three (3) Market Days from the Exercise Date and the absence of a Settlement Disruption Event, the Issuer shall, within seven (7) Market Days from the Exercise Date or such other period as may be prescribed by the Bursa Securities or such other relevant authority, pay to the relevant Holder, the Cash Settlement Amount calculated as set out below less Exercise Expenses, if any.

ANNEXURE I PRINCIPAL TERMS OF THE DEED POLL (cont'd)

For call warrants:

$$\text{Cash Settlement Amount} = \text{Number of Structured Warrants} \times (\text{Closing Level}^{(1)} - \text{Exercise Level}^{(2)}) \times \frac{1}{\text{Exercise Ratio}^{(2)}} \times \text{Multiplier}^{(3)} \times \text{Settlement Exchange Rate (if applicable)}$$

For put warrants:

$$\text{Cash Settlement Amount} = \text{Number of Structured Warrants} \times (\text{Exercise Level}^{(2)} - \text{Closing Level}^{(1)}) \times \frac{1}{\text{Exercise Ratio}^{(2)}} \times \text{Multiplier}^{(3)} \times \text{Settlement Exchange Rate (if applicable)}$$

(1) The Closing Level shall be calculated by reference to either:

(a) In the event a valid Exercise Form is received in accordance with Condition 2.1.2 by the Structured Warrants Registrar:

(i) before 12.30 p.m. on any Market Day other than on the Expiry Date, the exercise of the Structured Warrants shall be deemed to have been made on that Market Day and in such instance the Market Day of receipt of the Exercise Form shall be the Exercise Date and the Valuation Date and the Closing Level shall be the closing level of the Underlying Index on such Valuation Date; or

(ii) on or after 12.30 p.m. on any Market Day other than on the Expiry Date, the exercise of the Structured Warrants shall be deemed to have been made on the Market Day immediately following the Market Day of receipt of the Exercise Form and in such instance the Market Day immediately following the Market Day of receipt of the Exercise Form shall be the Exercise Date and the Valuation Date and the Closing Level shall be the closing level of the Underlying Index on such Valuation Date. For the avoidance of doubt, if a valid Exercise Form is received on or after 12.30 p.m. on a Market Day immediately preceding the Expiry Date, the exercise of the Structured Warrants shall be deemed to have been made on the Expiry Date and in such instance the Closing Level shall be the Expiry Date Closing Level (as defined below) of the Underlying Index; or

(iii) on the Expiry Date, the Closing Level shall be the Expiry Date Closing Level (as defined below) of the Underlying Index,

and as specified in the relevant Term Sheet and subject to the Market Disruption Event provision below.

(b) In the event of any exercise of the Structured Warrants on the Expiry Date, the Closing Level shall be calculated by reference to either:

(i) the closing level of the Underlying Index on the Market Day immediately before the Expiry Date; or

(ii) the final settlement price for settling the corresponding spot-month index future contracts on the Expiry Date or on the market day immediately before the Expiry Date, if the contract is settled in a time zone that is behind Malaysian time; or

(iii) the average of the closing levels of the Underlying Index for the five (5) Market Days prior to and including the Market Day immediately before the Expiry Date,

and as specified in the relevant Term Sheet ("**Expiry Date Closing Level**") and subject to the Market Disruption Event provision below.

ANNEXURE I**PRINCIPAL TERMS OF THE DEED POLL** (cont'd)

If on the relevant date the Underlying Index Sponsor has not published the Underlying Index for the purpose of calculating the Closing Level, the Closing Level will be the closing level of the Underlying Index on the Market Day immediately before the relevant date (subject to the Market Disruption Event provision below).

- (c) If a Market Disruption Event, or a public holiday unexpected by the Issuer occurs on any of the five (5) Market Days described in sub-Condition (1)(b)(iii) above, the valuation period applicable and the Closing Level shall be as determined by the Issuer as it reasonably deems fit.

In regards to sub-condition (1)(b)(i) above, if there is a Market Disruption Event on the Valuation Date, the Valuation Date shall be the next following Market Day after the Market Disruption Event. If the Market Disruption Event continues to occur up to the eighth (8th) Business Day following the original Valuation Date, then the Valuation Date shall be:

- (i) that eighth (8th) Business Day; and
- (ii) the Issuer shall determine as it reasonably deems fit and on the basis of the Issuer's good faith estimate the reference level and/or the exchange rate (if applicable) for that Valuation Date by determining the level of the Underlying Index and/or the exchange rate (if applicable) based on the prevailing market conditions and other factors as the Issuer may consider relevant.

In regards to sub-Conditions (1)(b)(ii) above, if there is a Market Disruption Event on the scheduled Expiry Date or the final settlement price for settling the corresponding spot-month index futures contracts scheduled to expire on the scheduled Expiry Date is otherwise unavailable on that date, the Expiry Date will be postponed until such final settlement price for settling the corresponding spot-month index futures contracts is published.

- (2) The Exercise Level and/or Exercise Ratio shall be subject to such adjustments as may be necessary as provided in Condition 6.
- (3) The Multiplier shall be specified in the relevant Term Sheet.

2.1.4 In the event that the Cash Settlement Amount after deduction of the Exercise Expenses, if any, is equal to or less than zero, the Issuer shall not be obliged to make any payment to the relevant Holder, and the Structured Warrants exercised shall thereafter become void and cease to have the Exercise Rights and the Issuer's obligations in respect of the Structured Warrants shall terminate absolutely. For the avoidance of doubt, the Holder shall not be required to pay or top-up the Exercise Expenses, if any, as the case may be, where the Cash Settlement Amount after deduction of the Exercise Expenses, if any, is less than zero.

2.1.5 If the Structured Warrants is not earlier exercised, the Structured Warrants shall be deemed automatically exercised at 5.00 p.m. on the Expiry Date without the Holders having to deliver a valid Exercise Form to the Structured Warrants Registrar and without notice of automatic exercise being given by the Issuer to the Holders.

2.1.6 Upon automatic exercise of the Structured Warrants on the Expiry Date in accordance with Condition 2.1.5 above, if the Cash Settlement Amount after deduction of the Exercise Expenses, if any:

- (a) is greater than zero, in the absence of a Settlement Disruption Event, payment shall be made by the Issuer to the relevant Holders within seven (7) Market Days from the Expiry Date, and the Issuer's obligations in respect of the Structured Warrants shall terminate absolutely; or
- (b) is equal to or less than zero, the Structured Warrants shall terminate and cease to be valid and the Issuer's obligations in respect of the Structured Warrants shall terminate absolutely. For the avoidance of doubt, the Holder shall not be required

ANNEXURE I PRINCIPAL TERMS OF THE DEED POLL (cont'd)

to pay or top-up the Exercise Expenses, if any, as the case may be, where the Cash Settlement Amount after deduction of the Exercise Expenses, if any, is less than zero.

2.2 European style Structured Warrants

2.2.1 The Structured Warrants shall be automatically exercised at 5.00 p.m. on the Expiry Date if the Cash Settlement Amount calculated in Condition 2.2.2 after deduction of the Exercise Expenses, if any, is greater than zero (without the Holder having to deliver a valid Exercise Form and without notice of automatic exercise being given by the Issuer to the Holders). If the Expiry Date is not a Market Day then it shall be deemed to be exercised on the next following Market Day. The Structured Warrants will automatically terminate and cease to be valid at 5.00 p.m. on the Expiry Date if the Cash Settlement Amount after deduction of the Exercise Expenses, if any, is equal to or less than zero and the Issuer's obligations in respect of the Structured Warrants shall terminate absolutely. For the avoidance of doubt, the Holder shall not be required to pay or top-up the Exercise Expenses, if any, as the case may be, where the Cash Settlement Amount after deduction of the Exercise Expenses, if any, is less than zero.

2.2.2 The Issuer shall in the absence of a Settlement Disruption Event, within seven (7) Market Days from the Expiry Date or such other period as may be prescribed by Bursa Securities or such other relevant authority, pay to the relevant Holder, the Cash Settlement Amount, calculated as set out below less Exercise Expenses, if any:

For call warrants:

$$\text{Cash Settlement Amount} = \text{Number of Structured Warrants} \times (\text{Closing Level}^{(1)} - \text{Exercise Level}^{(2)}) \times \frac{1}{\text{Exercise Ratio}^{(2)}} \times \text{Multiplier}^{(3)} \times \text{Settlement Exchange Rate (if applicable)}$$

For put warrants:

$$\text{Cash Settlement Amount} = \text{Number of Structured Warrants} \times (\text{Exercise Level}^{(2)} - \text{Closing Level}^{(1)}) \times \frac{1}{\text{Exercise Ratio}^{(2)}} \times \text{Multiplier}^{(3)} \times \text{Settlement Exchange Rate (if applicable)}$$

(1) (a) The Closing Level on the Expiry Date shall be calculated by reference to either:

- (i) the closing level of the Underlying Index on the Market Day immediately before the Expiry Date; or
- (ii) the final settlement price for settling the corresponding spot-month index future contracts on the Expiry Date; or
- (iii) the average of the closing levels of the Underlying Index for the five (5) Market Days prior to and including the Market Day immediately before the Expiry Date,

and as specified in the relevant Term Sheet.

If on the relevant date the Underlying Index Sponsor has not published the Underlying Index for the purpose of calculating the Closing Level, the Closing Level will be the closing level of the Underlying Index on the Market Day immediately before the relevant date (subject to the Market Disruption Event provision below).

(b) If a Market Disruption Event, or a public holiday unexpected by the Issuer occurs on any of the five (5) Market Days described in sub-Condition (1)(a)(iii) above, the valuation period applicable and the Closing Level shall be as determined by the Issuer as it reasonably deems fit.

In regards to sub-Condition (1)(a)(i) above, if there is a Market Disruption Event on the Valuation Date, the Valuation Date shall be the next following Market Day after the Market Disruption Event. If the Market Disruption Event continues to occur up to the eighth (8th) Business Day following the original Expiry Date, then the Expiry Date shall be:

- (i) that eighth (8th) Business Day; and
- (ii) the Issuer shall determine as it reasonably deems fit and on the basis of the Issuer's good faith estimate the reference level and/or the exchange rate (if applicable) for that Expiry Date by determining the level of the Underlying Index and/or the exchange rate (if applicable) based on the prevailing market conditions and other factors as the Issuer may consider relevant.

In regards to sub-Conditions (1)(a)(ii) above, if there is a Market Disruption Event on the scheduled Expiry Date or the final settlement price for settling the corresponding spot-month index futures contracts scheduled to expire on the scheduled Expiry Date is otherwise unavailable on that date, the Expiry Date will be postponed until such final settlement price for settling the corresponding spot-month index futures contracts is published.

- (2) The Exercise Level and/or Exercise Ratio shall be subject to such adjustments as may be necessary as provided in Condition 6.
- (3) The Multiplier shall be specified in the relevant Term Sheet.

2.2.3 In the event that the Cash Settlement Amount after deduction of the Exercise Expenses, if any, is equal to or less than zero on the Expiry Date, the Structured Warrants shall terminate on the Expiry Date and cease to be valid and the Issuer's obligations in respect of the Structured Warrants shall terminate absolutely. For the avoidance of doubt, the Holder shall not be required to pay or top-up the Exercise Expenses, if any, as the case may be, where the Cash Settlement Amount after deduction of the Exercise Expenses, if any, is less than zero.

- 2.3 (a) The Cash Settlement Amount less the Exercise Expenses, if any, shall be made by way of cheque drawn in favour of the Holder to be delivered by ordinary post to the Holder's address last recorded in the Record of Depositors at the Holder's own risk or by way of electronic transfer of funds to the bank account of the Holder, the details of which are provided by Bursa Depository to the Issuer at the request of the Issuer. Where the Issuer makes a payment to a Holder pursuant to the terms of Conditions 2.1 or 2.2, the amount of such payment arising from the exercise of the Structured Warrants shall be final and conclusive and the Issuer shall be discharged from its obligation upon making such payment thereof in accordance with these Conditions.
- (b) The Cash Settlement Amount less the Exercise Expenses, if any, shall be calculated and be payable in Settlement Currency and rounded down to the nearest two (2) decimal points. All determinations made by the Issuer pursuant to Conditions 2.1 or 2.2 shall be final and conclusive and binding on the Holders.
- (c) The Holder is to bear all Exercise Expenses, if any, in relation to the exercise of Structured Warrants and on exercise of the Structured Warrants the Issuer shall be irrevocably authorised by the Holder to deduct all Exercise Expenses, if any, from the Cash Settlement Amount.
- (d) If as a result of a Settlement Disruption Event, it is not possible for the Issuer to make payment on the original Settlement Date, the Issuer shall use its reasonable endeavours to procure payment as soon as practicable after the original Settlement Date. The Issuer shall not be liable to the Holder for any interest in respect of the amount due or any loss or

ANNEXURE I **PRINCIPAL TERMS OF THE DEED POLL** (cont'd)

damage that such Holder may suffer as a result of the existence of the Settlement Disruption Event.

- 2.4 The Issuer shall not allow the Holder to exercise the Exercise Rights unless the Structured Warrants are or have been designated as "free securities" in accordance with the Rules of Bursa Depository.
- 2.5 The Issuer declares that approval shall be sought from Bursa Securities for the admission of the Structured Warrants to the Official List and for the listing of and quotation for the Structured Warrants on Bursa Securities.
- 2.6 All questions as to the validity, form, eligibility (including time of receipt) and acceptance of Exercise Form shall be resolved by the Structured Warrants Registrar a manner as it reasonably deems fit, whose determination shall be final and binding on the Issuer and the Holder. The Structured Warrants Registrar is entitled to reject any Exercise Form that is not in proper form or the acceptance of which may, in the view of counsel for the Structured Warrants Registrar be unlawful. The Structured Warrants Registrar also reserves the right, subject to applicable law, to waive any irregularities. The interpretation of the Structured Warrants Registrar of the terms and conditions of exercise of the Structured Warrants shall be final and binding on the Issuer and the Holder. Unless waived, any irregularities in connection with the Exercise Form must be rectified by such time, as the Structured Warrants Registrar shall determine. The Structured Warrants Registrar shall not be under any duty to give notification of any irregularities in such Exercise Form and shall not incur liabilities for failure to give such notification. The Exercise Form shall not be considered to have been validly delivered until such irregularities have been rectified and waived.
- 2.7 The initial Structured Warrants Registrar and its specified offices are stated in the Deed Poll. The Issuer reserves the right at any time to terminate the appointment of the Structured Warrants Registrar. Prior written notice of any termination, appointment of Structured Warrants Registrar, resignation of the Structured Warrants Registrar or any changes in any of the specified offices of the relevant Structured Warrants Registrar shall be given to the Holders in accordance with Condition 12 and such prior notice shall be given to the Holders not more than sixty (60) days and less than thirty (30) days of such termination, appointment, resignation or change.
- 2.8 In respect of each Structured Warrant in which Exercise Rights have been exercised, the Issuer shall instruct or procure the Structured Warrants Registrar to instruct Bursa Depository to debit the appropriate number of Structured Warrants in respect of which Exercise Rights have been exercised from the Securities Account of such Holder. The Issuer shall be entitled at any time on or after the Expiry Date, to demand that Bursa Depository deliver to the Issuer the Structured Warrant Certificates and thereafter cancel or cause the cancellation of the Structured Warrant Certificates.
- 2.9 The Structured Warrants subject to the Exercise Rights which have been exercised in accordance with the Deed Poll shall cease to exist and all obligations of the Issuer in respect of those Structured Warrants shall terminate absolutely following payment of the amount (if any) referred to in this Condition 2.

3 Exercise Rights and Suspension

- 3.1 Upon and subject to the provisions of the Central Depositories Act, the Rules of Bursa Depository and the Deed Poll, the Holder whose name as stated in the Record of Depositors shall have the right at any time during the Exercise Period to invoke its Exercise Rights at the Exercise Level subject to adjustments in accordance with Condition 6.
- 3.2 The Structured Warrants shall, subject to any directions, order or notice from any relevant regulatory authority and any request for suspension by the Issuer which is not rejected by any such relevant regulatory authority, continue to be traded notwithstanding that the trading of the options or futures relating to the relevant Underlying Index on any options or futures exchanges may have been suspended. Any such suspension shall not preclude the Holder from exercising the Exercise Rights.
- 3.3 The Issuer shall notify the Holders of the Expiry Date at least one (1) month prior to the Expiry Date or such other period as may be specified by the relevant authority. Such notice shall be given in accordance with Condition 12 stating the Expiry Date and treatment of the Structured Warrants which are not exercised.

ANNEXURE I PRINCIPAL TERMS OF THE DEED POLL (cont'd)**4 Deposit and Forfeiture of Unclaimed Amount**

- 4.1 In the event that the Issuer makes the Cash Settlement Amount to any Holder under Condition 2 and such Holder does not present the cheque for payment within six (6) months from the date of the cheque, the Issuer shall at any time thereafter deal with the said monies in accordance and in compliance with, the requirements of the Unclaimed Moneys Act 1965 (Act 370) (revised 1989) of Malaysia.

5 Designation of Structured Warrants set out in the Exercise Form

- 5.1 Subject to the approval of Bursa Depository and/or other relevant authority, the Issuer reserves all rights to instruct Bursa Depository and/or other relevant authority to designate the Structured Warrants held in the relevant Securities Account of a Holder which the Holder has purportedly exercised by submitting an Exercise Form to the Issuer and/or the Structured Warrants Registrar, in order for Bursa Depository and/or the relevant authority to prohibit the Holder from trading on the exchange the designated Structured Warrants after the aforesaid exercise. The Issuer's right to instruct Bursa Depository and/or the relevant authority shall be independent of whether the exercise is valid or otherwise, provided that the amount of Structured Warrants so designated by Bursa Depository and/or the relevant authority do not exceed the amount set out in such Exercise Form.

6 Adjustment of the Underlying Index, Exercise Level and/or Exercise Ratio

6.1 Adjustments

Subject to the Conditions as hereinafter provided and the Deed Poll, the Underlying Index of the relevant Structured Warrants shall from time to time be adjusted in accordance with the following provisions:

- (a) Successor for the Underlying Index Sponsor calculates and reports on the Underlying Index

If a relevant Underlying Index is:

- (i) not calculated and announced by the Underlying Index Sponsor but is calculated and published by a successor to the Underlying Index Sponsor (the "**Successor Underlying Index Sponsor**") acceptable to the Issuer; or
- (ii) replaced by a successor index using, in the determination of the Issuer, the same or a substantially similar formula for and method of calculation as used in the calculation of the Underlying Index,

then in each case, that underlying index ("**Successor Index**") shall be deemed to be the Underlying Index.

- (b) Modification and Cessation of Calculation of Underlying Index

If:

- (i) on or prior to the Valuation Date, the Underlying Index Sponsor or (if applicable) the Successor Underlying Index Sponsor makes or announces that they shall make a material change in the formula for or the method of calculating the Underlying Index or in any other way materially modifies the Underlying Index (other than a modification prescribed in that formula or method to maintain the Underlying Index in the event of changes in constituent securities and other capitalisation and routine events) or cancels or announces the cancellation of the Underlying Index and no Successor Index exists; or
- (ii) on the Valuation Date, the Underlying Index Sponsor or the Successor Underlying Index Sponsor fails to calculate and publish the Underlying Index (other than as a result of a Market Disruption Event),

then the Issuer may determine the reference level using, in lieu of a published level for the Underlying Index, the level for the Underlying Index as at that Exercise Date as determined by the Issuer in accordance with the formula for and method of calculating the Underlying Index last in effect prior to that change, modification, cancellation or failure, but using only securities that constituted the Underlying Index immediately prior to that change,

ANNEXURE I PRINCIPAL TERMS OF THE DEED POLL (cont'd)

modification, cancellation or failure (other than those securities that constituted the Underlying Index which have since ceased to be listed on or quoted by the relevant Securities Exchange).

(c) Correction of Closing Level

In the event that the Closing Level published by the Underlying Index Sponsor or the Successor Underlying Index Sponsor which is utilised for any calculation or determination made under the Structured Warrants is subsequently corrected, the Issuer will, as it reasonably deems fit, adjust the terms of the Structured Warrants to account for such correction provided that such correction is published and made available to the public by the Underlying Index Sponsor or the Successor Underlying Index Sponsor during a period following original publication equal in duration to the period in which a trade in futures or options contracts relating to the Underlying Index on the relevant Securities Exchange would customarily settle according to the rules of such Securities Exchange, or if there are multiple Securities Exchanges in respect of the Underlying Index, the longest such period, and further provided, that such publication of such correction is made sufficiently in advance of the Settlement Date.

(d) Notice of Determinations

All determinations made by the Issuer pursuant hereto shall be conclusive and binding on the Holders. The Issuer shall give, or procure that there is given, notice as soon as practicable of any adjustment and of the date from which such adjustment is effective by notification to the Holders in accordance with Condition 12.

6.2 Notwithstanding the foregoing, no adjustments shall be made to the Exercise Ratio and/or Exercise Level if such adjustments would amount to less than two percent (2%) of the Exercise Ratio and/or Exercise Level being changed.

6.3 Any adjustment made pursuant to Conditions 6.1 and 6.2 shall be final and binding on the Holders save in the case of manifest error. Notice of such adjustments or amendments shall be given to the Holders as soon as practicable thereafter in accordance with Condition 12 and in any event within five (5) Market Days of the adjustment being made.

7 Restrictions to Protect Rights of Holders

7.1 As from the date of the issue of the Structured Warrants and for so long as any of the Structured Warrants remain exercisable, the Issuer shall have arrangements in place to ensure, for the benefit of the Holders that it is able to satisfy in full the exercise of all the Structured Warrants for the time being outstanding.

8 Takeover, Merger, Liquidation, Dissolution or Winding-Up of Issuer

8.1 In the event of a take-over or a scheme of arrangement or any other form of reorganisation undertaken by the Issuer or any other events having similar effects on the rights of the Holders, the Issuer is entitled to deal with the Structured Warrants in such manner as it reasonably deems fit in the circumstances and with or without any adjustments to the rights attaching to the relevant Structured Warrants.

8.2 In the event of a merger, amalgamation or reconstruction of the Issuer, the corporation, trust or other body into which the Issuer is merged, amalgamated or reconstructed shall assume all the liabilities and the obligations of the Issuer in respect of the Structured Warrants so that the rights of the Holders shall continue to exist and be enforceable to the same extent as provided by the Issuer under the Deed Poll.

8.3 In the event of a liquidation, dissolution or winding-up of the Issuer or the appointment of a receiver or administrator or analogous person under any applicable law in respect of the whole or substantially the whole of the Issuer's Assets, the Structured Warrants remaining outstanding shall be deemed to be exercised on the Market Day immediately prior to the date of such liquidation, dissolution, winding-up or appointment as follows:

ANNEXURE I PRINCIPAL TERMS OF THE DEED POLL (cont'd)

- (a) All unexercised Structured Warrants shall automatically be exercised without the Holders having to deliver a valid Exercise Form and without notice of automatic exercise being given by the Issuer to the Holders:
- (i) if the Cash Settlement Amount after deduction of the Exercise Expenses, if any, is greater than zero, the Issuer shall make payment of the Cash Settlement Amount to the relevant Holder; or
 - (ii) if the Cash Settlement Amount after deduction of the Exercise Expenses, if any, is equal to or less than zero, the Issuer shall not be obliged to make any payment to the relevant Holder and the relevant Structured Warrants shall terminate and cease to be valid and the Issuer's obligations in respect of the Structured Warrants shall terminate absolutely. For the avoidance of doubt, the Holder shall not be required to pay or top-up the Exercise Expenses, if any, as the case may be, where the Cash Settlement Amount after deduction of the Exercise Expenses, if any, is less than zero.

The closing level of the Underlying Index on the Market Day immediately before the above events shall form the Closing Level for the calculation of the Cash Settlement Amount for the Structured Warrants.

- (b) Notwithstanding the foregoing, if there is a Market Disruption Event on the date immediately before the above events ("**Set Date**"), the Closing Level shall be based on the Market Day immediately preceding the Market Disruption Event. If the preceding Market Day is also affected by the Market Disruption Event, then the Closing Level shall be determined by the Issuer on the Set Date as it reasonably deems fit and on the basis of the Issuer's good faith estimate the reference level and/or the exchange rate (if applicable) for that Set Date by determining the level of the Underlying Index and/or the exchange rate (if applicable) based on the prevailing market conditions and other factors as the Issuer may consider relevant.

9 Replacement of Structured Warrant Certificate

- 9.1 If the Structured Warrant Certificate which has been deposited with Bursa Depository is mutilated, defaced, lost, worn out, stolen or destroyed it shall be replaced by the Issuer at the registered office of the Structured Warrants Registrar on such terms as to evidence and indemnity or otherwise as the Issuer may require. All payment of such costs as may be incurred in connection therewith shall be borne by the Issuer. Mutilated, defaced, lost, worn, stolen or destroyed Structured Warrant Certificates shall be deemed cancelled.

10 Register, Transfer and Transmission

- 10.1 Each Holder registered in the Record of Depositors shall be entitled to all rights, benefits, powers and privileges and be subject to all liabilities, duties and obligations in respect of, or arising from the Structured Warrants, and shall be deemed and treated as the absolute owner of the relevant Structured Warrants, in accordance with the Central Depositories Act and the Rules of Bursa Depository, whether or not the Issuer shall be in default in respect of the Structured Warrants or any of the covenants contained herein and notwithstanding any notice of ownership or writing thereon or notice of any previous loss or theft of any Structured Warrants. The provisions of the Central Depositories Act, the Rules of Bursa Depository and the Issuer's constitution for the time being relating to the registration, transfer and transmission of shares and the fees payable thereon shall with necessary modifications apply to the registration, transfer and transmission of the legal ownership of the Structured Warrants, subject always to the provisions of this Condition 10 and Condition 2.
- 10.2 The entries made under the Record of Depositors shall be deemed to be the final record of all Depositors. No notice of any trust, express or implied, shall be entered upon the Record of Depositors otherwise than pursuant to an order of a court of competent jurisdiction or as required by law, and a Holder shall be deemed to be the beneficial owner of the Structured Warrants standing to the credit of his/its Securities Account, until such time as the Structured Warrants are duly transferred to another Holder and the name of the transferee is entered in the Record of Depositors.

ANNEXURE I PRINCIPAL TERMS OF THE DEED POLL (cont'd)**11 Meetings of Holders**

- 11.1 The procedure governing the convening and conduct of meetings of the Holders are set out in the Fourth Schedule to the Deed Poll.

12 Notices

- 12.1 Subject to Condition 12.2:

- (a) all notices to the Holders pertaining to the convening of meetings shall be made by way of notice published in at least one (1) English language national daily newspaper and announced through Bursa Securities; and
- (b) all other notices shall either be announced through the Bursa Securities or published in at least one (1) English language national daily newspaper.

- 12.2 A notice is deemed to have been given and served to the Holders on the date of announcement or publication as the case may be or, if announced or published more than once or on different dates, on the first date on which it is announced or published.

- 12.3 All notices effected in accordance with this Condition 12 shall be deemed to be effective in respect of all persons who become Holders after the date of the relevant notice.

- 12.4 For the avoidance of doubt, a notice shall not be required to be published or announced in respect of an event contemplated under Conditions 6 or 8, as the case may be, if no adjustment to the rights of the Holders or amendment to the terms and conditions of the relevant Structured Warrants is made or to be made pursuant thereto.

13 Modification of rights

- 13.1 All or any of the rights for the time being attached to the Structured Warrants (other than the Exercise Level which a Holder is entitled to or the formulae for the adjustment of the Exercise Level or the Exercise Ratio or any other condition, which may be modified in accordance with the provisions set out elsewhere in these Conditions) may be altered or abrogated by the Issuer from time to time (whether or not the Issuer is being wound up), and the sanction of a Special Resolution passed at a meeting of the Holders held as aforesaid shall be necessary to effect such alteration or abrogation.

- 13.2 Notwithstanding Condition 13.1, the Issuer may without the consent of the Holders but in accordance with the terms of the Deed Poll, effect any modification to the Structured Warrants or the Deed Poll which, in the opinion of the Issuer, is:

- (a) not materially prejudicial to the interests of the Holders; or
- (b) of a formal, minor or technical nature; or
- (c) necessary or expedient to correct a manifest error, or to comply with mandatory provisions of law; or
- (d) necessary or expedient to facilitate scripless trading in or exercise of the Structured Warrants or payment by way of electronic funds transfer as approved by the relevant government or statutory authorities in respect of the Structured Warrants or to amend the restrictions on transfer or exercise of the Structured Warrants to comply with the requirements of or the concessions granted by any relevant government or statutory authorities.

Any such modification shall be binding on all Holders and shall be notified by the Issuer to them as soon as practicable thereafter in accordance with Condition 12 but in any event not later than twenty (20) Market Days from the date of such modification.

- 13.3 Notwithstanding Condition 13.1, the Issuer may, at any time and from time to time for the purpose of an issue of new Structured Warrants or a new Series of Structured Warrants through the Base Prospectus and without the consent or sanction of the Holders supplement the Deed Poll with the terms and conditions of the new Structured Warrants or Series of Structured Warrants (as set out in the relevant Term Sheet), as the case may be. In the event such supplement to the Deed Poll shall affect the rights and interests of the Holders, the Issuer is to effect such supplement to the

ANNEXURE I PRINCIPAL TERMS OF THE DEED POLL (cont'd)

Deed Poll by notice to the Holders in accordance with Condition 12 and such supplement shall be binding on all Holders without any further action being required to be taken by the Issuer. For the avoidance of doubt, a Holder is deemed to have notice of all announcements (and their respective contents) made by the Issuer to Bursa Securities in respect of or affecting the Series of Structured Warrants held.

14 Warrant Agency Agreement

- 14.1 The Structured Warrants Registrar shall be acting as an agent of the Issuer and shall not assume any obligation or duty to or any relationship of agency or trust for the Holders except only as described in Condition 14.2 below.
- 14.2 The Warrant Agency Agreement contains provisions for the indemnification of the Structured Warrants Registrar. The Structured Warrants Registrar shall not be liable to any Holder in respect of any losses, liabilities, costs, claims, actions or demands which such Holder may suffer or incur or allege to have suffered or incurred as a result of or in connection with the exercise or non-exercise of any Structured Warrants Registrar's powers, discretions and/or duties. The Structured Warrants Registrar may:
- (a) in the exercise of its powers, discretions and/or duties, act on the advice or opinion of, or any certificate or information obtained in good faith from, any lawyer, valuer, accountant, banker, broker, securities company or other expert whether obtained by the Issuer, the relevant Structured Warrants Registrar or otherwise (which advice, opinion, certificate or information may be sent or obtained by letter, email, telex, telegram, cable or facsimile device) and the Structured Warrants Registrar shall not be liable for any loss occasioned by acting in good faith on any such advice, opinion, certificate or information unless there are reasonable grounds for concluding that the same may be forged or otherwise not authentic or containing some errors with respect to content, delivery or transmission;
 - (b) receive and retain without liability to account, such fee or other remuneration as may from time to time be agreed between the Issuer and the Structured Warrants Registrar; and
 - (c) enter into or be interested in any contract or financial or other transaction or arrangement with the Issuer or any person or body corporate associated with the Issuer in connection therewith to receive and retain, without liability to account any profit, fee, remuneration or other benefit received thereby or in connection therewith.

The Structured Warrants Registrar does not act as the agent of any Holder and therefore owes no fiduciary duty to any Holder in arriving at its calculations and determinations.

15 Exclusion of equities

- 15.1 Subject to the Central Depositories Act, the Rules of Bursa Depository, the Deed Poll, or these Conditions, no person shall be recognised by the Issuer as holding any Structured Warrants upon any trust, and the Issuer shall not be bound by or compelled in any way to recognise any equitable, contingent, future or partial interest in any Structured Warrant, or any interest in any fractional part of a Structured Warrant, or (except only as by these presents or by law otherwise provided) any other right in respect of any Structured Warrants, except an absolute right to the entirety thereof in the registered holder.

16 Force Majeure

- 16.1 If the Issuer determines that, for reasons beyond the Issuer's control, the performance of the Issuer's obligations under the Structured Warrants has become illegal or impractical in whole or in part for any reason, or the Issuer determines that, for reasons beyond the Issuer's control, it is no longer legal or practical for the Issuer to maintain the Issuer's hedging arrangements with respect to the Structured Warrants for any reason, the Issuer may in the Issuer's discretion and without obligation terminate the Structured Warrants early by giving notice to the Holders in accordance with Condition 12.

ANNEXURE I PRINCIPAL TERMS OF THE DEED POLL *(cont'd)*

17 Governing law

- 17.1 The Structured Warrants and the Deed Poll are governed by and shall be construed in accordance with the laws of Malaysia. The Issuer and the Holders irrevocably agree that with respect to any proceedings in Malaysia in connection with any matter or issue relating to the Deed Poll and these Conditions, they shall be bound by the decision, ruling or order of the Malaysian Court.

(the remainder of this page is intentionally left blank)

PART 5

CONDITIONS OF THE CASH-SETTLED SINGLE EXCHANGE-TRADED FUND CALL OR PUT WARRANTS

1 General, Nature, Form, Transfer, Administration and Status of Structured Warrants

- 1.1 The Structured Warrants comprise **American or European style non-collateralised cash-settled call or put warrants over a single exchange-traded fund** to be issued from time to time by the Issuer through the Base Prospectus and subject to, and with the benefit of the Deed Poll referred to on the face of the Structured Warrant Certificate and these Conditions. The Exercise Rights entitle the Holder of each Structured Warrant for each Series of Structured Warrants issued or to be issued, subject to the Deed Poll and in accordance with these Conditions, upon valid exercise thereof, to the Cash Settlement Amount calculated in accordance with Condition 2. Certain statements in these Conditions are summaries of and are subject to the detailed provisions of the Deed Poll and in the event of any inconsistency between a provision contained in these Conditions and a provision contained in the Deed Poll, the provisions in the Deed Poll shall prevail. The Issuer has entered into a Warrant Agency Agreement with the Structured Warrants Registrar. Copies of the Deed Poll and the Warrant Agency Agreement are available for inspection at the registered office of the Issuer, being at the date hereof at 22nd Floor, Bangunan AmBank Group, No. 55 Jalan Raja Chulan, 50200 Kuala Lumpur, Malaysia. The Holders for the time being of the Structured Warrants and whose names appear on the Record of Depositors are all entitled to the benefit of, bound by, and deemed to have notice of, all the provisions of the Deed Poll and the Warrant Agency Agreement. Further, each Holder acknowledges it has, where necessary, consulted its stockbroker, solicitor or other adviser before investing in the Structured Warrants and none of the Issuer or its directors or employees may be construed as investment adviser or agent of, or owe any fiduciary duty to the Holder. **For the purposes of this Part 5, the term “Structured Warrants” shall refer to the American or European style non-collateralised cash-settled call or put warrants over a single exchange-traded fund.**
- 1.2 Subject to the Central Depositories Act, the Rules of Bursa Depository, the Deed Poll, the relevant applicable rules and regulations and these Conditions:
- (a) each Structured Warrant is an option which confers on the Holder the Exercise Rights which require the Issuer to pay the Cash Settlement Amount to the Holder in accordance with these Conditions; and
 - (b) the Structured Warrants are issued in registered form, serially numbered and are a Prescribed Security to be admitted to the Official List. The Structured Warrants are represented by a global/jumbo certificate issued to Bursa Depository or its nominee who holds the same as bare trustee on behalf of the Holders, and deposited with Bursa Depository in or substantially in the form set out in the First Schedule to the Deed Poll as the same may from time to time be modified in accordance with the Deed Poll.
- 1.3 Subject to all information provided by the subscriber for the Structured Warrants to the Issuer being complete and consistent with the records of Bursa Depository, the Issuer shall within seven (7) Market Days from the date of allotment of the Structured Warrants, cause and procure the Structured Warrants Registrar to notify Bursa Depository of the names of the Holders together with such particulars as may be required by Bursa Depository for the purpose of making appropriate entries in the Securities Account of the respective Holder, request Bursa Depository to credit the Securities Account of the Holders with the applicable Structured Warrants and shall deliver to Bursa Depository the Structured Warrant Certificate registered in the name of Bursa Depository or its nominee company in such manner as may be prescribed by the Rules of Bursa Depository or agreed with Bursa Depository. If, at any time, the information provided by the Holders for the Structured Warrants is incorrect or inaccurate or inconsistent with the records of Bursa Depository, the Issuer reserves the right and without any obligation whatsoever to the Holders, to accept, reject or otherwise deal with the Structured Warrants in such manner as it reasonably deems fit in the circumstances. The Holders are not entitled to any physical warrant certificates.
- 1.4 Subject to the provisions of the Central Depositories Act and the Rules of Bursa Depository, the registration and subsequent administration of Structured Warrants shall be in the manner set forth in the Deed Poll and the Warrant Agency Agreement. It is hereby acknowledged that the Issuer

ANNEXURE I **PRINCIPAL TERMS OF THE DEED POLL** (cont'd)

shall be entitled to appoint registrars for the registration and administration of the Structured Warrants. The Issuer hereby confirms that it shall/has appointed the Structured Warrants Registrar for the purpose stipulated hereof, who shall perform such duties as required by the Issuer under the Deed Poll.

- 1.5 The Holders may transfer the Structured Warrants in the manner prescribed under the Central Depositories Act and the Rules of Bursa Depository. Subject to the provisions of the Central Depositories Act and the Rules of Bursa Depository, the Structured Warrants shall be freely transferable but the trading of the Structured Warrants must be in the same board lot applicable to the trading of the Underlying ETF or in such odd lots as permitted by the SC and/or Bursa Securities. Where the board lot of the Underlying ETF is more than one hundred (100) units per board lot, the Structured Warrants may be issued in board lots of one hundred (100) warrants.
- 1.6 The Structured Warrants and the settlement obligation of the Issuer in respect of the Structured Warrants represent general and unsecured contractual obligations of the Issuer and of no other person which rank, and shall rank, equally among themselves and without preference in all respects, subject to such exceptions as may from time to time exist under applicable law or the Deed Poll, with the other existing and future unsecured and unsubordinated obligations of the Issuer.
- 1.7 The Structured Warrants do not confer on the Holders any right to acquire or dispose of units of the Underlying ETF and the Issuer is not under any obligation whatsoever to purchase, hold or deliver such units, or any rights and benefits attaching thereto.
- 1.8 The Holders are entitled to the Cash Settlement Amount in accordance with Condition 2.

2 Exercise of the Structured Warrants**2.1 American style Structured Warrants**

- 2.1.1 The Structured Warrants may be exercised in the manner set out in Condition 2.1.2 at anytime from the date of issue up to the Expiry Date. In the event the date whereby the Exercise Form is delivered is not a Market Day, then it shall be deemed to be exercised on the next following Market Day.
- 2.1.2 In order to invoke the Exercise Rights, within the Exercise Period a Holder must complete and sign the Exercise Form (which shall be made available by the Structured Warrants Registrar in any manner as may be stipulated by Bursa Securities or such other relevant authority) and deliver the same on a Market Day between 9.00 a.m. to 5.00 p.m. to the Structured Warrants Registrar who shall acknowledge receipt by stamping the date and time of receipt on the Exercise Form in respect of which the Structured Warrants are being exercised.

Provided always that:

- (a) in every case compliance must also be made with the requirements set out in the Exercise Form and other prevailing statutory requirements for the time being applicable;
 - (b) the Holder shall, if so required by the Structured Warrants Registrar, furnish such evidence, if any, as the Structured Warrants Registrar or the directors of the Issuer may require to determine the due execution of the Exercise Form by or on behalf of the Holder exercising the same. Once a valid Exercise Form is duly delivered by the Holder to the Structured Warrants Registrar, the exercise of such Exercise Rights shall be irrevocable save with the consent of the directors of the Issuer; and
 - (c) where the Holder does not comply with the procedures or restrictions or conditions relating to the exercise of the Structured Warrants, the Exercise Form and any documents received shall be returned to such Holder by ordinary post to the Holder's address recorded in the Record of Depositors at the risk of the Holder.
- 2.1.3 Subject to notification by the Structured Warrants Registrar of fulfilment of the preconditions by the Holder to validly exercise the Structured Warrants as set out in Condition 2.1.2 within three (3) Market Days from the Exercise Date and the absence of a Settlement Disruption Event, the Issuer shall, within seven (7) Market Days from the Exercise Date or such other

ANNEXURE I PRINCIPAL TERMS OF THE DEED POLL (cont'd)

period as may be prescribed by Bursa Securities or such other relevant authority, pay to the relevant Holder the Cash Settlement Amount calculated as set out below less Exercise Expenses, if any:

For call warrants:

$$\text{Cash Settlement Amount} = \text{Number of Structured Warrants} \times \frac{(\text{Closing Price}^{(1)} - \text{Exercise Price}^{(2)})}{1} \times \text{Exercise Ratio}^{(2)} \times \text{Settlement Exchange Rate (if applicable)}$$

For put warrants:

$$\text{Cash Settlement Amount} = \text{Number of Structured Warrants} \times \frac{(\text{Exercise Price}^{(2)} - \text{Closing Price}^{(1)})}{1} \times \text{Exercise Ratio}^{(2)} \times \text{Settlement Exchange Rate (if applicable)}$$

- (1) The Closing Price shall be calculated by reference to either:
- (a) In the event a valid Exercise Form is received in accordance with Condition 2.1.2 by the Structured Warrants Registrar:
 - (i) before 12.30 p.m. on any Market Day other than on the Expiry Date, the exercise of the Structured Warrants shall be deemed to have been made on that Market Day and in such instance the Market Day of receipt of the Exercise Form shall be the Exercise Date and the Valuation Date and the Closing Price shall be the closing price of the Underlying ETF on such Valuation Date; or
 - (ii) on or after 12.30 p.m. on any Market Day other than on the Expiry Date, the exercise of the Structured Warrants shall be deemed to have been made on the Market Day immediately following the Market Day of receipt of the Exercise Form and in such instance the Market Day immediately following the Market Day of receipt of the Exercise Form shall be the Exercise Date and the Valuation Date and the Closing Price shall be the closing price of the Underlying ETF on such Valuation Date. For the avoidance of doubt, if a valid Exercise Form is received on or after 12.30 p.m. on a Market Day immediately preceding the Expiry Date, the exercise of the Structured Warrants shall be deemed to have been made on the Expiry Date and in such instance the Closing Price shall be the Expiry Date Closing Price (as defined below) of the Underlying ETF; or
 - (iii) on the Expiry Date, the Closing Price shall be the Expiry Date Closing Price (as defined below) of the Underlying ETF,

and as specified in the relevant Term Sheet and subject to the Market Disruption Event provision below.

If the Underlying ETF is delisted, the Closing Price shall be determined in accordance with Condition 9.

If the Exercise Date falls on a Market Day when the Underlying ETF is suspended from trading for any reason, the Closing Price shall be the last quoted price of such Underlying ETF immediately before the suspension (subject to the Market Disruption Event provision below).

- (b) In the event of any exercise of the Structured Warrants on the Expiry Date, the Closing Price shall be calculated by reference to either:

ANNEXURE I**PRINCIPAL TERMS OF THE DEED POLL (cont'd)**

- (i) the average VWAP of the Underlying ETF (subject to any adjustment as may be necessary to reflect any capitalisation, rights issue, distribution or others) for the five (5) Market Days prior to and including the Market Day immediately before the Expiry Date; or
- (ii) the average closing price of the Underlying ETF (subject to any adjustment as may be necessary to reflect any capitalisation, rights issue, distribution or others) for the five (5) Market Days prior to and including the Market Day immediately before the Expiry Date; or
- (iii) the closing price of the Underlying ETF on the Market Day immediately before the Expiry Date,

and as specified in the relevant Term Sheet ("**Expiry Date Closing Price**") and subject to the Market Disruption Event and other provisions herein.

In the event the Underlying ETF is delisted, the Expiry Date Closing Price shall be determined in accordance with Condition 9.

- (c) If a Market Disruption Event, or a public holiday unexpected by the Issuer occurs on any of the five (5) Market Days described in sub-Conditions (1)(b)(i) or (1)(b)(ii) above, the valuation period applicable and the Closing Price shall be as determined by the Issuer in such manner as it reasonably deems fit.

In any other cases where there is a single Valuation Date, if there is a Market Disruption Event on the Valuation Date, the Valuation Date shall be the next following Market Day after the Market Disruption Event. If the Market Disruption Event continues to occur up to the eighth (8th) Business Day following the original Valuation Date, then the Valuation Date shall be:

- (i) that eighth (8th) Business Day; and
- (ii) the Issuer shall determine as it reasonably deems fit and on the basis of the Issuer's good faith estimate the reference price and/or the exchange rate (if applicable) for that Valuation Date by determining the price of the Underlying ETF and/or the exchange rate (if applicable) based on the prevailing market conditions and other factors as the Issuer may consider relevant.

- (2) The Exercise Price and/or Exercise Ratio shall be subject to the adjustments as may be necessary as provided in Condition 6.

2.1.4 In the event that the Cash Settlement Amount after deduction of the Exercise Expenses, if any, is equal to or less than zero, the Issuer shall not be obliged to make any payment to the relevant Holder, and the Structured Warrants exercised shall thereafter become void and cease to have the Exercise Rights and the Issuer's obligations in respect of the Structured Warrants shall terminate absolutely. For the avoidance of doubt, the Holder shall not be required to pay or top-up the Exercise Expenses, if any, as the case may be, where the Cash Settlement Amount after deduction of the Exercise Expenses, if any, is less than zero.

2.1.5 If the Structured Warrants are not earlier exercised, the Structured Warrants shall be deemed automatically exercised at 5.00 p.m. on the Expiry Date, without the Holders having to deliver a valid Exercise Form to the Structured Warrants Registrar and without notice of automatic exercise being given by the Issuer to the Holders.

ANNEXURE I PRINCIPAL TERMS OF THE DEED POLL (cont'd)

2.1.6 Upon automatic exercise of the Structured Warrants on the Expiry Date in accordance with Condition 2.1.5, if the Cash Settlement Amount after deduction of the Exercise Expenses, if any:

- (a) is greater than zero, in the absence of a Settlement Disruption Event, payment shall be made by the Issuer to the relevant Holders within seven (7) Market Days from the Expiry Date and the Issuer's obligations in respect of the Structured Warrants, shall terminate absolutely; or
- (b) is equal to or less than zero, the Structured Warrants shall terminate and cease to be valid and the Issuer's obligations in respect of the Structured Warrants, shall terminate absolutely. For the avoidance of doubt, the Holder shall not be required to pay or top-up the Exercise Expenses, if any, as the case may be, where the Cash Settlement Amount after deduction of the Exercise Expenses, if any, is less than zero.

2.2 European style Structured Warrants

2.2.1 The Structured Warrants shall be automatically exercised at 5.00 p.m. on the Expiry Date if the Cash Settlement Amount calculated in accordance with Condition 2.2.2 after deduction of the Exercise Expenses, if any, is greater than zero (without the Holders having to deliver a valid Exercise Form and without notice of automatic exercise being given by the Issuer to the Holders). If the Expiry Date is not a Market Day then it shall be deemed to be exercised on the next following Market Day. The Structured Warrants will automatically terminate and cease to be valid at 5.00 p.m. on the Expiry Date if the Cash Settlement Amount after deduction of the Exercise Expenses, if any, is equal to or less than zero and the Issuer's obligations in respect of the Structured Warrants shall terminate absolutely. For the avoidance of doubt, the Holder shall not be required to pay or top-up the Exercise Expenses, if any, as the case may be, where the Cash Settlement Amount after deduction of the Exercise Expenses, if any, is less than zero.

2.2.2 The Issuer shall in the absence of a Settlement Disruption Event, within seven (7) Market Days from the Expiry Date or such other period as may be prescribed by Bursa Securities or such other relevant authority, pay to the relevant Holder, the Cash Settlement Amount calculated as set out below less Exercise Expenses, if any:

For call warrants:

$$\text{Cash Settlement Amount} = \text{Number of Structured Warrants} \times \frac{(\text{Closing Price}^{(1)} - \text{Exercise Price}^{(2)})}{\text{Exercise Ratio}^{(2)}} \times \frac{1}{\text{Exercise Ratio}^{(2)}} \times \text{Settlement Exchange Rate (if applicable)}$$

For put warrants:

$$\text{Cash Settlement Amount} = \text{Number of Structured Warrants} \times \frac{(\text{Exercise Price}^{(2)} - \text{Closing Price}^{(1)})}{\text{Exercise Ratio}^{(2)}} \times \frac{1}{\text{Exercise Ratio}^{(2)}} \times \text{Settlement Exchange Rate (if applicable)}$$

(1) (a) The Closing Price on the Expiry Date shall be calculated by reference to either:

- (i) the average VWAP of the Underlying ETF (subject to any adjustment as may be necessary to reflect any capitalisation, rights issue, distribution or others) for the five (5) Market Days prior to and including the Market Day immediately before the Expiry Date; or
- (ii) the average closing price of the Underlying ETF (subject to any adjustment as may be necessary to reflect any capitalisation, rights

ANNEXURE I**PRINCIPAL TERMS OF THE DEED POLL** (cont'd)

issue, distribution or others) for the five (5) Market Days prior to and including the Market Day immediately before the Expiry Date; or

- (iii) the closing price of the Underlying ETF on the Market Day immediately before the Expiry Date,

and as specified in the relevant Term Sheet and subject to the Market Disruption Event and other provisions herein.

If the Underlying ETF is delisted, the Closing Price shall be determined in accordance with Condition 9 below.

- (b) If a Market Disruption Event, or a public holiday unexpected by the Issuer occurs on any of the five (5) Market Days described in sub-Conditions (1)(a)(i) or (1)(a)(ii) above, the valuation period applicable and the Closing Price shall be as determined by the Issuer in such manner as it reasonably deems fit.

In any other cases where there is a single Valuation Date, if there is a Market Disruption Event on the Valuation Date, the Valuation Date shall be the next following Market Day after the Market Disruption Event. If the Market Disruption Event continues to occur up to the eighth (8th) Business Day following the original Expiry Date, then the Expiry Date shall be:

- (i) that eighth (8th) Business Day; and
- (ii) the Issuer shall determine as it reasonably deems fit and on the basis of the Issuer's good faith estimate the reference price and/or the exchange rate (if applicable) for that Expiry Date by determining the price of the Underlying ETF and/or the exchange rate (if applicable) based on the prevailing market conditions and other factors as the Issuer may consider relevant.

- (2) The Exercise Price and/or Exercise Ratio shall be subject to such adjustments as may be necessary as provided in Condition 6.

2.2.3 In the event that the Cash Settlement Amount after deduction of the Exercise Expenses, if any, is equal to or less than zero on the Expiry Date, the Structured Warrants shall terminate on the Expiry Date and cease to be valid and the Issuer's obligations in respect of the Structured Warrants shall terminate absolutely. For the avoidance of doubt, the Holder shall not be required to pay or top-up the Exercise Expenses, if any, as the case may be, where the Cash Settlement Amount after deduction of the Exercise Expenses, if any, is less than zero.

2.3 (a) The Cash Settlement Amount less the Exercise Expenses, if any, shall be made by way of cheque drawn in favour of the Holder to be delivered by ordinary post to the Holder's address last recorded in the Record of Depositors at the Holder's own risk or by way of electronic transfer of funds to the bank account of the Holder, the details of which are provided by Bursa Depository to the Issuer at the request of the Issuer. Where the Issuer makes a payment to a Holder pursuant to the terms of Conditions 2.1 or 2.2, the amount of such payment arising from the exercise of the Structured Warrants shall be final and conclusive and the Issuer shall be discharged from its obligation upon making such payment thereof in accordance with these Conditions.

(b) The Cash Settlement Amount less the Exercise Expenses, if any, shall be calculated and be payable in the Settlement Currency and rounded down to the nearest two (2) decimal points. All determinations made by the Issuer pursuant to Conditions 2.1 or 2.2 shall be final and conclusive and binding on the Holders.

(c) The Holder is to bear all Exercise Expenses, if any, in relation to the exercise of the Structured Warrants and on exercise of the Structured Warrants, the Issuer shall be irrevocably authorised by the Holder to deduct all Exercise Expenses, if any, from the Cash Settlement Amount.

ANNEXURE I **PRINCIPAL TERMS OF THE DEED POLL** (cont'd)

- (d) If as a result of a Settlement Disruption Event, it is not possible for the Issuer to make payment on the original Settlement Date, the Issuer shall use its reasonable endeavours to procure payment as soon as practicable after the original Settlement Date. The Issuer shall not be liable to the Holder for any interest in respect of the amount due or any loss or damage that such Holder may suffer as a result of the existence of the Settlement Disruption Event.
- 2.4 The Issuer shall not allow the Holder to exercise the Exercise Rights unless the Structured Warrants are or have been designated as “free securities” in accordance with the Rules of Bursa Depository.
- 2.5 The Issuer declares that approval shall be sought from Bursa Securities for the admission of the Structured Warrants to the Official List and for the listing of and quotation for the Structured Warrants on Bursa Securities.
- 2.6 All questions as to the validity, form, eligibility (including time of receipt) and acceptance of Exercise Form shall be resolved by the Structured Warrants Registrar in a manner as it reasonably deems fit, whose determination shall be final and binding on the Issuer and the Holder. The Structured Warrants Registrar is entitled to reject any Exercise Form that is not in proper form or the acceptance of which may, in the view of counsel for the Structured Warrants Registrar be unlawful. The Structured Warrants Registrar also reserves the right, subject to applicable law, to waive any irregularities. The interpretation of the Structured Warrants Registrar of the terms and conditions of exercise of the Structured Warrants shall be final and binding on the Issuer and the Holder. Unless waived, any irregularities in connection with the Exercise Form must be rectified by such time, as the Structured Warrants Registrar shall determine. The Structured Warrants Registrar shall not be under any duty to give notification of any irregularities in such Exercise Form and shall not incur liabilities for failure to give such notification. The Exercise Form shall not be considered to have been validly delivered until such irregularities have been rectified and waived.
- 2.7 The initial Structured Warrants Registrar and its specified offices are stated in the Deed Poll. The Issuer reserves the right at any time to terminate the appointment of the Structured Warrants Registrar. Prior written notice of any termination, appointment of Structured Warrants Registrar, resignation of the Structured Warrants Registrar or any changes in any of the specified offices of the relevant Structured Warrants Registrar shall be given to the Holders in accordance with Condition 15 and such prior notice shall be given to the Holders not more than sixty (60) days and less than thirty (30) days of such termination, appointment, resignation or change.
- 2.8 In respect of each Structured Warrant in which Exercise Rights have been exercised, the Issuer shall instruct or procure the Structured Warrants Registrar to instruct Bursa Depository to debit the appropriate number of Structured Warrants in respect of which Exercise Rights have been exercised from the Securities Account of such Holder. The Issuer shall be entitled at any time on or after the Expiry Date, to demand that Bursa Depository deliver to the Issuer the Structured Warrant Certificates and thereafter cancel or cause the cancellation of the Structured Warrant Certificates.
- 2.9 The Structured Warrants subject to the Exercise Rights which have been exercised in accordance with the Deed Poll shall cease to exist and all obligations of the Issuer in respect of those Structured Warrants shall terminate absolutely following payment of the amount (if any) referred to in this Condition 2.
- 3 Exercise Rights and Suspension**
- 3.1 Upon and subject to the provisions of the Central Depositories Act, the Rules of Bursa Depository and the Deed Poll, the Holder whose name as stated in the Record of Depositors shall have the right at any time during the Exercise Period to invoke its Exercise Rights at the Exercise Price subject to adjustments in accordance with Condition 6.
- 3.2 The Structured Warrants shall, subject to any directions, order or notice from any relevant regulatory authority and any request for suspension by the Issuer which is not rejected by any such relevant regulatory authority, continue to be traded notwithstanding that the trading of the Underlying ETF may have been suspended. Any suspension in the trading of the Underlying ETF or the Structured Warrants shall not preclude the Holder from exercising the Exercise Rights.

ANNEXURE I PRINCIPAL TERMS OF THE DEED POLL (cont'd)

3.3 The Issuer shall notify the Holders of the Expiry Date at least one (1) month prior to the Expiry Date or such other period as may be specified by the relevant authority. Such notice shall be given in accordance with Condition 15 stating the Expiry Date and treatment of the Structured Warrants which are not exercised.

4 Deposit and Forfeiture of Unclaimed Amount

4.1 In the event that the Issuer pays the Cash Settlement Amount to any Holder under Condition 2 and such Holder does not present the cheque for payment within six (6) months from the date of the cheque, the Issuer shall at any time thereafter deal with the said monies in accordance and in compliance with, the requirements of the Unclaimed Moneys Act 1965 (Act 370) (revised 1989) of Malaysia.

5 Designation of Structured Warrants set out in the Exercise Form

5.1 Subject to the approval of Bursa Depository and/or other relevant authority, the Issuer reserves all rights to instruct Bursa Depository and/or other relevant authority to designate the Structured Warrants held in the relevant Securities Account of a Holder which the Holder has purportedly exercised by submitting an Exercise Form to the Issuer and/or the Structured Warrants Registrar, in order for Bursa Depository and/or the relevant authority to prohibit the Holder from trading on the exchange the designated Structured Warrants after the aforesaid exercise. The Issuer's right to instruct Bursa Depository and/or the relevant authority shall be independent of whether the exercise is valid or otherwise, provided that the amount of Structured Warrants so designated by Bursa Depository and/or the relevant authority do not exceed the amount set out in such Exercise Form.

6 Adjustment of Exercise Price and/or Exercise Ratio

6.1 Adjustments

Subject to the Conditions as hereinafter provided and the Deed Poll, the Exercise Price and/or the Exercise Ratio shall from time to time be adjusted in accordance with the following provisions:

(a) Bonus Issue

If and whenever there is an issue of new units credited as fully paid-up to the holders of units generally (other than pursuant to a scrip distribution or similar scheme for the time being or otherwise in lieu of a cash distribution and without any payment or other consideration being made or given by such holders) ("**Bonus Issue**"), the Exercise Price and/or Exercise Ratio shall be adjusted on the Market Day immediately following the last day on which an instrument of transfer could be lodged so that the transferee of the units would qualify for the Bonus Issue in accordance with the following formula:

$$(i) \quad \text{Adjusted Exercise Ratio} = \frac{E}{(1 + N)}$$

$$(ii) \quad \text{Adjusted Exercise Price} = \frac{X}{(1 + N)}$$

Whereby in respect of this Condition 6.1(a)(i) and (ii):

X = Existing Exercise Price immediately prior to the Bonus Issue.

N = The number of additional units (whether a whole or a fraction) received by a holder of existing units for each unit held prior to the Bonus Issue.

E = Existing Exercise Ratio immediately prior to the Bonus Issue.

Alternatively, the Issuer may also, in good faith, make a corresponding adjustment to the Exercise Ratio and/or Exercise Price as the Issuer determines appropriate to account for the dilutive effect of the Bonus Issue.

ANNEXURE I **PRINCIPAL TERMS OF THE DEED POLL** (cont'd)

On any such adjustment, the resultant Exercise Ratio and/or Exercise Price shall be rounded to the nearest four (4) decimal points of the Relevant Currency and all such adjustment made by the Issuer pursuant to this Condition shall be deemed as final and conclusive save for any manifest error.

(c) **Distribution Payment**

Should the Underlying ETF of the relevant Structured Warrants undertake a special distribution payment in cash during the tenure of the Structured Warrants, the Exercise Price and/or the Exercise Ratio of the Structured Warrants may be adjusted (as the Issuer reasonably deems fit) on the Market Day following the last day on which an instrument of transfer is lodged to enable the transferee of the Underlying ETF to qualify for the special distribution payment by the amount of the special distribution payment, net of taxation, if any.

The Exercise Ratio and/or Exercise Price for the Structured Warrants shall be adjusted in accordance with the following formula:

(i) Adjusted Exercise Ratio =

$$E \times \frac{(P - D)}{P}$$

(ii) Adjusted Exercise Price =

$$X \times \frac{(P - D)}{P}$$

Whereby, in respect of this Condition 6.1(b)(i) and (ii):

P = Closing Price of the Underlying ETF on the last market day on which the Underlying Equity is traded on a cum-entitlement basis.

D = The special distribution amount per one (1) Underlying ETF unit held.

X = Existing Exercise Price immediately prior to the dividend payment.

E = Existing Exercise Ratio immediately prior to the dividend payment.

The Exercise Ratio and/or Exercise Price of the Structured Warrants shall not be adjusted for distribution payment in specie or in the form of other securities, other than for bonus issue pursuant to Condition 6.1(a).

Alternatively, the Issuer may also, in good faith, make a corresponding adjustment to the Exercise Ratio and/or Exercise Price as the Issuer determines appropriate to account for the effect of the dividend payment.

On any such adjustment, the resultant Exercise Ratio and/or Exercise Price shall be rounded to the nearest four (4) decimal points of the Relevant Currency and all such adjustment made by the Issuer pursuant to this Condition shall be deemed as final and conclusive save for any manifest error.

(c) **Subdivision or Consolidation**

If and whenever there is a subdivision of units or any class of outstanding units into a greater number of units (a "**Subdivision**"), or consolidation of the units or any class of its outstanding units into a smaller number of units (a "**Consolidation**"), the Exercise Price and/or the Exercise Ratio shall be adjusted on the Market Day on which the relevant Subdivision or Consolidation shall have taken effect in accordance with the following formula:

ANNEXURE I **PRINCIPAL TERMS OF THE DEED POLL** (cont'd)

(i) Adjusted Exercise Ratio =

$$\frac{E \times N}{P}$$

Adjusted Exercise Price =

$$\frac{X \times N}{P}$$

Whereby, in respect of this Condition 6.1(c)(i) and (ii):

- X = Existing Exercise Price immediately prior to the Subdivision or Consolidation.
- N = Revised par value after the Subdivision or Consolidation.
- P = Existing par value immediately prior to the Subdivision or Consolidation.
- E = Existing Exercise Ratio immediately prior to the Subdivision or Consolidation.

Alternatively, the Issuer may also, in good faith, make a corresponding adjustment to the Exercise Ratio and/or Exercise Price as the Issuer determines appropriate to account for the dilutive or consolidative effect of the Subdivision or Consolidation.

On any such adjustment, the resultant Exercise Price and/or Exercise Ratio shall be rounded to the nearest four (4) decimal points of the Relevant Currency and all such adjustment made by the Issuer pursuant to this Condition shall be deemed as final and conclusive save for any manifest error.

(d) Other adjustments

The Issuer is entitled to make other adjustments as it reasonably believes are appropriate in circumstances where an event or events occur which the Issuer believes (notwithstanding any adjustment previously made by the Issuer) should, in the context of the issue of Structured Warrants and its obligations hereunder, give rise to such adjustment. The Issuer shall make such adjustment generally without considering the individual circumstances of any Holder or the tax or other consequences of such adjustment in any particular jurisdiction.

On any such adjustment, the resultant Exercise Price and/or Exercise Ratio shall be rounded to the nearest four (4) decimal points of the Relevant Currency.

6.2 Notwithstanding the foregoing, no adjustments shall be made to the Exercise Price and/or Exercise Ratio if the formulae stated in Condition 6.1(a) to Condition 6.1(d) results in an adjustment which would amount to less than two percent (2%) of the Exercise Price and/or Exercise Ratio being changed.

6.3 Any adjustment made pursuant to Conditions 6.1 and 6.2 shall be final and binding on the Holders save in the case of manifest error. Notice of such adjustments or amendments shall be given to the Holders as soon as practicable thereafter in accordance with Condition 15 and in any event within five (5) Market Days of the adjustment being made.

7 Restrictions to Protect Rights of Holders

7.1 As from the date of the issue of the Structured Warrants and for so long as any of the Structured Warrants remain exercisable, the Issuer shall have arrangements in place to ensure, for the benefit of the Holders that it is able to satisfy in full the exercise of all the Structured Warrants for the time being outstanding.

8 Merger or Consolidation of Underlying ETF

8.1 If it is announced that the Underlying ETF is to or may merge with or consolidate into any other fund, other collective investment scheme or otherwise or that all or substantially all of its assets are

ANNEXURE I **PRINCIPAL TERMS OF THE DEED POLL** (cont'd)

or may be sold or transferred, ("**Restructuring Event**") the Issuer may in good faith take any of the actions below:

- (a) cancel the Structured Warrants without prior notice to the Holders. If the Structured Warrants are so cancelled, the Issuer shall pay an amount to each Holder if the Cash Settlement Amount after deduction of the Exercise Expenses, if any, is greater than zero (without the Holder having to deliver a valid Exercise Form). The Cash Settlement Amount shall be determined by the Issuer in a manner as it reasonably deems fit based on the fair market value of the Underlying ETF (as determined by the Issuer) after taking into account the Restructuring Event less all Exercise Expenses, if any; and/or
 - (b) amend and determine the appropriate adjustment, if any, to be made to the terms and conditions of the Structured Warrants to account for the Restructuring Event and determine the effective date of that adjustment. After such adjustments (if any), the Structured Warrants shall relate to the number of units resulting from or surviving such Restructuring Event or other securities ("**Substituted Securities**") and/or cash offered in substitution for the affected Underlying ETF of the relevant Structured Warrants to which the holder of such number of Underlying ETF to which the Structured Warrants related immediately before such Restructuring Event would have been entitled upon such Restructuring Event, as the case may be. The Issuer may, but need not, determine the appropriate adjustment by reference to the adjustment in respect of the Restructuring Event made by a Securities Exchange to options on the relevant Underlying ETF traded on that Securities Exchange.
- 8.2 Upon the occurrence of a Restructuring Event, the rights attaching to the Structured Warrants in respect of that Underlying ETF may be amended by the Issuer no later than the Market Day preceding the consummation of such Restructuring Event.
- 8.3 The provisions of these Conditions shall apply to such Substituted Securities provided that, any Substituted Securities may, as the Issuer reasonably deems fit, be replaced by an amount in the Relevant Currency equal to the market value or, if no market value is available, fair value, of such Substituted Securities in each case as determined by the Issuer as soon as practicable after such Restructuring Event is effected.
- 8.4 Any cancellation of Structured Warrants or modification of rights made pursuant to Condition 8.1 or 8.2 shall be notified to the Holders as soon as practicable thereafter and in any event within five (5) Market Days from the date of such cancellation or modification in accordance with Condition 15.

9 Delisting of the Underlying ETF

- 9.1 If at any time the Underlying ETF of the Structured Warrants ceases to be listed on Bursa Securities or such other Securities Exchanges or there is an announcement of an intention to cease the listing of the Underlying ETF or the Underlying ETF is suspended from trading on Bursa Securities or such other Securities Exchanges prior to, and in connection with the delisting of the Underlying ETF, the Structured Warrants may if determined by the Issuer be automatically exercised without the Holder having to deliver a valid Exercise Form and without notice of automatic exercise being given by the Issuer to the Holder:
- (a) if the Cash Settlement Amount after deduction of the Exercise Expenses, if any, is greater than zero, the Issuer shall make payment of the Cash Settlement Amount to the relevant Holder; or
 - (b) if the Cash Settlement Amount after deduction of the Exercise Expenses, if any, is equal to or less than zero, the Issuer shall not be obliged to make any payment to the relevant Holder and the relevant Structured Warrants shall terminate and cease to be valid and the Issuer's obligations in respect of the Structured Warrants shall terminate absolutely. For the avoidance of doubt, the Holder shall not be required to pay or top-up the Exercise Expenses, if any, as the case may be, where the Cash Settlement Amount after deduction of the Exercise Expenses, if any, is less than zero.

The Closing Price for the calculation of the Cash Settlement Amount (calculated in accordance with Condition 2) shall be the last quoted price of the Underlying ETF immediately before such events or determined in accordance with Condition 2.1.3(1)(b) or 2.2.2, as the case may be, and the Issuer shall not be obliged to make any adjustment to the Exercise Price.

ANNEXURE I PRINCIPAL TERMS OF THE DEED POLL (cont'd)

Provided that if there is a Market Disruption Event on the date immediately before such events (“**Set Date**”), the Closing Price shall be based on the Market Day immediately preceding the Market Disruption Event. If the preceding Market Day is also affected by the Market Disruption Event, then the Closing Price shall be determined by the Issuer on the Set Date as it reasonably deems fit and on the basis of the Issuer’s good faith estimate the reference price and/or the exchange rate (if applicable) for that Set Date by determining the price of the Underlying ETF and/or the exchange rate (if applicable) based on the prevailing market conditions and other factors as the Issuer may consider relevant.

- 9.2 Subject to the aforesaid, the Issuer may but shall not be obliged to make any adjustment to the terms and conditions of the Structured Warrants and the rights attaching to the Structured Warrants as it shall reasonably consider appropriate to ensure that the interests of the Holders generally are not materially prejudiced as a consequence of such events (without considering the individual circumstances of any Holder or the tax or other consequences that may result in any particular jurisdiction).

10 Liquidation, Dissolution or Winding-Up of the Underlying ETF

- 10.1 In the event of a liquidation, dissolution or winding-up of the Underlying ETF or the appointment of a liquidator, receiver or administrator or analogous person under any applicable law in respect of the whole or substantially the whole of the Underlying ETF’s Assets, the Structured Warrants will be automatically exercised without the Holder having to deliver a valid Exercise Form and without notice of automatic exercise being given by the Issuer to the Holder:

- (a) if the Cash Settlement Amount after deduction of the Exercise Expenses, if any, is greater than zero, the Issuer shall make payment of the Cash Settlement Amount to the relevant Holder; or
- (b) if the Cash Settlement Amount after deduction of the Exercise Expenses, if any, is equal to or less than zero, the Issuer shall not be obliged to make any payment to the relevant Holder and the relevant Structured Warrants shall terminate and cease to be valid and the Issuer’s obligations in respect of the Structured Warrants shall terminate absolutely. For the avoidance of doubt, the Holder shall not be required to pay or top-up the Exercise Expenses, if any, as the case may be, where the Cash Settlement Amount after deduction of the Exercise Expenses, if any, is less than zero.

The Closing Price for the calculation of the Cash Settlement Amount (calculated in accordance with Condition 2) shall be the closing price of the Underlying ETF on the Market Day immediately before such events or determined in accordance with Condition 2.1.3(1)(b) or 2.2.2, as the case may be, and the Issuer shall not be obliged to make any adjustment to the Exercise Price.

Provided that if there is a Market Disruption Event on the date immediately before such events (“**Set Date**”), the Closing Price shall be based on the Market Day immediately preceding the Market Disruption Event. If the preceding Market Day is also affected by the Market Disruption Event, then the Closing Price shall be determined by the Issuer on the Set Date as it reasonably deems fit and on the basis of the Issuer’s good faith estimate the reference price and/or the exchange rate (if applicable) for that Set Date by determining the price of the Underlying ETF and/or the exchange rate (if applicable) based on the prevailing market conditions and other factors as the Issuer may consider relevant.

- 10.2 Subject to the aforesaid, the Issuer may but shall not be obliged to make any adjustment to the terms and conditions of the Structured Warrants and the rights attaching to the Structured Warrants as it shall reasonably consider appropriate to ensure that the interests of the Holders generally are not materially prejudiced as a consequence of such events (without considering the individual circumstances of any Holder or the tax or other consequences that may result in any particular jurisdiction).

11 Takeover, Merger, Liquidation, Dissolution or Winding-Up of Issuer

- 11.1 In the event of a take-over or a scheme of arrangement or any other form of reorganisation undertaken by the Issuer or any other events having similar effects on the rights of the Holders, the Issuer is entitled to deal with the Structured Warrants in such manner as it reasonably deems fit in

ANNEXURE I PRINCIPAL TERMS OF THE DEED POLL (cont'd)

the circumstances and with or without any adjustments to the rights attaching to the relevant Structured Warrants.

- 11.2 In the event of a merger, amalgamation or reconstruction of the Issuer, the corporation, trust or other body into which the Issuer is merged, amalgamated or reconstructed shall assume all the liabilities and the obligations of the Issuer in respect of the Structured Warrants so that the rights of the Holders shall continue to exist and be enforceable to the same extent as provided by the Issuer under the Deed Poll.
- 11.3 In the event of a liquidation, dissolution or winding-up of the Issuer or the appointment of a receiver or administrator or analogous person under any applicable law in respect of the whole or substantially the whole of the Issuer's Assets, the Structured Warrants remaining outstanding shall be deemed to be exercised on the Market Day immediately prior to the date of such liquidation, dissolution, winding-up or appointment as follows:
- (a) All unexercised Structured Warrants shall be automatically exercised without the Holders having to deliver a valid Exercise Form and without notice of automatic exercise being given by the Issuer to the Holders:
- (i) if the Cash Settlement Amount after deduction of the Exercise Expenses, if any, is greater than zero, the Issuer shall make payment of the Cash Settlement Amount to the relevant Holder; or
- (ii) if the Cash Settlement Amount after deduction of the Exercise Expenses, if any, is equal to or less than zero, the Issuer shall not be obliged to make any payment to the relevant Holder and the relevant Structured Warrants shall terminate and cease to be valid and the Issuer's obligations in respect of the Structured Warrants shall terminate absolutely. For the avoidance of doubt, the Holder shall not be required to pay or top-up the Exercise Expenses, if any, as the case may be, where the Cash Settlement Amount after deduction of the Exercise Expenses, if any, is less than zero.

The closing price of the Underlying ETF on the Market Day immediately before the above events shall form the Closing Price for the calculation of the Cash Settlement Amount.

- (b) Notwithstanding the foregoing, if there is a Market Disruption Event on the Set Date, the Closing Price shall be based on the Market Day immediately preceding the Market Disruption Event. If the preceding Market Day is also affected by the Market Disruption Event, the Closing Price shall be determined by the Issuer on the Set Date as it reasonably deems fit and on the basis of the Issuer's good faith estimate the reference price and/or the exchange rate (if applicable) for that Set Date by determining the price of the Underlying ETF and/or the exchange rate (if applicable) based on the prevailing market conditions and other factors as the Issuer may consider relevant.

12 Replacement of Structured Warrant Certificate

- 12.1 If the Structured Warrant Certificate which has been deposited with Bursa Depository is mutilated, defaced, lost, worn out, stolen or destroyed it shall be replaced by the Issuer at the registered office of the Structured Warrants Registrar on such terms as to evidence and indemnity or otherwise as the Issuer may require. All payment of such costs as may be incurred in connection therewith shall be borne by the Issuer. Mutilated, defaced, lost, worn, stolen or destroyed Structured Warrant Certificates shall be deemed cancelled.

13 Register, Transfer and Transmission

- 13.1 Each Holder registered in the Record of Depositors shall be entitled to all rights, benefits, powers and privileges and be subject to all liabilities, duties and obligations in respect of, or arising from the Structured Warrants, and shall be deemed and treated as the absolute owner of the relevant Structured Warrants, in accordance with the Central Depositories Act and the Rules of Bursa Depository, whether or not the Issuer shall be in default in respect of the Structured Warrants or any of the covenants contained herein and notwithstanding any notice of ownership or writing thereon or notice of any previous loss or theft of any Structured Warrants. The provisions of the Central Depositories Act, the Rules of Bursa Depository and the Issuer's constitution for the time

ANNEXURE I **PRINCIPAL TERMS OF THE DEED POLL** (cont'd)

being relating to the registration, transfer and transmission of shares and the fees payable thereon shall with necessary modifications apply to the registration, transfer and transmission of the legal ownership of the Structured Warrants, subject always to the provisions of this Condition 13 and Condition 2.

- 13.2 The entries made under the Record of Depositors shall be deemed to be the final record of all Depositors. No notice of any trust, express or implied, shall be entered upon the Record of Depositors otherwise than pursuant to an order of a court of competent jurisdiction or as required by law, and a Holder shall be deemed to be the beneficial owner of the Structured Warrants standing to the credit of his/its Securities Account, until such time as the Structured Warrants are duly transferred to another Holder and the name of the transferee is entered in the Record of Depositors.

14 Meetings of Holders

- 14.1 The procedure governing the convening and conduct of meetings of the Holders are set out in the Fourth Schedule to the Deed Poll.

15 Notices

- 15.1 Subject to Condition 15.2:

- (a) all notices to the Holders pertaining to the convening of meetings shall be made by way of notice published in at least one (1) English language national daily newspaper and announced through Bursa Securities; and
- (b) all other notices shall either be announced through the Bursa Securities or published in at least one (1) English language national daily newspaper.

- 15.2 A notice is deemed to have been given and served to the Holders on the date of announcement or publication as the case may be or, if announced or published more than once or on different dates, on the first date on which it is announced or published.

- 15.3 All notices effected in accordance with this Condition 15 shall be deemed to be effective in respect of all persons who become Holders after the date of the relevant notice.

- 15.4 For the avoidance of doubt, a notice shall not be required to be published or announced in respect of an event contemplated under Conditions 6, 8, 9, 10 or 11, as the case may be, if no adjustment to the rights of the Holders or amendment to the terms and conditions of the relevant Structured Warrants is made or to be made pursuant thereto.

16 Modification of rights

- 16.1 All or any of the rights for the time being attached to the Structured Warrants (other than the Exercise Price which a Holder is entitled to or the formulae for the adjustment of the Exercise Price or the Exercise Ratio or any other condition, which may be modified in accordance with the provisions set out elsewhere in these Conditions) may be altered or abrogated by the Issuer from time to time (whether or not the Issuer is being wound up), and the sanction of a Special Resolution passed at a meeting of the Holders held as aforesaid shall be necessary to effect such alteration or abrogation.

- 16.2 Notwithstanding Condition 16.1, the Issuer may without the consent of the Holders but in accordance with the terms of the Deed Poll, effect any modification to the Structured Warrants or the Deed Poll which, in the opinion of the Issuer, is:

- (a) not materially prejudicial to the interests of the Holders; or
- (b) of a formal, minor or technical nature; or
- (c) necessary or expedient to correct a manifest error, or to comply with mandatory provisions of law; or
- (d) necessary or expedient to facilitate scripless trading in or exercise of the Structured Warrants or payment by way of electronic funds transfer as approved by the relevant government or statutory authorities in respect of the Structured Warrants or to amend the restrictions on transfer or exercise of the Structured Warrants to comply with the

ANNEXURE I PRINCIPAL TERMS OF THE DEED POLL (cont'd)

requirements of or the concessions granted by any relevant government or statutory authorities.

Any such modification shall be binding on all Holders and shall be notified by the Issuer to them as soon as practicable thereafter in accordance with Condition 15 but in any event not later than twenty (20) Market Days from the date of such modification.

- 16.3 Notwithstanding Condition 16.1, the Issuer may, at any time and from time to time for the purpose of an issue of new Structured Warrants or a new Series of Structured Warrants through the Base Prospectus and without the consent or sanction of the Holders supplement the Deed Poll with the terms and conditions of the new Structured Warrants or Series of Structured Warrants (as set out in the relevant Term Sheet), as the case may be. In the event such supplement to the Deed Poll shall affect the rights and interests of the Holders, the Issuer is to effect such supplement to the Deed Poll by notice to the Holders in accordance with Condition 15 and such supplement shall be binding on all Holders without any further action being required to be taken by the Issuer. For the avoidance of doubt, a Holder is deemed to have notice of all announcements (and their respective contents) made by the Issuer to Bursa Securities in respect of or affecting the Series of Structured Warrants held.

17 Warrant Agency Agreement

- 17.1 The Structured Warrants Registrar acts as an agent of the Issuer and shall not assume any obligation or duty to or any relationship of agency or trust for the Holders except only as described in Condition 17.2.
- 17.2 The Warrant Agency Agreement contains provisions for the indemnification of the Structured Warrants Registrar. The Structured Warrants Registrar shall not be liable to any Holder in respect of any losses, liabilities, costs, claims, actions or demands which such Holder may suffer or incur or allege to have suffered or incurred as a result of or in connection with the exercise or non-exercise of any Structured Warrants Registrar's powers, discretions and/or duties. The Structured Warrants Registrar may:
- (a) in the exercise of its powers, discretions and/or duties, act on the advice or opinion of, or any certificate or information obtained in good faith from, any lawyer, valuer, accountant, banker, broker, securities company or other expert whether obtained by the Issuer, the relevant Structured Warrants Registrar or otherwise (which advice, opinion, certificate or information may be sent or obtained by letter, email, telex, telegram, cable or facsimile device) and the Structured Warrants Registrar shall not be liable for any loss occasioned by acting in good faith on any such advice, opinion, certificate or information unless there are reasonable grounds for concluding that the same may be forged or otherwise not authentic or containing some errors with respect to content, delivery or transmission;
 - (b) receive and retain without liability to account, such fee or other remuneration as may from time to time be agreed between the Issuer and the Structured Warrants Registrar; and
 - (c) enter into or be interested in any contract or financial or other transaction or arrangement with the Issuer or any person or body corporate associated with the Issuer in connection therewith to receive and retain, without liability to account any profit, fee, remuneration or other benefit received thereby or in connection therewith.

The Structured Warrants Registrar does not act as the agent of any Holder and therefore owes no fiduciary duty to any Holder in arriving at its calculations and determinations.

18 Exclusion of equities

- 18.1 Subject to the Central Depositories Act, the Rules of Bursa Depository, the Deed Poll, or these Conditions, no person shall be recognised by the Issuer as holding any Structured Warrants upon any trust, and the Issuer shall not be bound by or compelled in any way to recognise any equitable, contingent, future or partial interest in any Structured Warrant, or any interest in any fractional part of a Structured Warrant, or (except only as by these presents or by law otherwise provided) any other right in respect of any Structured Warrants, except an absolute right to the entirety thereof in the registered holder.

ANNEXURE I PRINCIPAL TERMS OF THE DEED POLL (cont'd)

19 Force Majeure

19.1 If the Issuer determines that, for reasons beyond the Issuer's control, the performance of the Issuer's obligations under the Structured Warrants has become illegal or impractical in whole or in part for any reason, or the Issuer determines that, for reasons beyond the Issuer's control, it is no longer legal or practical for the Issuer to maintain the Issuer's hedging arrangements with respect to the Structured Warrants for any reason, the Issuer may in the Issuer's discretion and without obligation terminate the Structured Warrants early by giving notice to the Holders in accordance with Condition 15.

20 Governing law

20.1 The Structured Warrants and the Deed Poll are governed by and shall be construed in accordance with the laws of Malaysia. The Issuer and the Holders irrevocably agree that with respect to any proceedings in Malaysia in connection with any matter or issue relating to the Deed Poll and these Conditions, they shall be bound by the decision, ruling or order of the Malaysian Court.

(the remainder of this page is intentionally left blank)

PART 6

CONDITIONS OF THE PHYSICAL-SETTLED EXCHANGE-TRADED FUND CALL WARRANTS

1 General, Nature, Form, Transfer, Administration and Status of Structured Warrants

- 1.1 The Structured Warrants comprise **American or European style non-collateralised physical-settled call warrants over a single exchange-traded fund** to be issued from time to time by the Issuer through the Base Prospectus and subject to, and with the benefit of the Deed Poll referred to on the face of the Structured Warrant Certificate and these Conditions. The Exercise Rights entitle the Holder of each Structured Warrant for each Series of Structured Warrants issued or to be issued, subject to the Deed Poll and in accordance with these Conditions, upon valid exercise thereof, to the Physical Settlement Amount, Cash Settlement Amount for Odd Lots, and/or Cash Settlement Amount, as the case may be, calculated in accordance with Condition 2. Certain statements in these Conditions are summaries of and are subject to the detailed provisions of the Deed Poll and in the event of any inconsistency between a provision contained in these Conditions and a provision contained in the Deed Poll, the provisions in the Deed Poll shall prevail. The Issuer has entered into a Warrant Agency Agreement with the Structured Warrants Registrar. Copies of the Deed Poll and the Warrant Agency Agreement are available for inspection at the registered office of the Issuer, being at the date hereof at 22nd Floor, Bangunan AmBank Group, No. 55 Jalan Raja Chulan, 50200 Kuala Lumpur, Malaysia. The Holders for the time being of the Structured Warrants and whose names appear on the Record of Depositors are all entitled to the benefit of, bound by, and deemed to have notice of, all the provisions of the Deed Poll and the Warrant Agency Agreement. Further, each Holder acknowledges it has, where necessary, consulted its stockbroker, solicitor or other adviser before investing in the Structured Warrants and none of the Issuer or its directors or employees may be construed as investment adviser or agent of, or owe any fiduciary duty to the Holder. **For the purposes of this Part 6, the term "Structured Warrants" shall refer to the American or European style non-collateralised physical-settled call over a single exchange-traded fund.**
- 1.2 Subject to the Central Depositories Act, the Rules of Bursa Depository, the Deed Poll, the relevant applicable rules and regulations and these Conditions:
- (a) each Structured Warrant is an option which confers on the Holder the Exercise Rights which require the Issuer to pay the Cash Settlement Amount to the Holder in accordance with these Conditions; and
 - (b) the Structured Warrants are issued in registered form, serially numbered and are a Prescribed Security to be admitted to the Official List. The Structured Warrants are represented by a global/jumbo certificate issued to Bursa Depository or its nominee who holds the same as bare trustee on behalf of the Holders, and deposited with Bursa Depository in or substantially in the form set out in the First Schedule to the Deed Poll as the same may from time to time be modified in accordance with the Deed Poll.
- 1.3 Subject to all information provided by the subscriber for the Structured Warrants to the Issuer being complete and consistent with the records of Bursa Depository, the Issuer shall within seven (7) Market Days from the date of allotment of the Structured Warrants, cause and procure the Structured Warrants Registrar to notify Bursa Depository of the names of the Holders together with such particulars as may be required by Bursa Depository for the purpose of making appropriate entries in the Securities Account of the respective Holder, request Bursa Depository to credit the Securities Account of the Holders with the applicable Structured Warrants and shall deliver to Bursa Depository the Structured Warrant Certificate registered in the name of Bursa Depository or its nominee company in such manner as may be prescribed by the Rules of Bursa Depository or agreed with Bursa Depository. If, at any time, the information provided by the Holders for the Structured Warrants is incorrect or inaccurate or inconsistent with the records of Bursa Depository, the Issuer reserves the right and without any obligation whatsoever to the Holders, to accept, reject or otherwise deal with the Structured Warrants in such manner as it reasonably deems fit in the circumstances. The Holders are not entitled to any physical warrant certificates.
- 1.4 Subject to the provisions of the Central Depositories Act and the Rules of Bursa Depository, the registration and subsequent administration of Structured Warrants shall be in the manner set forth in the Deed Poll and the Warrant Agency Agreement. It is hereby acknowledged that the Issuer

ANNEXURE I PRINCIPAL TERMS OF THE DEED POLL (cont'd)

shall be entitled to appoint registrars for the registration and administration of the Structured Warrants. The Issuer hereby confirms that it shall/has appointed the Structured Warrants Registrar for the purpose stipulated hereof, who shall perform such duties as required by the Issuer under the Deed Poll.

- 1.5 The Holders may transfer the Structured Warrants in the manner prescribed under the Central Depositories Act and the Rules of Bursa Depository. Subject to the provisions of the Central Depositories Act and the Rules of Bursa Depository, the Structured Warrants shall be freely transferable but the trading of the Structured Warrants must be in the same board lot applicable to the trading of the Underlying ETF or in such odd lots as permitted by the SC and/or Bursa Securities. Where the board lot of the Underlying ETF is more than one hundred (100) units per board lot, the Structured Warrants may be issued in board lots of one hundred (100) warrants.
- 1.6 The Structured Warrants and the settlement obligation of the Issuer in respect of the Structured Warrants represent general and unsecured contractual obligations of the Issuer and of no other person which rank, and shall rank, equally among themselves and without preference in all respects, subject to such exceptions as may from time to time exist under applicable law or the Deed Poll, with the other existing and future unsecured and unsubordinated obligations of the Issuer.
- 1.7 The Holders of the Structured Warrants are entitled to the Physical Settlement Amount, Cash Settlement Amount for Odd Lots and/or Cash Settlement Amount, as the case may be, in accordance with Condition 2 provided always that the settlement to the Holder shall be in cash if the Underlying ETF is securities quoted on a Securities Exchange outside Malaysia.

2 Exercise of the Structured Warrants**2.1 Exercise Rights****2.1.1 (a) American style Structured Warrants**

The Structured Warrants may be exercised in the manner set out in Condition 2.1.2 from the date of issue up to and including the Expiry Date. In the event the date whereby the Exercise Form is delivered is not a Market Day, then it shall be deemed to be exercised on the next following Market Day.

(b) European style Structured Warrants

The Structured Warrant may be exercised in the manner as set out in Condition 2.1.2 on the Expiry Date up to 9.00 a.m. on the fifth (5th) Market Day following the Expiry Date. If the Expiry Date is not a Market Day then it shall be deemed to be exercised on the next following Market Day.

- 2.1.2 In order to invoke the Exercise Rights, within the Exercise Period a Holder must complete and sign the Exercise Form (which shall be made available by the Structured Warrants Registrar in any manner as may be stipulated by Bursa Securities or such other relevant authority) and deliver the same on a Market Day between 9.00 a.m. to 5.00 p.m. to the Structured Warrants Registrar who shall acknowledge receipt by stamping the date and time of receipt on the Exercise Form in respect of which the Structured Warrants are being exercised.

Provided always that:

- (a) (i) in respect of American style Structured Warrants, the payment by remittance of bankers' draft for the credit of the Issuer for the amount equal to the Exercise Price for all the Underlying ETF in respect of the Structured Warrants being exercised together with the transfer fee for Bursa Depository or such other fee as may be imposed by the relevant authority from time to time is received by the issuer on the same Market Day of the receipt of the Exercise Form;

(ii) in respect of European style Structured Warrants, the Exercise Form is received by the Warrant Registrar and the payment by remittance of bankers' draft for the credit of the Issuer for the amount equal to the Exercise Price for all the Underlying ETF in respect of the Structured Warrants being exercised together with the transfer fee for Bursa Depository or such other fee as may be imposed by the

ANNEXURE I **PRINCIPAL TERMS OF THE DEED POLL** (*cont'd*)

relevant authority from time to time is received by the issuer, by 9.00 a.m. on the fifth (5th) Market Day following the Expiry Date;

- (b) in every case compliance must also be made with the requirements set out in the Exercise Form and other prevailing statutory requirements for the time being applicable;
- (c) the Holder shall, if so required by the Structured Warrants Registrar, furnish such evidence, if any, as the Structured Warrants Registrar or the directors of the Issuer may require to determine the due execution of the Exercise Form by or on behalf of the Holder exercising the same. Once a valid Exercise Form is duly delivered by the Holder to the Structured Warrants Registrar and the payment is duly delivered by the Holder to the Issuer, the exercise of such Exercise Rights shall be irrevocable save with the consent of the directors of the Issuer; and
- (d) where the Holder does not comply with the procedures or restrictions or conditions relating to the exercise of the Structured Warrants, the Exercise Form and any documents received shall be returned to such Holder by ordinary post to the Holder's address recorded in the Record of Depositors at the risk of the Holder.

- 2.1.3 Subject to notification by the Structured Warrants Registrar of fulfilment of the preconditions by the Holder to validly exercise the Structured Warrants as set out in Condition 2.1.2 within three (3) Market Days from the Exercise Date and the absence of a Settlement Disruption Event, the Issuer shall, within seven (7) Market Days from the Exercise Date or such other period as may be prescribed by Bursa Securities or such other relevant authority, deliver the Physical Settlement Amount comprising the relevant Underlying ETF to the exercising Holder by crediting the relevant number of Underlying ETF at the Exercise Ratio to the exercising Holder's Securities Account and despatch the notice of transfer to the Holder.

Provided always that the delivery of the Underlying ETF shall not be effected until the Issuer is satisfied that Exercise Price and Exercise Expenses, if any, have been received or shall be received by the Issuer from the Holder.

- 2.1.4 The Physical Settlement Amount shall be calculated based on the Exercise Ratio. All determinations made by the Issuer (in the absence of manifest error) shall be final and conclusive and binding on the Holders. If a book closure date has been declared by the Underlying ETF and trading in the Underlying ETF is on a "cum-entitlement" basis on the Exercise Date, the Underlying ETF to be delivered by the Issuer to the Holder upon valid exercise of the Structured Warrants shall also be on a "cum-entitlement" basis.
- 2.1.5 In the event the Holder is entitled to receive odd lots of the Underlying ETF upon valid exercise of the Structured Warrants, the Issuer shall pay to the relevant Holder, in respect of such odd lots of the Underlying Equity, the Cash Settlement Amount for Odd Lots less all Exercise Expenses, if any, in the absence of a Settlement Disruption Event, within seven (7) Market Days from the Exercise Date or such other period as may be prescribed by Bursa Securities or such other relevant authority. The Cash Settlement Amount for Odd Lots less all Exercise Expenses, if any, is calculated as follows:

$$\text{Cash Settlement Amount for Odd Lots} = \text{Number of Underlying ETF in odd lots} \times \text{Closing Price}^{(1)}$$

- (1) As set out in Condition 2.1.7.

- 2.1.6 The Issuer shall be discharged from its obligation to deliver the Underlying ETF to the relevant Holders upon despatching the notice of transfer and making Cash Settlement Amount for Odd Lots (if any), to the exercising Holders in accordance with these Conditions.

- 2.1.7 (a) American style Structured Warrants

In the event the Issuer is unable to deliver the Underlying ETF upon valid exercise of the Structured Warrants by the Holders for reasons set out in Condition 2.1.11, and provided that the Cash Settlement Amount after deduction of the Exercise Expenses, if any, is greater than zero, the Issuer shall pay the Holders the Cash

ANNEXURE I

PRINCIPAL TERMS OF THE DEED POLL (cont'd)

Settlement Amount less Exercise Expenses, if any, in the absence of a Settlement Disruption Event, within seven (7) Market Days from the Exercise Date or such other period as may be prescribed by Bursa Securities or such other relevant authority. The Cash Settlement Amount less all Exercise Expenses, if any, is calculated as set out below:

$$\text{Cash Settlement Amount} = \text{Number of Structured Warrants} \times \left(\frac{\text{Closing Price}^{(1)} - \text{Exercise Price}^{(2)}}{\text{Exercise Ratio}^{(2)}} \right) \times \text{Settlement Exchange Rate (if applicable)}$$

(1) The Settlement Price shall be calculated by reference to either:

(a) In the event a valid Exercise Form is received in accordance with Condition 2.1.2 by the Warrant Registrar:

(i) before 12.30 p.m. on any Market Day other than on the Expiry Date, the exercise of the Structured Warrants shall be deemed to have been made on that Market Day and in such instance the Market Day of receipt of the Exercise Form shall be the Exercise Date and Valuation Date and the Closing Price shall be the closing price of the Underlying ETF on such Valuation Date; or

(ii) on or after 12.30 p.m. on any Market Day other than on the Expiry Date, the exercise of the Structured Warrants shall be deemed to have been made on the Market Day immediately following the Market Day of receipt of the Exercise Form and in such instance the Market Day immediately following the Market Day of receipt of the Exercise Form shall be the Exercise Date and the Valuation Date and the Closing Price shall be the closing price of the Underlying ETF on such Valuation Date. For the avoidance of doubt, if a valid Exercise Form is received on or after 12.30 p.m. on a Market Day immediately preceding the Expiry Date, the exercise of the Structured Warrants shall be deemed to have been made on the Expiry Date and in such instance the Closing Price shall be the Expiry Date Closing Price (as defined below) of the Underlying ETF; or

(iii) on the Expiry Date, the Closing Price shall be the Expiry Date Closing Price (as defined below) of the Underlying ETF,

and as specified in the relevant Term Sheet and subject to the Market Disruption Event provision below.

If the Underlying ETF is delisted, the Closing Price shall be determined in accordance with Condition 9.

If the Exercise Date falls on a Market Day when the Underlying ETF is suspended from trading for any reason, the Closing Price shall be the last quoted price of such Underlying ETF immediately before the suspension (subject to the Market Disruption Event provision below).

(b) In the event of any exercise of the Structured Warrants on the Expiry Date, the Closing Price shall be calculated by reference to either:

(i) the average VWAP of the Underlying ETF (subject to any adjustment as may be necessary to reflect any capitalisation, rights issue, distribution or others) for the five (5) Market Days prior to and including the Market Day immediately before the Expiry Date; or

(ii) the average closing price of the Underlying ETF (subject to any adjustment as may be necessary to reflect any capitalisation, rights issue, distribution or others) for the five (5) Market Days

ANNEXURE I

PRINCIPAL TERMS OF THE DEED POLL (cont'd)

prior to and including the Market Day immediately before the Expiry Date; or

- (iii) the closing price of the Underlying ETF on the Market Day immediately before the Expiry Date,

and as specified in the relevant Term Sheet ("**Expiry Date Closing Price**") and subject to the Market Disruption Event and other provisions herein.

In the event the Underlying ETF is delisted, the Expiry Date Closing Price shall be determined in accordance with Condition 9 below.

- (c) If a Market Disruption Event, or a public holiday unexpected by the Issuer occurs on any of the five (5) Market Days described in sub-Conditions (1)(b)(i) or (1)(b)(ii) above, the valuation period applicable and the Closing Price shall be as determined by the Issuer in such manner as it reasonably deems fit.

In any other cases where there is a single Valuation Date, if there is a Market Disruption Event on the Valuation Date, the Valuation Date shall be the next following Market Day after the Market Disruption Event. If the Market Disruption Event continues to occur up to the eighth (8th) Business Day following the original Valuation Date, then the Valuation Date shall be:

- (i) that eighth (8th) Business Day; and
- (ii) the Issuer shall determine as it reasonably deems fit and on the basis of the Issuer's good faith estimate the reference price and/or the exchange rate (if applicable) for that Valuation Date by determining the price of the Underlying ETF and/or the exchange rate (if applicable) based on the prevailing market conditions and other factors as the Issuer may consider relevant.

- (2) The Exercise Price and/or Exercise Ratio shall be subject to such adjustments as may be necessary as provided in Condition 6. If the Holder has paid the Exercise Price, the Exercise Price shall be excluded from the calculation of the Cash Settlement Amount for Structured Warrants.

- (b) European style Structured Warrants

In the event the Issuer is unable to deliver the Underlying ETF upon valid exercise of the Structured Warrants by the Holders as a result of the events set out in Condition 2.1.11 and provided that the Cash Settlement Amount for the Structured Warrants after deduction of the Exercise Expenses, if any, is greater than zero, the Issuer shall pay the Holders the Cash Settlement Amount for the Structured Warrants less Exercise Expenses, if any, in the absence of a Settlement Disruption Event, within seven (7) Market Days from the Expiry Date or such other period as may be prescribed by Bursa Securities or such other relevant authority. The Cash Settlement Amount for the Structured Warrants less Exercise Expenses, if any, is calculated as set out below:

$$\text{Cash Settlement Amount} = \text{Number of Structured Warrants} \times \frac{(\text{Closing Price}^{(1)} - \text{Exercise Price}^{(2)})}{\text{Exercise Ratio}^{(2)}} \times \text{Settlement Exchange Rate (if applicable)}$$

- (1) (a) The Closing Price on the Expiry Date shall be calculated by reference to either:

- (i) the average VWAP of the Underlying ETF (subject to any adjustment as may be necessary to reflect any capitalisation, rights issue, distribution or others) for the five (5) Market

ANNEXURE I

PRINCIPAL TERMS OF THE DEED POLL (cont'd)

Days prior to and including the Market Day immediately before the Expiry Date; or

- (ii) the average closing price of the Underlying ETF (subject to any adjustment as may be necessary to reflect any capitalisation, rights issue, distribution or others) for the five (5) Market Days prior to and including the Market Day immediately before the Expiry Date; or
- (iii) the closing price of the Underlying ETF on the Market Day immediately before the Expiry Date,

and as specified in the relevant Term Sheet and subject to the Market Disruption Event and other provisions herein.

If the Underlying ETF is delisted, the Closing Price shall be determined in accordance with Condition 9 below.

- (b) If a Market Disruption Event, or a public holiday unexpected by the Issuer occurs on any of the five (5) Market Days described in sub-Conditions (1)(a)(i) or (1)(a)(ii) above, the valuation period applicable and the Closing Price shall be as determined by the Issuer as it reasonably deems fit.

In any other cases where there is a single Valuation Date, if there is a Market Disruption Event on the Valuation Date, the Valuation Date shall be the next following Market Day after the Market Disruption Event. If the Market Disruption Event continues to occur up to the eighth (8th) Business Day following the original Expiry Date, then the Expiry Date shall be:

- (i) that eighth (8th) Business Day; and
- (ii) the Issuer shall determine as it reasonably deems fit and on the basis of the Issuer's good faith estimate the reference price and/or the exchange rate (if applicable) for that Expiry Date by determining the price of the Underlying ETF and/or the exchange rate (if applicable) based on the prevailing market conditions and other factors as the Issuer may consider relevant.

- (2) The Exercise Price and/or Exercise Ratio shall be subject to such adjustments as may be necessary as provided in Condition 6. If the Holder has paid the Exercise Price, the Exercise Price shall be excluded from the calculation of the Cash Settlement Amount for the Structured Warrants.

2.1.8 Where the Issuer makes payment to a Holder pursuant to the terms of this Condition 2.1:

- (a) the payment of Cash Settlement Amount less the Exercise Expenses or Cash Settlement Amount for Odd Lots less Exercise Expenses shall be made by way of cheque drawn in favour of the Holder to be delivered by ordinary post to the Holder's address last recorded in the Record of Depositors at the Holder's own risk or by way of electronic transfer of funds to the bank account of the Holder; and/or
- (b) the payment of Physical Settlement Amount shall be made by crediting such amount by the Issuer, directly or indirectly to the Holder's Securities Account,

the details of which are provided by Bursa Depository to the Issuer at the request of the Issuer. The Holder shall be deemed to have authorised Bursa Depository to disclose information of the Holder's Securities Account for the purpose of such payments.

Where the Issuer makes a payment to a Holder pursuant to the terms of this Condition 2.1, the amount of such payment arising from the exercise of the Structured Warrants shall be final and conclusive and the Issuer shall be discharged from its obligation upon making such payment thereof in accordance with these Conditions.

ANNEXURE I **PRINCIPAL TERMS OF THE DEED POLL** (cont'd)

- 2.1.9 The Cash Settlement Amount for Odd Lots less the Exercise Expenses, if any, or the Cash Settlement Amount less the Exercise Expenses, if any, shall be calculated and be payable in Settlement Currency and rounded down to the nearest two (2) decimal points. All determinations made by the Issuer pursuant to this Condition 2.1 shall be final and conclusive and binding on the Holders.
- 2.1.10 In the event that the Cash Settlement Amount for Odd Lots after deduction of the Exercise Expenses, if any, or the Cash Settlement Amount after deduction of the Exercise Expenses, if any, is equal to or less than zero, the Issuer shall not be obliged to make any payment to the relevant Holder, and the Structured Warrants exercised shall thereafter become void and cease to have the Exercise Rights and the Issuer's obligations in respect of the Structured Warrants shall terminate absolutely. For the avoidance of doubt, the Holder shall not be required to pay or top-up the Exercise Expenses, if any, as the case may be, where the Cash Settlement Amount after deduction of the Exercise Expenses, if any, is less than zero.
- 2.1.11 The events that would result to the Issuer being unable to settle the Structured Warrants by way of Physical Settlement Amount are liquidation, dissolution or winding-up of the Underlying ETF as referred to in Condition 10 or the Underlying ETF is suspended or delisted upon valid exercise of the Structured Warrants by the Holders as referred to in Condition 9. Upon occurrence of any of these events, the Issuer shall make the necessary announcement prior to Expiry Date, that the Structured Warrants shall be cash-settled.
- 2.1.12 In respect of American style Structured Warrants, any unexercised Structured Warrants shall be automatically terminated and cease to have the Exercise Rights after 5.00 p.m. on the Expiry Date. In respect of European-style Structured Warrants, any unexercised Structured Warrants shall be automatically terminated and cease to have the Exercise Rights after 9.00 a.m. on the fifth (5th) Market Day following.
- 2.1.13 The Holder is to bear all Exercise Expenses, if any, in relation to the exercise of Structured Warrants and on exercise of the Structured Warrants, the Issuer shall be irrevocably authorised by the Holders to deduct all Exercise Expenses, if any, from the Cash Settlement Amount for Odd Lot or the Cash Settlement Amount.
- 2.1.14 If as a result of a Settlement Disruption Event, it is not possible for the Issuer to make payment on the original Settlement Date, the Issuer shall use its reasonable endeavours to procure payment as soon as practicable after the original Settlement Date. The Issuer shall not be liable to the Holder for any interest in respect of the amount due or any loss or damage that such Holder may suffer as a result of the existence of the Settlement Disruption Event.
- 2.2 The Issuer shall not allow the Holder to exercise the Exercise Rights unless the Structured Warrants are or have been designated as "free securities" in accordance with the Rules of Bursa Depository.
- 2.3 The Issuer declares that approval shall be sought from Bursa Securities for the admission of the Structured Warrants to the Official List and for the listing of and quotation for the Structured Warrants on Bursa Securities.
- 2.4 All questions as to the validity, form, eligibility (including time of receipt) and acceptance of Exercise Form shall be resolved by the Structured Warrants Registrar as it reasonably deems fit, whose determination shall be final and binding on the Issuer and the Holder. The Structured Warrants Registrar reserves the absolute right to reject any Exercise Form that is not in proper form or the acceptance of which may, in the view of counsel for the Structured Warrants Registrar be unlawful. The Structured Warrants Registrar also reserves the absolute right, subject to applicable law, to waive any irregularities. The interpretation of the Structured Warrants Registrar of the terms and conditions of exercise of the Structured Warrants shall be final and binding on the Issuer and the Holder. Unless waived, any irregularities in connection with the Exercise Form must be rectified by such time, as the Structured Warrants Registrar shall determine. The Structured Warrants Registrar shall not be under any duty to give notification of any irregularities in such Exercise Form and shall not incur liabilities for failure to give such notification. The Exercise Form shall not be considered to have been validly delivered until such irregularities have been rectified and waived.

ANNEXURE I PRINCIPAL TERMS OF THE DEED POLL (cont'd)

- 2.5 The initial Structured Warrants Registrar and its specified offices are stated in the Deed Poll. The Issuer reserves the right at any time to terminate the appointment of the Structured Warrants Registrar. Prior written notice of any termination, appointment of Structured Warrants Registrar, resignation of the Structured Warrants Registrar or any changes in any of the specified offices of the relevant Structured Warrants Registrar shall be given to the Holders in accordance with Condition 15 and such prior notice shall be given to the Holders not more than sixty (60) days and less than thirty (30) days of such termination, appointment, resignation or change.
- 2.6 In respect of each Structured Warrant in which Exercise Rights have been exercised, the Issuer shall instruct or procure the Structured Warrants Registrar to instruct Bursa Depository, in accordance with the Central Depositories Act and the Rules of Bursa Depository, to debit the appropriate number of Structured Warrants in respect of which Exercise Rights have been exercised from the Securities Account of such Holder. The Issuer shall be entitled at any time on or after the Expiry Date, to demand that Bursa Depository deliver to the Issuer the Structured Warrant Certificates and thereafter cancel or cause the cancellation of the Structured Warrant Certificates.
- 2.7 The Structured Warrants subject to the Exercise Rights which have been exercised in accordance with the Deed Poll shall cease to exist and all obligations of the Issuer in respect of those Structured Warrants shall terminate absolutely following payment of the amount (if any) referred to in this Condition 2.

3 Exercise Rights and Suspension

- 3.1 Upon and subject to the provisions of the Central Depositories Act, the Rules of Bursa Depository and the Deed Poll, the Holder whose name as stated in the Record of Depositors shall have the right at any time during the Exercise Period to invoke its Exercise Rights at the Exercise Price subject to adjustments in accordance with Condition 6.
- 3.2 The Structured Warrants shall, subject to any directions, order or notice from any relevant regulatory authority and any request for suspension by the Issuer which is not rejected by any such relevant regulatory authority, continue to be traded notwithstanding that the trading of the Underlying ETF may have been suspended. Any suspension in the trading of the Underlying ETF or the Structured Warrants shall not preclude the Holder from exercising the Exercise Rights.
- 3.3 The Issuer shall notify the Holders of the Expiry Date at least one (1) month prior to the Expiry Date or such other period as may be specified by the relevant authority. Such notice shall be given in accordance with Condition 15 stating the Expiry Date and treatment of the Structured Warrants which are not exercised.

4 Deposit and Forfeiture of Unclaimed Amount

- 4.1 In the event that the Issuer pays the Cash Settlement Amount to any Holder under Condition 2 and such Holder does not present the cheque for payment within six (6) months from the date of the cheque, the Issuer shall at any time thereafter deal with the said monies in accordance and in compliance with, the requirements of the Unclaimed Moneys Act 1965 (Act 370) (revised 1989) of Malaysia.

5 Designation of Structured Warrants set out in the Exercise Form

- 5.1 Subject to the approval of Bursa Depository and/or other relevant authority, the Issuer reserves all rights to instruct Bursa Depository and/or other relevant authority to designate the Structured Warrants held in the relevant Securities Account of a Holder which the Holder has purportedly exercised by submitting an Exercise Form to the Issuer and/or the Structured Warrants Registrar, in order for Bursa Depository and/or the relevant authority to prohibit the Holder from trading on the exchange the designated Structured Warrants after the aforesaid exercise. The Issuer's right to instruct Bursa Depository and/or the relevant authority shall be independent of whether the exercise is valid or otherwise, provided that the amount of Structured Warrants so designated by Bursa Depository and/or the relevant authority do not exceed the amount set out in such Exercise Form.

ANNEXURE I **PRINCIPAL TERMS OF THE DEED POLL** (cont'd)**6 Adjustment of Exercise Price and/or Exercise Ratio**

6.1 Adjustments

Subject to the Conditions as hereinafter provided and the Deed Poll, the Exercise Price and/or the Exercise Ratio shall from time to time be adjusted in accordance with the following provisions:

(a) Bonus Issue

If and whenever there is an issue of new units credited as fully paid-up to the holders of units generally (other than pursuant to a scrip distribution or similar scheme for the time being or otherwise in lieu of a cash distribution and without any payment or other consideration being made or given by such holders) ("**Bonus Issue**"), the Exercise Price and/or Exercise Ratio shall be adjusted on the Market Day immediately following the last day on which an instrument of transfer could be lodged so that the transferee of the units would qualify for the Bonus Issue in accordance with the following formula:

$$(i) \quad \text{Adjusted Exercise Ratio} = \frac{E}{(1 + N)}$$

$$(ii) \quad \text{Adjusted Exercise Price} = \frac{X}{(1 + N)}$$

Whereby in respect of this Condition 6.1(a)(i) and (ii):

X = Existing Exercise Price immediately prior to the Bonus Issue.

N = The number of additional units (whether a whole or a fraction) received by a holder of existing units for each unit held prior to the Bonus Issue.

E = Existing Exercise Ratio immediately prior to the Bonus Issue.

Alternatively, the Issuer may also, in good faith, make a corresponding adjustment to the Exercise Ratio and/or Exercise Price as the Issuer determines appropriate to account for the dilutive effect of the Bonus Issue.

On any such adjustment, the resultant Exercise Ratio and/or Exercise Price shall be rounded to the nearest four (4) decimal points of the Relevant Currency and all such adjustment made by the Issuer pursuant to this Condition shall be deemed as final and conclusive save for any manifest error.

(b) Distribution Payment

Should the Underlying ETF of the relevant Structured Warrants undertake a special distribution payment in cash during the tenure of the Structured Warrants, the Exercise Price and/or the Exercise Ratio of the Structured Warrants may be adjusted (as the Issuer reasonably deems fit) on the Market Day following the last day on which an instrument of transfer is lodged to enable the transferee of the Underlying ETF to qualify for the special distribution payment by the amount of the special distribution payment, net of taxation, if any.

The Exercise Ratio and/or Exercise Price for the Structured Warrants shall be adjusted in accordance with the following formula:

$$(i) \quad \text{Adjusted Exercise Ratio} = E \times \frac{(P - D)}{P}$$

ANNEXURE I **PRINCIPAL TERMS OF THE DEED POLL** (cont'd)

(ii) Adjusted Exercise Price =

$$X \times \frac{(P - D)}{P}$$

Whereby, in respect of this Condition 6.1(b)(i) and (ii):

- P = Closing Price of the Underlying ETF on the last market day on which the Underlying Equity is traded on a cum-entitlement basis.
- D = The special distribution amount per one (1) Underlying ETF unit held.
- X = Existing Exercise Price immediately prior to the special distribution payment.
- E = Existing Exercise Ratio immediately prior to the special distribution payment.

Alternatively, the Issuer may also, in good faith, make a corresponding adjustment to the Exercise Ratio and/or Exercise Price as the Issuer determines appropriate to account for the effect of the special distribution payment.

On any such adjustment, the resultant Exercise Ratio and/or Exercise Price shall be rounded to the nearest four (4) decimal points of the Relevant Currency and all such adjustment made by the Issuer pursuant to this Condition shall be deemed as final and conclusive save for any manifest error.

The Exercise Ratio and/or Exercise Price of the Structured Warrants shall not be adjusted for distribution payment in specie or in the form of other securities, other than for bonus issue pursuant to Condition 6.1(a).

(c) Subdivision or Consolidation

If and whenever there is a subdivision of units or any class of outstanding units into a greater number of units (a "**Subdivision**"), or consolidation of the units or any class of its outstanding units into a smaller number of units (a "**Consolidation**"), the Exercise Price and/or the Exercise Ratio shall be adjusted on the Market Day on which the relevant Subdivision or Consolidation shall have taken effect in accordance with the following formula:

(i) Adjusted Exercise Ratio =

$$\frac{E \times N}{P}$$

(ii) Adjusted Exercise Price =

$$\frac{X \times N}{P}$$

Whereby, in respect of this Condition 6.1(c)(i) and (ii):

- X = Existing Exercise Price immediately prior to the Subdivision or Consolidation.
- N = Revised par value after the Subdivision or Consolidation.
- P = Existing par value immediately prior to the Subdivision or Consolidation.
- E = Existing Exercise Ratio immediately prior to the Subdivision or Consolidation.

ANNEXURE I**PRINCIPAL TERMS OF THE DEED POLL (cont'd)**

Alternatively, the Issuer may also, in good faith, make a corresponding adjustment to the Exercise Ratio and/or Exercise Price as the Issuer determines appropriate to account for the dilutive or consolidative effect of the Subdivision.

On any such adjustment, the resultant Exercise Price and/or Exercise Ratio shall be rounded to the nearest four (4) decimal points of the Relevant Currency and all such adjustment made by the Issuer pursuant to this Condition shall be deemed as final and conclusive save for any manifest error.

(d) Other adjustments

The Issuer is entitled to make other adjustments as it reasonably believes are appropriate in circumstances where an event or events occur which the Issuer believes (notwithstanding any adjustment previously made by the Issuer) should, in the context of the issue of Structured Warrants and its obligations hereunder, give rise to such adjustment. The Issuer shall make such adjustment generally without considering the individual circumstances of any Holder or the tax or other consequences of such adjustment in any particular jurisdiction.

On any such adjustment, the resultant Exercise Price and/or Exercise Ratio shall be rounded to the nearest four (4) decimal points of the Relevant Currency.

6.2 Notwithstanding the foregoing, no adjustments shall be made to the Exercise Price and/or Exercise Ratio if the formulae stated in Condition 6.1(a) to Condition 6.1(d) results in an adjustment which would amount to less than two percent (2%) of the Exercise Price and/or Exercise Ratio being changed.

6.3 Any termination of Structured Warrants or adjustment made pursuant to Conditions 6.1 and 6.2 shall be final and binding on the Holders save in the case of manifest error. Notice of such termination, adjustments or amendments shall be given to the Holders as soon as practicable thereafter in accordance with Condition 15 and in any event within five (5) Market Days of such termination or adjustment being made.

7 Restrictions to Protect Rights of Holders

7.1 As from the date of the issue of the Structured Warrants and for so long as any of the Structured Warrants remain exercisable, the Issuer shall have arrangements in place to ensure, for the benefit of the Holders that it is able to satisfy in full the exercise of all the Structured Warrants for the time being outstanding.

8 Merger or Consolidation of Underlying ETF

8.1 If it is announced that the Underlying ETF is to or may merge with or consolidate into any other fund, other collective investment scheme or otherwise or that all or substantially all of its assets are or may be sold or transferred, ("**Restructuring Event**") the Issuer may in good faith take any of the actions below:

(a) cancel the Structured Warrants without prior notice to the Holders. If the Structured Warrants are so cancelled, the Issuer shall pay an amount to each Holder if the Cash Settlement Amount after deduction of the Exercise Expenses, if any, is greater than zero (without the Holder having to deliver a valid Exercise Form). The Cash Settlement Amount shall be determined by the Issuer in a manner as it reasonably deems fit based on the fair market value of the Underlying ETF (as determined by the Issuer) after taking into account the Restructuring Event less all Exercise Expenses, if any; and/or

(b) amend and determine the appropriate adjustment, if any, to be made to the terms and conditions of the Structured Warrants to account for the Restructuring Event and determine the effective date of that adjustment. After such adjustments (if any), the Structured Warrants shall relate to the number of units resulting from or surviving such Restructuring Event or other securities ("**Substituted Securities**") and/or cash offered in substitution for the affected Underlying ETF of the relevant Structured Warrants to which the holder of such number of Underlying ETF to which the Structured Warrants related immediately before such Restructuring Event would have been entitled upon such Restructuring Event, as the case may be. The Issuer may, but need not, determine the appropriate adjustment

ANNEXURE I PRINCIPAL TERMS OF THE DEED POLL (cont'd)

by reference to the adjustment in respect of the Restructuring Event made by a Securities Exchange to options on the relevant Underlying ETF traded on that Securities Exchange.

- 8.2 Upon the occurrence of a Restructuring Event, the rights attaching to the Structured Warrants in respect of that Underlying ETF may be amended by the Issuer no later than the Market Day preceding the consummation of such Restructuring Event.
- 8.3 The provisions of these Conditions shall apply to such Substituted Securities provided that, any Substituted Securities may, as the Issuer reasonably deems fit, be replaced by an amount in the Relevant Currency equal to the market value or, if no market value is available, fair value, of such Substituted Securities in each case as determined by the Issuer as soon as practicable after such Restructuring Event is effected.
- 8.4 Any cancellation of Structured Warrants or modification of rights made pursuant to Condition 8.1 or 8.2 shall be notified to the Holders as soon as practicable thereafter and in any event within five (5) Market Days from the date of such cancellation or modification in accordance with Condition 15.

9 Delisting of the Underlying ETF

- 9.1 If at any time the Underlying ETF of the Structured Warrants ceases to be listed on Bursa Securities or such other Securities Exchanges or there is an announcement of an intention to cease the listing of the Underlying ETF or the Underlying ETF is suspended from trading on Bursa Securities or such other Securities Exchanges prior to, and in connection with the delisting of the Underlying ETF, the Structured Warrants may if determined by the Issuer be automatically exercised without the Holder having to deliver a valid Exercise Form and without notice of automatic exercise being given by the Issuer to the Holder:
- (a) if the Cash Settlement Amount after deduction of the Exercise Expenses, if any, is greater than zero, the Issuer shall make payment of the Cash Settlement Amount to the relevant Holder; or
- (b) if the Cash Settlement Amount after deduction of the Exercise Expenses, if any, is equal to or less than zero, the Issuer shall not be obliged to make any payment to the relevant Holder and the relevant Structured Warrants shall terminate and cease to be valid and the Issuer's obligations in respect of the Structured Warrants shall terminate absolutely. For the avoidance of doubt, the Holder shall not be required to pay or top-up the Exercise Expenses, if any, as the case may be, where the Cash Settlement Amount after deduction of the Exercise Expenses, if any, is less than zero.

The Closing Price for the calculation of the Cash Settlement Amount (calculated in accordance with Condition 2) shall be the last quoted price of the Underlying ETF immediately before such events or determined in accordance with Condition 2.1.7(a)(1)(b) or 2.1.7(b), as the case may be, and the Issuer shall not be obliged to make any adjustment to the Exercise Price.

Provided that if there is a Market Disruption Event on the date immediately before such events ("**Set Date**"), the Closing Price shall be based on the Market Day immediately preceding the Market Disruption Event. If the preceding Market Day is also affected by the Market Disruption Event, then the Closing Price shall be determined by the Issuer on the Set Date as it reasonably deems fit and on the basis of the Issuer's good faith estimate the reference price and/or the exchange rate (if applicable) for that Set Date by determining the price of the Underlying ETF and/or the exchange rate (if applicable) based on the prevailing market conditions and other factors as the Issuer may consider relevant.

- 9.2 Subject to the aforesaid, the Issuer may but shall not be obliged to make any adjustment to the terms and conditions of the Structured Warrants and the rights attaching to the Structured Warrants as it shall reasonably consider appropriate to ensure that the interests of the Holders generally are not materially prejudiced as a consequence of such events (without considering the individual circumstances of any Holder or the tax or other consequences that may result in any particular jurisdiction).

10 Liquidation, Dissolution or Winding-Up of the Underlying ETF

- 10.1 In the event of a liquidation, dissolution or winding-up of the Underlying ETF or the appointment of a liquidator, receiver or administrator or analogous person under any applicable law in respect of

ANNEXURE I PRINCIPAL TERMS OF THE DEED POLL (cont'd)

the whole or substantially the whole of the Underlying ETF's Assets, the Structured Warrants will be automatically exercised without the Holder having to deliver a valid Exercise Form and without notice of automatic exercise being given by the Issuer to the Holder:

- (a) if the Cash Settlement Amount after deduction of the Exercise Expenses, if any, is greater than zero, the Issuer shall make payment of the Cash Settlement Amount to the relevant Holder; or
- (b) if the Cash Settlement Amount after deduction of the Exercise Expenses, if any, is equal to or less than zero, the Issuer shall not be obliged to make any payment to the relevant Holder and the relevant Structured Warrants shall terminate and cease to be valid and the Issuer's obligations in respect of the Structured Warrants shall terminate absolutely. For the avoidance of doubt, the Holder shall not be required to pay or top-up the Exercise Expenses, if any, as the case may be, where the Cash Settlement Amount after deduction of the Exercise Expenses, if any, is less than zero.

The Closing Price for the calculation of the Cash Settlement Amount (calculated in accordance with Condition 2) shall be the closing price of the Underlying ETF on the Market Day immediately before such events or determined in accordance with Condition 2.1.7(a)(1)(b) or 2.1.7(b), as the case may be, and the Issuer shall not be obliged to make any adjustment to the Exercise Price.

Provided that if there is a Market Disruption Event on the date immediately before such events ("**Set Date**"), the Closing Price shall be based on the Market Day immediately preceding the Market Disruption Event. If the preceding Market Day is also affected by the Market Disruption Event, then the Closing Price shall be determined by the Issuer on the Set Date as it reasonably deems fit and on the basis of the Issuer's good faith estimate the reference price and/or the exchange rate (if applicable) for that Set Date by determining the price of the Underlying ETF and/or the exchange rate (if applicable) based on the prevailing market conditions and other factors as the Issuer may consider relevant.

- 10.2 Subject to the aforesaid, the Issuer may but shall not be obliged to make any adjustment to the terms and conditions of the Structured Warrants and the rights attaching to the Structured Warrants as it shall reasonably consider appropriate to ensure that the interests of the Holders generally are not materially prejudiced as a consequence of such events (without considering the individual circumstances of any Holder or the tax or other consequences that may result in any particular jurisdiction).

11 Takeover, Merger, Liquidation, Dissolution or Winding-Up of Issuer

- 11.1 In the event of a take-over or a scheme of arrangement or any other form of reorganisation undertaken by the Issuer or any other events having similar effects on the rights of the Holders, the Issuer is entitled to deal with the Structured Warrants in such manner as it reasonably deems fit in the circumstances and with or without any adjustments to the rights attaching to the relevant Structured Warrants.
- 11.2 In the event of a merger, amalgamation or reconstruction of the Issuer, the corporation, trust or other body into which the Issuer is merged, amalgamated or reconstructed shall assume all the liabilities and the obligations of the Issuer in respect of the Structured Warrants so that the rights of the Holders shall continue to exist and be enforceable to the same extent as provided by the Issuer under the Deed Poll.
- 11.3 In the event of a liquidation, dissolution or winding-up of the Issuer or the appointment of a receiver or administrator or analogous person under any applicable law in respect of the whole or substantially the whole of the Issuer's Assets, the Structured Warrants remaining outstanding shall be deemed to be exercised on the Market Day immediately prior to the date of such liquidation, dissolution, winding-up or appointment as follows:
- (a) All unexercised Structured Warrants shall be automatically exercised without the Holders having to deliver a valid Exercise Form and without notice of automatic exercise being given by the Issuer to the Holders:
 - (i) if the Cash Settlement Amount after deduction of the Exercise Expenses, if any, is greater than zero, the Issuer shall make payment of the Cash Settlement Amount to the relevant Holder; or

ANNEXURE I PRINCIPAL TERMS OF THE DEED POLL (cont'd)

- (ii) if the Cash Settlement Amount after deduction of the Exercise Expenses, if any, is equal to or less than zero, the Issuer shall not be obliged to make any payment to the relevant Holder and the relevant Structured Warrants shall terminate and cease to be valid and the Issuer's obligations in respect of the Structured Warrants shall terminate absolutely. For the avoidance of doubt, the Holder shall not be required to pay or top-up the Exercise Expenses, if any, as the case may be, where the Cash Settlement Amount after deduction of the Exercise Expenses, if any, is less than zero.

The closing price of the Underlying ETF on the Market Day immediately before the above events shall form the Closing Price for the calculation of the Cash Settlement Amount.

- (b) Notwithstanding the foregoing, if there is a Market Disruption Event on the Set Date, the Closing Price shall be based on the Market Day immediately preceding the Market Disruption Event. If the preceding Market Day is also affected by the Market Disruption Event, the Closing Price shall be determined by the Issuer on the Set Date as it reasonably deems fit and on the basis of the Issuer's good faith estimate the reference price and/or the exchange rate (if applicable) for that Set Date by determining the price of the Underlying ETF and/or the exchange rate (if applicable) based on the prevailing market conditions and other factors as the Issuer may consider relevant.

12 Replacement of Structured Warrant Certificate

- 12.1 If the Structured Warrant Certificate which has been deposited with Bursa Depository is mutilated, defaced, lost, worn out, stolen or destroyed it shall be replaced by the Issuer at the registered office of the Structured Warrants Registrar on such terms as to evidence and indemnity or otherwise as the Issuer may require. All payment of such costs as may be incurred in connection therewith shall be borne by the Issuer. Mutilated, defaced, lost, worn, stolen or destroyed Structured Warrant Certificates shall be deemed cancelled.

13 Register, Transfer and Transmission

- 13.1 Each Holder registered in the Record of Depositors shall be entitled to all rights, benefits, powers and privileges and be subject to all liabilities, duties and obligations in respect of, or arising from the Structured Warrants, and shall be deemed and treated as the absolute owner of the relevant Structured Warrants, in accordance with the Central Depositories Act and the Rules of Bursa Depository, whether or not the Issuer shall be in default in respect of the Structured Warrants or any of the covenants contained herein and notwithstanding any notice of ownership or writing thereon or notice of any previous loss or theft of any Structured Warrants. The provisions of the Central Depositories Act, the Rules of Bursa Depository and the Issuer's constitution for the time being relating to the registration, transfer and transmission of shares and the fees payable thereon shall with necessary modifications apply to the registration, transfer and transmission of the legal ownership of the Structured Warrants, subject always to the provisions of this Condition 13 and Condition 2.
- 13.1 The entries made under the Record of Depositors shall be deemed to be the final record of all Depositors. No notice of any trust, express or implied, shall be entered upon the Record of Depositors otherwise than pursuant to an order of a court of competent jurisdiction or as required by law, and a Holder shall be deemed to be the beneficial owner of the Structured Warrants standing to the credit of his/its Securities Account, until such time as the Structured Warrants are duly transferred to another Holder and the name of the transferee is entered in the Record of Depositors.

14 Meetings of Holders

- 14.1 The procedure governing the convening and conduct of meetings of the Holders are set out in the Fourth Schedule to the Deed Poll.

ANNEXURE I **PRINCIPAL TERMS OF THE DEED POLL** *(cont'd)***15** **Notices**

15.1 Subject to Condition 15.2:

- (a) all notices to the Holders pertaining to the convening of meetings shall be made by way of notice published in at least one (1) English language national daily newspaper and announced through Bursa Securities; and
- (b) all other notices shall either be announced through the Bursa Securities or published in at least one (1) English language national daily newspaper.

15.5 A notice is deemed to have been given and served to the Holders on the date of announcement or publication as the case may be or, if announced or published more than once or on different dates, on the first date on which it is announced or published.

15.6 All notices effected in accordance with this Condition 15 shall be deemed to be effective in respect of all persons who become Holders after the date of the relevant notice.

15.7 For the avoidance of doubt, a notice shall not be required to be published or announced in respect of an event contemplated under Conditions 6, 8, 9, 10 or 11, as the case may be, if no adjustment to the rights of the Holders or amendment to the terms and conditions of the relevant Structured Warrants is made or to be made pursuant thereto.

16 **Modification of rights**

16.1 All or any of the rights for the time being attached to the Structured Warrants (other than the Exercise Price which a Holder is entitled to or the formulae for the adjustment of the Exercise Price or the Exercise Ratio or any other condition, which may be modified in accordance with the provisions set out elsewhere in these Conditions) may be altered or abrogated by the Issuer from time to time (whether or not the Issuer is being wound up), and the sanction of a Special Resolution passed at a meeting of the Holders held as aforesaid shall be necessary to effect such alteration or abrogation.

16.2 Notwithstanding Condition 16.1, the Issuer may without the consent of the Holders but in accordance with the terms of the Deed Poll, effect any modification to the Structured Warrants or the Deed Poll which, in the opinion of the Issuer, is:

- (a) not materially prejudicial to the interests of the Holders; or
- (b) of a formal, minor or technical nature; or
- (c) necessary or expedient to correct a manifest error, or to comply with mandatory provisions of law; or
- (d) necessary or expedient to facilitate scripless trading in or exercise of the Structured Warrants or payment by way of electronic funds transfer as approved by the relevant government or statutory authorities in respect of the Structured Warrants or to amend the restrictions on transfer or exercise of the Structured Warrants to comply with the requirements of or the concessions granted by any relevant government or statutory authorities.

Any such modification shall be binding on all Holders and shall be notified by the Issuer to them as soon as practicable thereafter in accordance with Condition 15 but in any event not later than twenty (20) Market Days from the date of such modification.

16.3 Notwithstanding Condition 16.1, the Issuer may, at any time and from time to time for the purpose of an issue of new Structured Warrants or a new Series of Structured Warrants through the Base Prospectus and without the consent or sanction of the Holders supplement the Deed Poll with the terms and conditions of the new Structured Warrants or Series of Structured Warrants (as set out in the relevant Term Sheet), as the case may be. In the event such supplement to the Deed Poll shall affect the rights and interests of the Holders, the Issuer is to effect such supplement to the Deed Poll by notice to the Holders in accordance with Condition 15 and such supplement shall be binding on all Holders without any further action being required to be taken by the Issuer. For the avoidance of doubt, a Holder is deemed to have notice of all announcements (and their respective contents) made by the Issuer to Bursa Securities in respect of or affecting the Series of Structured Warrants held.

ANNEXURE I **PRINCIPAL TERMS OF THE DEED POLL** *(cont'd)***17** **Warrant Agency Agreement**

- 17.1 The Structured Warrants Registrar acts as an agent of the Issuer and shall not assume any obligation or duty to or any relationship of agency or trust for the Holders except only as described in Condition 17.2.
- 17.2 The Warrant Agency Agreement contains provisions for the indemnification of the Structured Warrants Registrar. The Structured Warrants Registrar shall not be liable to any Holder in respect of any losses, liabilities, costs, claims, actions or demands which such Holder may suffer or incur or allege to have suffered or incurred as a result of or in connection with the exercise or non-exercise of any Structured Warrants Registrar's powers, discretions and/or duties. The Structured Warrants Registrar may:
- (a) in the exercise of its powers, discretions and/or duties, act on the advice or opinion of, or any certificate or information obtained in good faith from, any lawyer, valuer, accountant, banker, broker, securities company or other expert whether obtained by the Issuer, the relevant Structured Warrants Registrar or otherwise (which advice, opinion, certificate or information may be sent or obtained by letter, email, telex, telegram, cable or facsimile device) and the Structured Warrants Registrar shall not be liable for any loss occasioned by acting in good faith on any such advice, opinion, certificate or information unless there are reasonable grounds for concluding that the same may be forged or otherwise not authentic or containing some errors with respect to content, delivery or transmission;
 - (b) receive and retain without liability to account, such fee or other remuneration as may from time to time be agreed between the Issuer and the Structured Warrants Registrar; and
 - (c) enter into or be interested in any contract or financial or other transaction or arrangement with the Issuer or any person or body corporate associated with the Issuer in connection therewith to receive and retain, without liability to account any profit, fee, remuneration or other benefit received thereby or in connection therewith.

The Structured Warrants Registrar does not act as the agent of any Holder and therefore owes no fiduciary duty to any Holder in arriving at its calculations and determinations.

18 **Exclusion of equities**

- 18.1 Subject to the Central Depositories Act, the Rules of Bursa Depository, the Deed Poll, or these Conditions, no person shall be recognised by the Issuer as holding any Structured Warrants upon any trust, and the Issuer shall not be bound by or compelled in any way to recognise any equitable, contingent, future or partial interest in any Structured Warrant, or any interest in any fractional part of a Structured Warrant, or (except only as by these presents or by law otherwise provided) any other right in respect of any Structured Warrants, except an absolute right to the entirety thereof in the registered holder.

19 **Force Majeure**

- 19.1 If the Issuer determines that, for reasons beyond the Issuer's control, the performance of the Issuer's obligations under the Structured Warrants has become illegal or impractical in whole or in part for any reason, or the Issuer determines that, for reasons beyond the Issuer's control, it is no longer legal or practical for the Issuer to maintain the Issuer's hedging arrangements with respect to the Structured Warrants for any reason, the Issuer may in the Issuer's discretion and without obligation terminate the Structured Warrants early by giving notice to the Holders in accordance with Condition 15.

20 **Governing law**

- 20.1 The Structured Warrants and the Deed Poll are governed by and shall be construed in accordance with the laws of Malaysia. The Issuer and the Holders irrevocably agree that with respect to any proceedings in Malaysia in connection with any matter or issue relating to the Deed Poll and these Conditions, they shall be bound by the decision, ruling or order of the Malaysian Court.

PART 7

CONDITIONS OF THE BULL EQUITY-LINKED STRUCTURE

1 General, Nature, Form, Transfer, Administration and Status of Structured Warrants

- 1.1 The Structured Warrants comprise of **bull equity-linked structures** to be issued from time to time by the Issuer through the Base Prospectus and subject to, and with the benefit of the Deed Poll referred to on the face of the Structured Warrant Certificate and these Conditions. The Exercise Rights entitle the Holder of each Structured Warrant for each Series of Structured Warrants issued or to be issued, subject to the Deed Poll and in accordance with these Conditions, upon valid exercise thereof, to the Physical Settlement Amount (or its cash equivalent), Cash Settlement Amount for Odd Lots and/or Cash Settlement Amount, as the case may be, calculated in accordance with Condition 2. Certain statements in these Conditions are summaries of and are subject to the detailed provisions of the Deed Poll and in the event of any inconsistency between a provision contained in these Conditions and a provision contained in the Deed Poll, the provisions in the Deed Poll shall prevail. Copies of the Deed Poll and the Warrant Agency Agreement are available for inspection at the registered office of the Issuer, being at the date hereof at 22nd Floor, Bangunan AmBank Group, No. 55 Jalan Raja Chulan, 50200 Kuala Lumpur, Malaysia. The Holders for the time being of the Structured Warrants and whose names appear on the Record of Depositors are all entitled to the benefit of, bound by, and deemed to have notice of, all the provisions of the Deed Poll. Further, each Holder acknowledges it has, where necessary, consulted its stockbroker, solicitor or other adviser before investing in the Structured Warrants and none of the Issuer or its directors or employees may be construed as investment adviser or agent of, or owe any fiduciary duty to the Holder. **For the purposes of this Part 7, the term “Structured Warrants” shall refer to the bull equity-linked structures.**
- 1.2 Subject to the Central Depositories Act, the Rules of Bursa Depository, the Deed Poll, the relevant applicable rules and regulations and these Conditions:
- (a) each Structured Warrant requires the Issuer to make or pay the Physical Settlement Amount (or its cash equivalent), Cash Settlement Amount for Odd Lots and/or Cash Settlement Amount, as the case may be, to the Holder in accordance with these Conditions; and
 - (b) the Structured Warrants are issued in registered form, serially numbered and are a Prescribed Security to be admitted to the Official List. The Structured Warrants are represented by a global/jumbo certificate issued to Bursa Depository or its nominee who holds the same as bare trustee on behalf of the Holders, and deposited with Bursa Depository in or substantially in the form set out in the First Schedule to the Deed Poll as the same may from time to time be modified in accordance with the Deed Poll.
- 1.3 Subject to all information provided by the subscriber for the Structured Warrants to the Issuer being complete and consistent with the records of Bursa Depository, the Issuer shall within seven (7) Market Days from the date of allotment of the Structured Warrants, cause and procure the Structured Warrants Registrar to notify Bursa Depository of the names of the Holders together with such particulars as may be required by Bursa Depository for the purpose of making appropriate entries in the Securities Account of the respective Holder, request Bursa Depository to credit the Securities Account of the Holders with the applicable Structured Warrants and shall deliver to Bursa Depository the Structured Warrant Certificate registered in the name of Bursa Depository or its nominee company in such manner as may be prescribed by the Rules of Bursa Depository or agreed with Bursa Depository. If, at any time, the information provided by the Holders for the Structured Warrants is incorrect or inaccurate or inconsistent with the records of Bursa Depository, the Issuer reserves the right and without any obligation whatsoever, to accept, reject or otherwise deal with the Structured Warrants in such manner as it reasonably deems fit in the circumstances. The Holders are not entitled to any physical warrant certificates.
- 1.4 Subject to the provisions of the Central Depositories Act and the Rules of Bursa Depository, the registration and subsequent administration of Structured Warrants shall be in the manner set forth in the Deed Poll. It is hereby acknowledged that the Issuer shall be entitled to appoint registrars for the registration and administration of the Structured Warrants. The Issuer hereby confirms that it

ANNEXURE I PRINCIPAL TERMS OF THE DEED POLL (cont'd)

shall/has appointed the Structured Warrants Registrar for the purpose stipulated hereof, who shall perform such duties as required by the Issuer under the Deed Poll.

- 1.5 The Holders may transfer the Structured Warrants in the manner prescribed under the Central Depositories Act and the Rules of Bursa Depository. Subject to the provisions of the Central Depositories Act and the Rules of Bursa Depository, the Structured Warrants shall be freely transferable but the trading of the Structured Warrants must be in the same board lot applicable to the trading of the Underlying Equity or in such odd lots as permitted by the SC and/or Bursa Securities. Where the board lot of the Underlying Equity is more than hundred (100) equities per board lot, the Structured Warrants may be issued in board lots of hundred (100) warrants.
- 1.6 The Structured Warrants and the settlement obligation of the Issuer in respect of the Structured Warrants represent general and unsecured contractual obligations of the Issuer and of no other person which rank, and shall rank, equally among themselves and without preference in all respects, subject to such exceptions as may from time to time exist under applicable law or the Deed Poll, with the other existing and future unsecured and subordinated obligations of the Issuer.
- 1.7 The Holders are entitled to the Physical Settlement Amount (or its cash equivalent), Cash Settlement Amount for Odd Lots (if any) of the Cash Settlement Amount, as the case may be, in accordance with Condition 2 provided always that the settlement to the Holder must be in cash if the Underlying Equity comprise of equities quoted on a Securities Exchange outside Malaysia.

2 Exercise of the Structured Warrants

2.1 Exercise Rights

2.1.1 The Structured Warrants shall be automatically exercised at 5.00 p.m. on the Expiry Date (without the Holders having to deliver a valid Exercise Form and without notice of automatic exercise being given by the Issuer to the Holders) and the Issuer shall pay the Cash Settlement Amount or deliver the Physical Settlement Amount (or its cash equivalent), as the case may be, to the Holder in accordance with this Condition 2.1. If the Expiry Date is not a Market Day then the Structured Warrants are deemed to be exercised on the next following Market Day.

2.1.2 The Issuer shall in the absence of a Settlement Disruption Event, within seven (7) Market Days from the Expiry Date or such other period as may be prescribed by Bursa Securities or such other relevant authority, pay to the relevant Holder, the Cash Settlement Amount or deliver the Physical Settlement Amount (or its cash equivalent) set out below less all Exercise Expenses incurred in respect of the exercise of the Structured Warrants:

- (a) if the Closing Price⁽¹⁾ of the Underlying Equity is equal to or exceeds the Exercise Price⁽²⁾, the Holder shall be entitled to the Cash Settlement Amount in the Settlement Currency calculated as set out below, less all Exercise Expenses:

$$\text{Cash Settlement Amount} = (\text{Number of Structured Warrants held} \times \frac{1}{\text{Exercise Ratio}}) \times \text{Settlement Exchange Rate (if applicable)}$$

- (b) if the Closing Price of the Underlying Equity is below the Exercise Price, the Holder shall be entitled to the Physical Settlement Amount which shall be the number of Underlying Equity equivalent to the number of units of Structured Warrants held on the Expiry Date divided by the Exercise Ratio, or, the cash equivalent of the Physical Settlement Amount (if the Underlying Equity comprise of equities quoted on a Securities Exchange outside Malaysia) as determined by the Issuer as it reasonably deems fit.

For the avoidance of doubt, if a book closure date has been declared by the Underlying Company and trading in the Underlying Equity is on a “cum-entitlement” basis on the Expiry Date, the Underlying Equity to be delivered by the Issuer to the Holder upon the valid exercise of the Structured Warrants shall also be on a “cum-entitlement” basis.

ANNEXURE I

PRINCIPAL TERMS OF THE DEED POLL (cont'd)

- (1) (a) The Closing Price on the Expiry Date shall be calculated by reference to either:
- (i) the average VWAP of the Underlying Equity (subject to any adjustment as may be necessary to reflect any capitalisation, rights issue, distribution or others) for the five (5) Market Days prior to and including the Market Day immediately before the Expiry Date;
 - (ii) the average closing price of the Underlying Equity (subject to any adjustment as may be necessary to reflect any capitalisation, rights issue, distribution or others) for the five (5) Market Days prior to and including the Market Day immediately before the Expiry Date; or
 - (iii) the closing price of the Underlying Equity on the Market Day immediately before the Expiry Date,

and as specified in the relevant Term Sheet and subject to the Market Disruption Event and other provisions herein.

If the Expiry Date falls within the Take Over Offer Period or the Compulsory Acquisition Period, the Closing Price shall be as calculated above or the announced price for the Take-over Offer, whichever is lower.

If the Expiry Date falls on a Market Day when the Underlying Equity is suspended from trading as a result of the Take-over Offer or the Compulsory Acquisition, the Closing Price shall be the last quoted price of such Underlying Equity immediately before the suspension (subject to the Market Disruption Event provision below), or the announced price for the Take-over Offer, whichever is lower.

For the avoidance of doubt, in the event any of the Underlying Equity is delisted, the Closing Price shall be determined in accordance with Condition 10 below.

- (b) If a Market Disruption Event, or a public holiday unexpected by the Issuer, occurs on any of the five (5) Market Days described in sub-Conditions (1)(a)(i) or (1)(a)(ii) above, the valuation period applicable and the Closing Price shall be as determined by the Issuer as it reasonably deems fit.

In any other cases where there is a single Valuation Date, if there is a Market Disruption Event on the Valuation Date, the Valuation Date shall be the next following Market Day after the Market Disruption Event. If the Market Disruption Event continues to occur up to the eighth (8th) Business Day following the original Valuation Date, then the Valuation Date shall be:

- (i) that eighth (8th) Business Day; and
- (ii) the Issuer shall determine as it reasonably deems fit and on the basis of the Issuer's good faith estimate the reference price and/or the exchange rate (if applicable) for that Valuation Date by determining the price of the Underlying Equity and/or the exchange rate (if applicable) based on the prevailing market conditions and other factors as the Issuer may consider relevant.

- (2) The Exercise Price and/or Exercise Ratio shall be subject to such adjustments as may be necessary as provided in Condition 6.

- 2.1.3 The Issuer shall in the absence of a Settlement Disruption Event, deliver the Physical Settlement Amount (where applicable) comprising the relevant Underlying Equity to the exercising Holder by crediting the relevant number of Underlying Equity which is equivalent to the number of the Structured Warrants held by the exercising Holder to the exercising Holder's Securities Account and despatch the notice of transfer to the Holder within seven (7) Market Days from the Expiry Date or such other period as may be prescribed by Bursa Securities or such other relevant authority. Provided always that the delivery of the

ANNEXURE I **PRINCIPAL TERMS OF THE DEED POLL** (cont'd)

Underlying Equity shall not be effected until the Exercise Expenses have been received by the Issuer or the Issuer is satisfied that the Exercise Expenses are received or shall be received by the Issuer from the Holder.

- 2.1.4 In the event the Holder is entitled to receive odd lots of the Underlying Equity upon valid exercise of the Structured Warrants, the Issuer shall pay to the relevant Holder, in respect of such odd lots of the Underlying Equity, the Cash Settlement Amount for Odd Lots less all Exercise Expenses, if any, in the absence of a Settlement Disruption Event, within seven (7) Market Days from the Exercise Date or such other period as may be prescribed by Bursa Securities or such other relevant authority. The Cash Settlement Amount for Odd Lots less Exercise Expenses, if any, is calculated as follows:

$$\text{Cash Settlement Amount for Odd Lots} = \text{Number of Underlying Equity in odd lots} \times \text{Closing Price}$$

- 2.1.5 The Cash Settlement Amount or Cash Settlement Amount for Odd Lots, less the Exercise Expenses may be made by way of cheque drawn in favour of the Holder to be delivered by ordinary post to the Holder's address last recorded in the Record of Depositors at the Holder's own risk or by way of electronic transfer of funds to the bank account of the Holder, the details of which are provided by Bursa Depository to the Issuer at the request of the Issuer. Where the Issuer makes a payment to a Holder pursuant to the terms of this Condition 2.1, the amount of such payment arising from the exercise of the Structured Warrants shall be final and conclusive and the Issuer shall be discharged from its obligations upon making such payment thereof in accordance with these conditions.
- 2.1.6 The Cash Settlement Amount less the Exercise Expenses shall be calculated and be payable in Settlement Currency and rounded down to the nearest two (2) decimal points. All determinations made by the Issuer pursuant to this Condition 2.1.6 (in the absence of manifest error) shall be final and conclusive and binding on the Holders.
- 2.1.7 In the event the Issuer is unable to deliver the Underlying Equity upon the automatic exercise of the Structured Warrants, the Issuer shall pay the Holders the Cash Settlement Amount in the Settlement Currency, which shall be calculated in accordance with Condition 2.1.10 below, less all Exercise Expenses. The events that would result in the Issuer unable to deliver the Underlying Equity are liquidation, dissolution or winding-up of the Underlying Company or the Underlying Equity is suspended or have been delisted on the Expiry Date. Upon occurrence of any of these events, the Issuer will make the necessary announcement prior to the Expiry Date, that the Structured Warrants shall be cash-settled.
- 2.1.8 The Holder is to bear all Exercise Expenses in relation to the exercise of the Structured Warrants and on exercise of the Structured Warrants, the Issuer shall be irrevocably authorised by the Holder to deduct all Exercise Expenses from the Cash Settlement Amount.
- 2.1.9 If as a result of a Settlement Disruption Event, it is not possible for the Issuer to make payment on the original Settlement Date, the Issuer shall use its reasonable endeavours to procure payment as soon as practicable after the original Settlement Date. The Issuer shall not be liable to the Holder for any interest in respect of the amount due or any loss or damage that such Holder may suffer as a result of the existence of the Settlement Disruption Event.
- 2.1.10 Notwithstanding the above, in the case where the Underlying Equity are equities quoted on a Securities Exchange outside Malaysia, the Holder shall only be entitled to Cash Settlement Amount which shall be calculated in the manner set out below less all Exercise Expenses:

- (a) if the Closing Price⁽¹⁾ of the Underlying Equity is equal to or exceeds the Exercise Price⁽²⁾, the Holder shall be entitled to Cash Settlement Amount payable in the Settlement Currency calculated as set out below less all Exercise Expenses:

$$\text{Cash Settlement Amount} = \frac{\text{(Number of Structured Warrants held} \times \text{Exercise Price)}}{\text{Exercise Ratio}} \times \text{Settlement Exchange Rate (if applicable)}$$

ANNEXURE I **PRINCIPAL TERMS OF THE DEED POLL** (cont'd)

- (b) If the Closing Price of the Underlying Equity is below the Exercise Price, the Holder shall be entitled to Cash Settlement Amount payable in the Settlement Currency calculated as set out below:

$$\text{Cash Settlement Amount} = (\text{Number of Structured Warrants held} \times \text{Closing Price}) \times \frac{1}{\text{Exercise Ratio}} \times \text{Settlement Exchange Rate (if applicable)}$$

- 2.2 The Issuer shall not allow the Holder to exercise the Exercise Rights unless the Structured Warrants are or have been designated as “free securities” in accordance with the Rules of Bursa Depository.
- 2.3 The Issuer declares that approval shall be sought from Bursa Securities for the admission of the Structured Warrants to the Official List and for the listing of and quotation for the Structured Warrants on Bursa Securities.
- 2.4 All questions as to the validity, form, eligibility (including time of receipt) and acceptance of Exercise Form shall be resolved by the Structured Warrants Registrar in its sole discretion, whose determination shall be final and binding on the Issuer and the Holder. The Structured Warrants Registrar reserves the absolute right to reject any Exercise Form that is not in proper form or the acceptance of which may, in the view of counsel for the Structured Warrants Registrar be unlawful. The Structured Warrants Registrar also reserves the absolute right, subject to applicable law, to waive any irregularities. The interpretation of the Structured Warrants Registrar of the terms and conditions of exercise of the Structured Warrants shall be final and binding on the Issuer and the Holder. Unless waived, any irregularities in connection with the Exercise Form must be rectified by such time, as the Structured Warrants Registrar shall determine. The Structured Warrants Registrar shall not be under any duty to give notification of any irregularities in such Exercise Form and shall not incur liabilities for failure to give such notification. The Exercise Form shall not be considered to have been validly delivered until such irregularities have been rectified and waived.
- 2.5 The initial Structured Warrants Registrar and its specified offices are stated in the Deed Poll. The Issuer reserves the right at any time to vary or terminate the appointment of the Structured Warrants Registrar. Prior written notice of any termination, appointment of Structured Warrants Registrar, resignation of the Structured Warrants Registrar or any changes in any of the specified offices of the relevant Structured Warrants Registrar shall be given to the Holders in accordance with Condition 15 and such prior notice shall be given to the Holders not more than sixty (60) days and less than thirty (30) days of such termination, appointment, resignation or change.
- 2.6 In respect of each exercised Structured Warrant, the Issuer shall instruct or procure the Structured Warrants Registrar to instruct Bursa Depository, in accordance with the Central Depositories Act and the Rules of Bursa Depository, to debit the Structured Warrant from the Securities Account of the Holder. The Issuer shall be entitled at any time on or after the Expiry Date, to demand that Bursa Depository deliver to the Issuer the Structured Warrant Certificates and thereafter cancel or cause the cancellation of the Structured Warrant Certificates.
- 2.7 The Structured Warrants subject to the Exercise Rights which have been exercised in accordance with the Deed Poll shall cease to exist and all obligations of the Issuer in respect of those Structured Warrants shall terminate absolutely following payment of the amount (if any) referred to in this Condition 2.

3 Exercise Rights and Suspension

- 3.1 Upon and subject to the provisions of the Central Depositories Act, the Rules of Bursa Depository and the Deed Poll, the Holder whose name as stated in the Record of Depositors shall have the right at any time during the Exercise Period to invoke its Exercise Rights at the Exercise Price subject to adjustments in accordance with Condition 6.
- 3.2 The Structured Warrants shall, subject to any directions, order or notice from any relevant regulatory authority and any request for suspension by the Issuer which is not rejected by any such relevant regulatory authority, continue to be traded notwithstanding that the trading of the Underlying Equity of the Underlying Company, may have been suspended. Any suspension in the trading of the

ANNEXURE I **PRINCIPAL TERMS OF THE DEED POLL** *(cont'd)*

Underlying Equities or the Structured Warrants shall not preclude the Holder from exercising the Exercise Rights.

- 3.3 The Issuer shall notify the Holders of the Expiry Date at least two (2) weeks prior to the Expiry Date for Structured Warrants with a tenure of twenty eight (28) days but not more than six (6) months and at least one (1) month prior to the Expiry Date for Structured Warrants with more than six (6) months' tenure or such other period as may be specified by the relevant authority. Such notice shall be given in accordance with Condition 15 stating the Expiry Date and treatment of the Structured Warrants which are not exercised.

4 **Deposit and Forfeiture of Unclaimed Amount**

- 4.1 In the event that the Issuer pays the Cash Settlement Amount for Odd Lots or Cash Settlement Amount, as the case may be, to any Holder under Condition 2 and such Holder does not present the cheque for payment within six (6) months from the date of the cheque, the Issuer shall at any time thereafter deal with the said monies in accordance and in compliance with, the requirements of the Unclaimed Moneys Act 1965 (Act 370) (revised 1989) of Malaysia.

5 **Designation of Structured Warrants set out in the Exercise Form**

- 5.1 Subject to the approval of Bursa Depository and/or other relevant authority, the Issuer reserves all rights to instruct Bursa Depository and/or other relevant authority to designate the Structured Warrants held in the relevant Securities Account of a Holder which the Holder has purportedly exercised by submitting an Exercise Form to the Issuer and/or the Structured Warrants Registrar, in order for Bursa Depository and/or the relevant authority to prohibit the Holder from trading on the exchange the designated Structured Warrants after the aforesaid exercise. The Issuer's right to instruct Bursa Depository and/or the relevant authority shall be independent of whether the exercise is valid or otherwise, provided that the amount of Structured Warrants so designated by Bursa Depository and/or the relevant authority do not exceed the amount set out in such Exercise Form.

6 **Adjustment of Exercise Price**

- 6.1 Adjustments

Subject to the Conditions as hereinafter provided and the Deed Poll, the Exercise Price for the relevant Structured Warrant shall from time to time be adjusted in accordance with the following provisions:

- (a) Bonus Issue

If and whenever the Underlying Company of the relevant Structured Warrants shall make an issue of new equities ("**Equities**") credited as fully paid-up to the holders of Equities generally by way of capitalisation of profits or reserves (other than pursuant to a scrip dividend or similar scheme for the time being operated by the relevant Underlying Company or otherwise in lieu of a cash dividend and without any payment or other consideration being made or given by such holders) ("**Bonus Issue**"), the Exercise Price shall be adjusted on the Market Day immediately following the last day on which an instrument of transfer could be lodged so that the transferee of the Equities would qualify for the Bonus Issue in accordance with the following formula:

- (i) Adjusted Exercise Ratio =
$$\frac{E}{(1 + N)}$$
- (ii) Adjusted Exercise Price =
$$\frac{X}{(1 + N)}$$

Whereby in respect of this Condition 6.1(a)(i) and (ii):

ANNEXURE I **PRINCIPAL TERMS OF THE DEED POLL** (*cont'd*)

- X = Existing Exercise Price immediately prior to the Bonus Issue
- N = The number of additional Equities (whether a whole or a fraction) received by a holder of existing Equities for each Equity (of the relevant Underlying Company) held prior to the Bonus Issue
- E = Existing Exercise Ratio immediately prior to the Bonus Issue

Alternatively, the Issuer may also, in good faith, make a corresponding adjustment to the Exercise Price as the Issuer determines appropriate to account for the dilutive effect of the Bonus Issue.

On any such adjustment, the resultant Exercise Price shall be rounded down to the nearest two (2) decimal points and all such adjustment made by the Issuer pursuant to this Condition shall be deemed as final and conclusive save for any manifest error.

(b) Rights Issue

If and whenever an Underlying Company of the relevant Structured Warrants shall, by way of Rights (as defined below), offer new Equities for subscription at a fixed subscription price ("**Rights Issue Price**") to the holders of existing Equities pro rata to existing holdings ("**Rights Issue**"), the Exercise Price shall be adjusted on the Market Day immediately following the last day on which an instrument of transfer of such Equities could be lodged so that the transferee of the Equity(ies) would qualify for the Rights Issue in accordance with the following formula:

(i) Adjusted Exercise Ratio =

$$\frac{1 + (R/S) \times M}{1 + M} \times E$$

(ii) Adjusted Exercise Price =

$$\frac{1 + (R/S) \times M}{1 + M} \times X$$

Whereby, in respect of this Condition 6.1(b)(i) and (ii):

- R = Subscription price per Equity of the Underlying Company of the relevant Structured Warrants under the Rights Issue.
- S = Cum-rights share price being the last traded price of an existing Equity of the Underlying Company of the relevant Structured Warrants making the Rights Issue on the last Market Day on which the Equities (of the Underlying Company of the relevant Structured Warrants making the Rights Issue) are traded on a cum-rights basis.
- M = Number of new Equities (whether a whole or fraction) per existing equity of the Underlying Company of the relevant Structured Warrants making the Rights Issue each holder thereof is entitled to subscribe.
- X = Existing Exercise Price immediately prior to the Rights Issue.
- E = Existing Exercise Ratio immediately prior to the Rights Issue.

Alternatively, the Issuer may also, in good faith, make a corresponding adjustment to the Exercise Price as the Issuer determines appropriate to account for the dilutive effect of the Rights Issue.

ANNEXURE I**PRINCIPAL TERMS OF THE DEED POLL** (cont'd)

On any such adjustment, the resultant Exercise Price shall be rounded to the nearest four (4) decimal points of the Relevant Currency and all such adjustment made by the Issuer pursuant to this Condition shall be deemed as final and conclusive save for any manifest error.

For the purposes hereof, "**Rights**" means the Right(s) attached to each existing Equity or needed to acquire one new Equity (as the case may be) which are given to the holders of existing Equities to subscribe at a fixed subscription price for new Equities pursuant to the Rights Issue (whether by the exercise of one Right, a part of a Right or an aggregate number of Rights).

(c) Subdivision or Consolidation

If and whenever the Underlying Company of the relevant Structured Warrants shall subdivide its Equities or any class of its outstanding share capital comprising the Equities into a greater number of Equities (a "**Subdivision**"), or consolidate the equities or any class of its outstanding share capital comprising the equities into a smaller number of equities (a "**Consolidation**"), the Exercise Price shall be adjusted on the Market Day on which the relevant Subdivision or Consolidation shall have taken effect in accordance with the following formula:

$$(i) \quad \text{Adjusted Exercise Ratio} = \frac{E \times P}{N}$$

$$(ii) \quad \text{Adjusted Exercise Price} = \frac{X \times P}{N}$$

Whereby, in respect of this Condition 6.1(c)(i) and (ii):

X = Existing Exercise Price immediately prior to the Subdivision or Consolidation.

N = Revised number of issued shares after the Subdivision or Consolidation.

P = Existing number of issued shares immediately prior to the Subdivision or Consolidation.

E = Existing Exercise Ratio immediately prior to the Subdivision or Consolidation.

Alternatively, the Issuer may also, in good faith, make a corresponding adjustment to the Exercise Price as the Issuer determines appropriate to account for the dilutive or consolidative effect of the Subdivision or Consolidation.

On any such adjustment, the resultant Exercise Price shall be rounded to the nearest four (4) decimal points of the Relevant Currency and all such adjustment made by the Issuer pursuant to this Condition shall be deemed as final and conclusive save for any manifest error.

(d) Capital Repayment

Should the Underlying Company of the relevant Structured Warrants undertake a capital repayment in cash whether in the form of special dividend or not (pursuant to Section 115 of the Companies Act 2016 or such other corresponding provision in the Relevant Country in which the Underlying Equity is listed and quoted) during the tenure of the Structured Warrants, the Exercise Price of the Structured Warrants shall be adjusted on the Market Day following the last day on which an instrument of transfer is lodged to enable the transferee of the

ANNEXURE I **PRINCIPAL TERMS OF THE DEED POLL** *(cont'd)*

Equities to qualify for the capital repayment by the amount of the capital repayment, net of taxation, if any.

The Exercise Price for the Structured Warrants shall be adjusted in accordance with the following formula:

(i) Adjusted Exercise Ratio =

$$E \times \frac{(P - D)}{P}$$

(ii) Adjusted Exercise Price =

$$X \times \frac{(P - D)}{P}$$

Whereby, in respect of this Condition 6.1(d)(i) and (ii):

P = Closing price of the Underlying Equity immediately preceding the last market day on which the Underlying Equity is traded on a cum-entitlement basis.

D = The capital repayment/special dividend per one (1) Underlying Equity held.

X = Existing Exercise Price immediately prior to the capital repayment/special dividend.

E = Existing Exercise Ratio immediately prior to the capital repayment.

The Exercise Ratio and/or Exercise Price of the Structured Warrants shall not be adjusted for capital repayment in specie or in the form of other securities, other than for bonus issue and rights issue pursuant to Conditions 6.1(a) and (b).

Alternatively, the Issuer may also in good faith make a corresponding adjustment to the Exercise Price and/or Exercise Ratio as the Issuer determines appropriate to account for the effect of the capital repayment.

On any such adjustment, the resultant Exercise Price shall be rounded down to the nearest two (2) decimal points and all such adjustment made by the Issuer pursuant to this Condition shall be deemed as final and conclusive save for any manifest error.

Notwithstanding the above, if a capital repayment undertaken by the relevant Underlying Company results in a significant change in the business of such Underlying Company or such other circumstances as the Issuer may determine, the Issuer is entitled to terminate the Structured Warrants without prior notice to the Holders. If the Issuer terminates the Structured Warrants, then the Issuer will, if and to the extent permitted by applicable law, pay an amount to each Holder in respect of each Structured Warrant held by such Holder if the Cash Settlement Amount after deduction of the Exercise Expenses, if any, is greater than zero (without the Holder having to deliver a valid Exercise Form). The Cash Settlement Amount shall be determined by the Issuer in a manner as it reasonably deems fit based on the fair market value of the Structured Warrants (as determined by the Issuer) after taking into account the capital repayment exercise less all Exercise Expenses, if any.

(e) Other adjustments

The Issuer is entitled to make such adjustments as it reasonably believes are appropriate in circumstances where an event or events occur which the Issuer believes (notwithstanding any adjustment previously made by the Issuer) should, in the context of the issue of Structured Warrants and its obligations hereunder, give rise to such adjustment, provided that such adjustment is considered by the Issuer to be beneficial to Holders generally without

ANNEXURE I **PRINCIPAL TERMS OF THE DEED POLL** *(cont'd)*

considering the individual circumstances of any Holder or the tax or other consequences of such adjustment in any particular jurisdiction.

On any such adjustment, the resultant Exercise Price shall be rounded to the nearest four (4) decimal points of the Relevant Currency.

- 6.2 Notwithstanding the foregoing, no adjustments shall be made to the Exercise Price if the formulae stated in Condition 6.1(a) to Condition 6.1(e) results in an adjustment which would amount to less than two percent (2%) of the Exercise Price being changed.
- 6.3 Any termination of Structured Warrants or adjustment made pursuant to Conditions 6.1 and 6.2 shall be final and binding on the Holders save in the case of manifest error. Notice of such termination, adjustments or amendments shall be given to the Holders as soon as practicable thereafter in accordance with Condition 15 and in any event within five (5) Market Days of such termination or adjustment being made.

7 **Restrictions to Protect Rights of Holders**

- 7.1 As from the date of the issue of the Structured Warrants and for so long as any of the Structured Warrants remain exercisable, the Issuer shall have arrangements in place to ensure, for the benefit of the Holders that it is able to satisfy in full the exercise of all the Structured Warrants for the time being outstanding.

8 **Merger or Consolidation of Underlying Company**

- 8.1 In the event of a merger, amalgamation or reconstruction of the Underlying Company wherein an Underlying Company is to or may merge or consolidate with or into any other corporation (including becoming, by agreement or otherwise, a subsidiary of any corporation or controlled by any person or corporation) (except where the Underlying Company is the surviving corporation in a merger), or is to or may sell or transfer all or substantially all of its assets ("**Restructuring Event**"), the Issuer may in good faith take any of the actions below:
- (a) cancel the Structured Warrants without prior notice to the Holders. If the Structured Warrants are so cancelled, the Issuer shall pay an amount to each Holder, if the Cash Settlement Amount after deducting all Exercise Expenses, is greater than zero (without the Holder having to deliver a valid Exercise Form). The Cash Settlement Amount shall be determined by the Issuer in a manner as it reasonably deems fit based on the fair market value of the Underlying Equity (as determined by the Issuer) after taking into account the Restructuring Event less all Exercise Expenses; and/or
 - (b) amend and determine the appropriate adjustment, if any, to be made to the terms and conditions of the Structured Warrants to account for the Restructuring Event and determine the effective date of that adjustment. After such adjustments (if any), the Structured Warrants shall relate to the number of equities of the corporation(s) resulting from or surviving such Restructuring Event or other securities ("**Substituted Securities**") and/or cash offered in substitution for the affected Underlying Equity of the relevant Structured Warrants to which the holder of such number of Underlying Equity to which the Structured Warrants related immediately before such Restructuring Event would have been entitled upon such Restructuring Event, as the case may be. The Issuer may, but need not, determine the appropriate adjustment by reference to the adjustment in respect of the Restructuring Event made by a Securities Exchange to options on the relevant Underlying Equity traded on that Securities Exchange.
- 8.2 Upon the occurrence of a Restructuring Event, the rights attaching to the Structured Warrants in respect of that Underlying Company may be amended by the Issuer no later than the Market Day preceding the consummation of such Restructuring Event.
- 8.3 The provisions of these Conditions shall apply to such Substituted Securities provided that, any Substituted Securities may, as the Issuer reasonably deems fit, be replaced by an amount in the Relevant Currency equal to the market value or, if no market value is available, fair value, of such

ANNEXURE I **PRINCIPAL TERMS OF THE DEED POLL** *(cont'd)*

Substituted Securities in each case as determined by the Issuer as soon as practicable after such Restructuring Event is effected.

- 8.4 Any cancellation of Structured Warrants or modification of rights made pursuant to Condition 8.1 or 8.2 above shall be notified to the Holders as soon as practicable thereafter and in any event within five (5) Market Days from the date of such cancellation or modification in accordance with Condition 15.

9 Take-over Offer, Compulsory Acquisition or other Forms of Reorganisation in respect of the Underlying Company

9.1 Take-over Offer, Compulsory Acquisition

In the event of the Take-Over Offer or Compulsory Acquisition or any other event having similar effect on the rights of the Holders (“**Other Event**”) no cancellation of the relevant Structured Warrants shall be effected and the relevant Structured Warrants shall remain exercisable by the Holder for the remaining tenure of the Exercise Period unless any such Take-Over Offer, Compulsory Acquisition or Other Event results in any of the circumstances referred to in Condition 10 or Condition 11, in which event, the relevant provisions of Condition 10 or Condition 11 shall apply.

9.2 Other Forms of Reorganisation

In the event of a scheme of arrangement or any other forms of reorganisation including any scheme of arrangement or reorganisation resulting in the privatisation of the Underlying Company, or the Underlying Company is placed under a judicial management under any applicable laws, the Issuer is entitled to deal with the Structured Warrants in such manner as it reasonably deems fit in the circumstances and with or without any adjustments to the rights attaching to the relevant Structured Warrants.

10 Delisting of the Underlying Equity

- 10.1 If at any time the Underlying Equity of the Structured Warrants ceases to be listed on Bursa Securities or such other Securities Exchanges or there is an announcement of an intention to cease the listing status of the Underlying Company or the Underlying Equity is suspended from trading on Bursa Securities or such other Securities Exchanges prior to, and in connection with the delisting of the Underlying Equity, the Structured Warrants may if determined by the Issuer be automatically exercised without the Holder having to deliver a valid Exercise Form and without notice of automatic exercise being given by the Issuer to the Holder:

- (a) if the Cash Settlement Amount after deducting all Exercise Expenses is greater than zero, the Issuer shall make payment of the Cash Settlement Amount to the relevant Holder; or
- (b) if the Cash Settlement Amount after deducting all the Exercise Expenses is equal to or less than zero, the Issuer shall not be obliged to make any payment to the relevant Holder, and the relevant Structured Warrants shall lapse and cease to be valid and the Issuer’s obligations in respect of the Structured Warrants shall terminate absolutely. The Holders shall not be required to pay or top up the Exercise Expenses in the event the Cash Settlement Amount is negative after deducting Exercise Expenses.

In such event, the Closing Price for the calculation of the Cash Settlement Amount (calculated in accordance with Condition 2) shall be one of the following:

- (i) the last quoted price of the Underlying Equity immediately before such events;
- (ii) the price determined in accordance with Condition 2.1.2(1)(a);
- (iii) in the case of a Take-over Offer or a Compulsory Acquisition, the announced price for such Take-over Offer or Compulsory Acquisition,
- (iv) such other price as determined by the Issuer in a commercially reasonable manner,

as the case may be, and the Issuer shall not be obliged to make any adjustment to the Exercise Price.

ANNEXURE I **PRINCIPAL TERMS OF THE DEED POLL** *(cont'd)*

10.1 Subject to the aforesaid, the Issuer may but shall not be obliged to make any adjustment to the terms and conditions of the Structured Warrants and the rights attaching to the Structured Warrants as it shall reasonably consider appropriate to ensure that the interests of the Holders generally are not materially prejudiced as a consequence of such events (without considering the individual circumstances of any Holder or the tax or other consequences that may result in any particular jurisdiction).

11 Liquidation, Dissolution or Winding-Up of the Underlying Company

11.1 In the event of a liquidation, dissolution or winding-up of the Underlying Company or the appointment of a liquidator, receiver or administrator or analogous person under any applicable law in respect of the whole or substantially the whole of the Underlying Company's undertaking, property or assets, the Structured Warrants will be automatically exercised without the Holder having to deliver a valid Exercise Form and without notice of automatic exercise being given by the Issuer to the Holder:

- (a) if the Cash Settlement Amount after deducting all Exercise Expenses is greater than zero, the Issuer shall make payment of the Cash Settlement Amount to the relevant Holder; or
- (b) if the Cash Settlement Amount after deducting all Exercise Expenses is equal to or less than zero, the Issuer shall not be obliged to make any payment to the relevant Holder, and the relevant Structured Warrants shall lapse and cease to be valid and the Issuer's obligations in respect of the Structured Warrants shall terminate absolutely. The Holders shall not be required to pay or top up the Exercise Expenses in the event the Cash Settlement Amount is negative after deducting Exercise Expenses.

In such event, the Closing Price for the calculation of the Cash Settlement Amount (calculated in accordance with Condition 2) shall be one of the following:

- (i) the last quoted price of the Underlying Equity immediately before such events;
- (ii) the price determined in accordance with Condition 2.1.2(1)(a);
- (iii) in the case of a Take-over Offer or a Compulsory Acquisition, the announced price for such Take-over Offer or Compulsory Acquisition,
- (iv) such other price as determined by the Issuer in a commercially reasonable manner,

as the case may be, and the Issuer shall not be obliged to make any adjustment to the Exercise Price.

11.2 Subject to the aforesaid, the Issuer may but shall not be obliged to make any adjustment to the terms and conditions of the Structured Warrants and the rights attaching to the Structured Warrants as it shall reasonably consider appropriate to ensure, so far as it is reasonably able to do so, that the interests of the Holders generally are not materially prejudiced as a consequence of such events (without considering the individual circumstances of any Holder or the tax or other consequences that may result in any particular jurisdiction).

11A Takeover, Merger, Liquidation, Dissolution or Winding-Up of Issuer

11A.1 In the event of a take-over or a scheme of arrangement or any other form of reorganisation undertaken by the Issuer or any other events having similar effects on the rights of the Holders, the Issuer is entitled to deal with the Structured Warrants in such manner as it reasonably deems fit in the circumstances and with or without any adjustments to the rights attaching to the relevant Structured Warrants.

11A.2 In the event of a merger, amalgamation or reconstruction of the Issuer, the corporation, trust or other body into which the Issuer is merged, amalgamated or reconstructed shall assume all the liabilities and the obligations of the Issuer in respect of the Structured Warrants so that the rights of the Holders shall continue to exist and be enforceable to the same extent as provided by the Issuer under the Deed Poll.

11A.3 In the event of a liquidation, dissolution or winding-up of the Issuer or the appointment of a receiver or administrator or analogous person under any applicable law in respect of the whole or substantially

ANNEXURE I PRINCIPAL TERMS OF THE DEED POLL (cont'd)

the whole of the Issuer's undertaking, property or assets, the Structured Warrants remaining outstanding shall be deemed to be exercised on the Market Day immediately prior to the date of such liquidation, dissolution, winding-up or appointment as follows:

- (a) All unexercised Structured Warrants shall automatically be exercised without the Holders having to deliver a valid Exercise Form and without notice of automatic exercise being given by the Issuer to the Holders:
- (i) if the Cash Settlement Amount after deducting all the Exercise Expenses is greater than zero, the Issuer shall make payment of the Cash Settlement Amount to the relevant Holder; or
 - (ii) if the Cash Settlement Amount after deducting all the Exercise Expenses is equal to or less than zero, the Issuer shall not be obliged to make any payment to the relevant Holder, and the relevant Structured Warrants shall lapse and cease to be valid and the Issuer's obligations in respect of the Structured Warrants shall terminate absolutely. The Holders shall not be required to pay or top up the Exercise Expenses in the event the Cash Settlement Amount is negative after deducting Exercise Expenses.

The closing price of the Underlying Equity on the Market Day immediately before the above events shall form the Closing Price for the calculation of the Cash Settlement Amount for the Structured Warrants.

- (b) Notwithstanding the aforesaid, if there is a Market Disruption Event on the date immediately before the above events ("**Set Date**"), the closing price shall be based on the preceding Market Day after the Market Disruption Event. If the preceding day is also affected by the Market Disruption Event, then the closing price shall be determined by the Issuer on the Set Date as it reasonably deems fit and on the basis of the Issuer's good faith estimate the reference price and/or the exchange rate (if applicable) for that Set Date by determining the price of the Underlying Equity and/or the exchange rate (if applicable) based on the prevailing market conditions and other factors as the Issuer may consider relevant.

12 Replacement of Structured Warrant Certificate

- 12.1 If the Structured Warrant Certificate which has been deposited with Bursa Depository is mutilated, defaced, lost, worn out, stolen or destroyed it shall be replaced by the Issuer at the registered office of the Structured Warrants Registrar on such terms as to evidence and indemnity or otherwise as the Issuer may require. All payment of such costs as may be incurred in connection therewith shall be borne by the Issuer. Mutilated, defaced, lost, worn, stolen or destroyed Structured Warrant Certificates shall be deemed cancelled.

13 Register, Transfer and Transmission

- 13.1 Each Holder registered in the Record of Depositors shall be entitled to all rights, benefits, powers and privileges and be subject to all liabilities, duties and obligations in respect of, or arising from the Structured Warrants, and shall be deemed and treated as the absolute owner of the relevant Structured Warrants, in accordance with the Central Depositories Act and the Rules of Bursa Depository, whether or not the Issuer shall be in default in respect of the Structured Warrants or any of the covenants contained herein and notwithstanding any notice of ownership or writing thereon or notice of any previous loss or theft of any Structured Warrants. The provisions of the Central Depositories Act, the Rules of Bursa Depository and the Issuer's Articles for the time being relating to the registration, transfer and transmission of shares and the fees payable thereon shall with necessary modifications apply to the registration, transfer and transmission of the legal ownership of the Structured Warrants, subject always to the provisions of this Condition 13 and Condition 2.
- 13.2 The entries made under Record of Depositors shall be deemed to be the final record of all Depositors. No notice of any trust, express or implied, shall be entered upon the Record of Depositors otherwise than pursuant to an order of a court of competent jurisdiction or as required by law, and a Holder shall be deemed to be the beneficial owner of the Structured Warrants standing to the credit of his/its

ANNEXURE I **PRINCIPAL TERMS OF THE DEED POLL** *(cont'd)*

Securities Account, until such time as the Structured Warrants are duly transferred to another Holder and the name of the transferee is entered in the Record of Depositors.

14 Meetings of Holders

14.1 The procedure governing the convening and conduct of meetings of the Holders are set out in the Fourth Schedule to the Deed Poll.

15 Notices

15.1 Subject to Condition 15.2:

(a) all notices to the Holders pertaining to the convening of meetings shall be made by way notice published in at least one (1) English language national daily newspaper and announced through Bursa Securities; and

(b) all other notices shall either be announced through the Bursa Securities or published in at least one (1) English language national daily newspaper.

15.2 A notice is deemed to have been given and served on the date of announcement or publication as the case may be or, if announced or published more than once or on different dates, on the first date on which it is announced or published.

15.3 All notices effected in accordance with this Condition 15 shall be deemed to be effective in respect of all persons who become Holders after the date of the relevant notice.

15.4 For the avoidance of doubt, a notice shall not be required to be published or announced in respect of an event contemplated under Conditions 6, 8, 9, 10, 11 or 11A, as the case may be, if no adjustment to the rights of the Holders or amendment to the terms and conditions of the relevant Structured Warrants is made or to be made pursuant thereto.

16 Modification of rights

16.1 All or any of the rights for the time being attached to the Structured Warrants (other than the Exercise Price which a Holder is entitled to or the formulae for the adjustment of the Exercise Price or any other condition, which may be modified in accordance with the provisions set out elsewhere in these Conditions) may be altered or abrogated by the Issuer from time to time (whether or not the Issuer is being wound up), and the sanction of a Special Resolution passed at a meeting of the Holders held as aforesaid shall be necessary to effect such alteration or abrogation.

16.2 Notwithstanding Condition 16.1, the Issuer may without the consent of the Holders but in accordance with the terms of the Deed Poll, effect any modification to the Structured Warrants or the Deed Poll which, in the opinion of the Issuer, is:

(a) not materially prejudicial to the interests of the Holders; or

(b) of a formal, minor or technical nature; or

(c) necessary or expedient to correct a manifest error, or to comply with mandatory provisions of law or rules or regulations; or

(d) necessary or expedient to facilitate scripless trading in or exercise of the Structured Warrants or payment by way of electronic funds transfer as approved by the relevant government or statutory authorities in respect of the Structured Warrants or to amend the restrictions on transfer or exercise of the Structured Warrants to comply with the requirements of or the concessions granted by any relevant government or statutory authorities.

Any such modification shall be binding on all Holders and shall be notified by the Issuer to them as soon as practicable thereafter in accordance with Condition 15 but in any event not later than twenty (20) Market Days from the date of such modification.

16.3 Notwithstanding Condition 16.1, the Issuer may, at any time and from time to time for the purpose of an issue of new Structured Warrants or a new Series of Structured Warrants through the Base Prospectus and without the consent or sanction of the Holders supplement the Deed Poll with the

ANNEXURE I **PRINCIPAL TERMS OF THE DEED POLL** *(cont'd)*

terms and conditions of the new Structured Warrants or Series of Structured Warrants (as set out in the relevant Term Sheet), as the case may be. In the event such supplement to the Deed Poll shall affect the rights and interests of the Holders, the Issuer is to effect such supplement to the Deed Poll by notice to the Holders in accordance with Condition 15 and such supplement shall be binding on all Holders without any further action being required to be taken by the Issuer. For the avoidance of doubt, a Holder is deemed to have notice of all announcements (and their respective contents) made by the Issuer to Bursa Securities in respect of or affecting the Series of Structured Warrants held.

17 **Warrant Agency Agreement**

- 17.1 The Structured Warrants Registrar acts as an agent of the Issuer and shall not assume any obligation or duty to or any relationship of agency or trust for the Holders except only as described in Condition 17.2.
- 17.2 The Structured Warrants Registrar shall not be liable to any Holder in respect of any losses, liabilities, costs, claims, actions or demands which such Holder may suffer or incur or allege to have suffered or incurred as a result of or in connection with the exercise or non-exercise of any Structured Warrants Registrar's powers, discretions and/or duties. The Structured Warrants Registrar may:
- (a) in the exercise of its powers, discretions and/or duties, act on the advice or opinion of, or any certificate or information obtained in good faith from, any lawyer, valuer, accountant, banker, broker, securities company or other expert whether obtained by the Issuer, the relevant Structured Warrants Registrar or otherwise (which advice, opinion, certificate or information may be sent or obtained by letter, email, telex, telegram, cable or facsimile device) and the Structured Warrants Registrar shall not be liable for any loss occasioned by acting in good faith on any such advice, opinion, certificate or information unless there are reasonable grounds for concluding that the same may be forged or otherwise not authentic or containing some errors with respect to content, delivery or transmission;
 - (b) receive and retain without liability to account, such fee or other remuneration as may from time to time be agreed between the Issuer and the Structured Warrants Registrar; and
 - (c) enter into or be interested in any contract or financial or other transaction or arrangement with the Issuer or any person or body corporate associated with the Issuer in connection therewith receive and retain, without liability to account any profit, fee, remuneration or other benefit received thereby or in connection therewith.

The Structured Warrants Registrar does not act as the agent of any Holder and therefore owes no fiduciary duty to any Holder in arriving at its calculations and determinations.

18 **Exclusion of equities**

Subject to the Central Depositories Act, the Rules of Bursa Depository, the Deed Poll, or these Conditions, no person shall be recognised by the Issuer as holding any Structured Warrants upon any trust, and the Issuer shall not be bound by or compelled in any way to recognise any equitable, contingent, future or partial interest in any Warrant, or any interest in any fractional part of a Structured Warrant, or (except only as by these presents or by law otherwise provided) any other right in respect of any Structured Warrants, except an absolute right to the entirety thereof in the registered holder.

19 **Force Majeure**

- 19.1 If the Issuer determines that, for reasons beyond the Issuer's control, the performance of the Issuer's obligations under the Structured Warrants has become illegal or impractical in whole or in part for any reason, or the Issuer determines that, for reasons beyond the Issuer's control, it is no longer legal or practical for the Issuer to maintain the Issuer's hedging arrangements with respect to the Structured Warrants for any reason, the Issuer may in the Issuer's discretion and without obligation terminate the Structured Warrants early by giving notice to the Holders in accordance with Condition 15.

ANNEXURE I **PRINCIPAL TERMS OF THE DEED POLL** *(cont'd)*

20 **Governing law**

The Structured Warrants and the Deed Poll are governed by and shall be construed in accordance with the laws of Malaysia. The Issuer and the Holders irrevocably agree that with respect to any proceedings in Malaysia in connection with any matter or issue relating to the Deed Poll and these Conditions, they shall be bound by the decision, ruling or order of the Malaysian Court.

(the remainder of this page is intentionally left blank)

Privacy Notice (For Customers)**Personal Data Protection Act 2010 (“PDPA”)**

In line with PDPA, AmBank Group is committed to protect and safeguard customers’ Personal Data when entering into any commercial transaction with AmBank Group.

Throughout this Privacy Notice, the following are the definitions of the terms used:

- **AmBank Group** refers to AMMB Holdings Berhad and all its subsidiaries and associate companies including but not limited to AmBank (M) Berhad, AmBank Islamic Berhad, AmInvestment Bank Berhad, AmFunds Management Berhad, AmFutures Sdn Bhd, AmIslamic Funds Management Sdn Bhd, AmCards Services Berhad, AmGeneral Insurance Berhad, AmMetLife Insurance Berhad and AmMetLife Takaful Berhad.
- **Personal Data** refers to any information in respect of commercial transactions which is being processed and recorded that relates directly or indirectly to a Data Subject, who is identified or identifiable from that information. This includes any Sensitive Personal Data and expression of opinion about the Data Subject but does not include any information that is processed for the purpose of a credit reporting business carried on by a credit reporting agency under the Credit Reporting Agencies Act 2010. Examples of Personal Data include customer’s name, identity card or passport number, address, occupation, contact details, account details or financial information.
- **Sensitive Personal Data** refers to any Personal Data consisting of information as to the physical or mental health, condition, political opinions, religious beliefs or other beliefs of a similar nature.
- Unless expressly defined herein and where the context requires, all capitalized expressions shall have the same meaning ascribed to it in the PDPA.

Purpose of Collecting Personal Data

In rendering services to customers, AmBank Group may be required to process customers’ Personal Data for any of the following purposes:

- (a) Assessment of customers’ eligibility or suitability for AmBank Group’s products applied for and verification of identity or financial standing through credit reference checks;
- (b) Notification and/or update on new features or development of products and services;
- (c) Competitions, promotions, campaigns, offers and etc. from AmBank Group or third party business partners which customers have participated;
- (d) Account management and maintenance including regular updates, consolidation and improving accuracy of records;
- (e) Research for analytical purposes based on transactions/use of products and services for better understanding of current and future financial/investment needs;
- (f) Enforcement of AmBank Group’s rights to recover any debt owing, including transfer or assignment of rights, interests and obligations;
- (g) Any other purpose(s) that is required or permitted by any law, regulation, standard, guideline and/or by relevant regulatory authorities.

Sources of Personal Data

In providing Personal Data related to third parties to AmBank Group (such as next of kin or nominees), the provider of such Personal Data confirms that consent has been obtained or that he/she is entitled to provide the Personal Data of those parties.

- (a) Information provided in application forms when using AmBank Group’s products or services, when transacting accounts, when using online or electronic services, when taking part in customer surveys, competitions, promotions and during performance of financial reviews;
- (b) Verbal, written and/or electronic communications with AmBank Group or its authorised agents;

ANNEXURE II PDPA PRIVACY NOTICE (cont'd)*Customers*

- (c) Third parties connected to customers, such as their employer, joint account holder, security providers and guarantor(s), other partners in a partnership, or through AmBank Group's corporate customers or corporate security providers where the customer is a director, shareholder, officer or authorised signatory/person;
- (d) Images captured by closed circuit television (CCTV) cameras at AmBank Group's branches, office premises or third party premises (where self-service terminals are located), when visiting AmBank Group branches or office premises or self-service terminals at third party premises;
- (e) Credit reporting agencies and publicly available sources such as through searches at relevant government authorities or agencies; and/or
- (f) Any other sources which customers have given consent for the intended purposes.

Disclosure of Personal Data

AmBank Group may be required to disclose customers' Personal Data to the following third parties:

- (a) Its agents, service providers, vendors, financial institution(s) and /or professional advisers who assist us in processing, administering, outsourcing, fulfilling transactions or providing services to customers on its behalf, or to fulfill value added services that customers have requested;
- (b) Its external professional advisors and consultants who provide services to it, for the purposes of its business, operational, legal and regulatory requirements;
- (c) any person(s) authorised or appointed by customers to give instructions to AmBank Group on customers' behalf such as customers' agents, accountants, auditors, lawyers, financial advisers, brokers and intermediaries;
- (d) any guarantor(s), security provider(s) or any person(s) intending to settle any moneys outstanding under the facility(ies) granted by AmBank Group to customers;
- (e) any third party(ies) arising from the restructuring of facility(ies) granted to you, sale of debts, acquisition or sale of any company by AmBank Group provided that the recipient uses customers' data for the same purpose(s) as it was originally supplied to and/or used by AmBank Group;
- (f) merchants and electronic fund transfer facilitators related to any credit/debit card(s) issued to customers by AmBank Group;
- (g) any rating agency(ies), credit reporting agencies, insurer(s), insurance broker(s), re-insurers, loss adjusters, or direct/indirect provider(s) of credit protection and in the event of default of a facility granted to customers, to debt collection agencies; and/or
- (h) with other entities within AmBank Group for products and services that may be of interest to customers; and/or
- (i) any competent authority(ies) and/or regulator(s), for the performance of their functions.

Rights of Data Subject

Obligatory and voluntary Personal Data may differ for various products and services as indicated in the application forms. Customers may notify AmBank Group in writing to withdraw consent or to cease/begin processing Personal Data, giving AmBank Group a reasonable period of time to carry out such request.

However, in the event the customer chooses to withdraw consent during an existing contractual agreement with AmBank Group which may result in its inability to continue the relationship, AmBank Group reserves the right to continue processing customer's personal data in accordance with contractual obligations until all obligations are fulfilled.

Customers can access and/or make changes to their Personal Data by completing the Personal Data Request Form available at AmBank Group branches or website subject to relevant processing fees, where applicable and AmBank Group shall notify customers the reasons if such request cannot be acceded to. Customers may contact the following for enquiries:

AmBank Contact Centre

Customers

P.O. Box No. 12617
50784 Kuala Lumpur
1300 80 8888 (Domestic)
(603) 2178 8888 (Overseas) (24 hours)
customercare@ambankgroup.com

Security of Personal Data

AmBank Group places great importance in ensuring the security and confidentiality of its customers' Personal Data. As such, AmBank Group regularly reviews and implements up-to-date technical and organisational security measures when processing customers' Personal Data. Further information on security controls is available at our Website Security Statement at www.ambankgroup.com.

Retention of Personal Data

Customers' Personal Data will be retained in accordance with this Privacy Notice and/or the terms and conditions of agreement(s) with AmBank Group for the duration of the relationship or for such period as may be necessary to protect the interest of both AmBank Group and the customers. Such retention is also necessary as required by law or in accordance with relevant internal policies.

Revisions to Privacy Notice

This Privacy Notice may be revised from time to time and notice of such revision shall be posted on website and/or other means of communication deemed suitable by AmBank Group.

(Last updated: 7 November 2016)

[The rest of this page has been intentionally left blank]

Notis Privasi (Untuk Pelanggan)**Akta Perlindungan Data Peribadi 2010 (“APDP”)**

Selaras dengan APDP, Kumpulan AmBank komited untuk melindungi dan menjaga Data Peribadi pelanggan apabila mereka melakukan sebarang transaksi komersial dengan Kumpulan AmBank.

Berikut ialah definisi bagi terma-terma yang digunakan dalam keseluruhan Notis Privasi ini.

- **Kumpulan AmBank** merujuk kepada AMMB Holdings Berhad dan semua anak syarikat dan syarikat bersekutunya termasuk tetapi tidak terhad kepada AmBank (M) Berhad, AmBank Islamic Berhad, AmInvestment Bank Berhad, AmFunds Management Berhad, AmFutures Sdn Bhd, AmIslamic Funds Management Sdn Bhd, AmCards Services Berhad, AmGeneral Insurance Berhad, AmMetLife Insurance Berhad dan AmMetLife Takaful Berhad.
- **Data Peribadi** merujuk kepada sebarang maklumat berkaitan transaksi komersial yang sedang diproses dan direkodkan yang berkait secara langsung atau tidak langsung dengan satu Subjek Data, yang dikenal pasti atau dapat dikenal pasti daripada maklumat tersebut. Ini termasuk sebarang Data Peribadi Sensitif dan pernyataan pendapat mengenai Subjek Data tetapi tidak termasuk sebarang maklumat yang diproses bagi tujuan perniagaan pelaporan kredit yang dijalankan oleh agensi pelaporan kredit di bawah Akta Agensi Pelaporan Kredit 2010. Contoh Data Peribadi termasuk nama, kad pengenalan atau nombor pasport, alamat, pekerjaan, butiran hubungan, butiran akaun atau maklumat kewangan pelanggan.
- **Data Peribadi Sensitif** merujuk kepada sebarang Data Peribadi yang mengandungi maklumat berkaitan kesihatan fizikal atau mental, keadaan, pendapat politik, kepercayaan agama atau kepercayaan lain yang seumpamanya.
- Kecuali ditakrifkan dengan nyata di sini dan di mana konteks memerlukan, semua ungkapan yang berhuruf besar hendaklah mempunyai makna yang sama seperti yang ditentukan kepadanya dalam APDP.

Tujuan Mengumpul Data Peribadi

Dalam menyediakan perkhidmatan kepada pelanggannya, Kumpulan AmBank mungkin dikehendaki memproses Data Peribadi pelanggan untuk mana-mana tujuan yang berikut:

- (a) Penilaian ke atas kelayakan atau kesesuaian pelanggan untuk produk-produk Kumpulan AmBank yang dipohon dan pengesahan identiti atau kedudukan kewangan melalui semakan rujukan kredit;
- (b) Pemberitahuan dan/atau kemas kini tentang ciri-ciri baharu atau pembangunan produk dan perkhidmatan;
- (c) Pertandingan, promosi, kempen, tawaran dan sebagainya daripada Kumpulan AmBank atau rakan-rakan kongsi perniagaan pihak ketiga yang telah disertai oleh pelanggan;
- (d) Pengurusan dan penyenggaraan akaun termasuk pengemaskinian berkala, konsolidasi dan menambah baik ketepatan rekod;
- (e) Penyelidikan bagi tujuan-tujuan analisis berdasarkan transaksi/ penggunaan produk dan perkhidmatan untuk memahami dengan lebih baik tentang keperluan kewangan/ pelaburan semasa dan masa hadapan;
- (f) Penguatkuasaan hak-hak Kumpulan AmBank untuk mendapatkan semula sebarang hutang, termasuk pemindahan atau penyerahan hak, kepentingan dan obligasi;
- (g) Sebarang tujuan lain yang diperlukan atau dibenarkan oleh mana-mana undang-undang, peraturan, standard, garis panduan dan/atau oleh badan-badan penguatkuasa yang berkaitan.

Sumber-Sumber Data Peribadi

Apabila menyediakan Data Peribadi yang berkaitan dengan pihak ketiga kepada Kumpulan AmBank (seperti maklumat waris terdekat atau penama), penyedia Data Peribadi tersebut mengesahkan yang kebenaran telah diperolehi atau bahawa beliau berhak untuk memberikan Data Peribadi pihak-pihak tersebut.

ANNEXURE II PDPA PRIVACY NOTICE (cont'd)

- (a) Maklumat yang diberikan dalam borang permohonan apabila menggunakan produk atau perkhidmatan Kumpulan Ambank, apabila melakukan transaksi akaun, apabila menggunakan perkhidmatan dalam talian atau elektronik, apabila mengambil bahagian dalam kaji selidik pelanggan, pertandingan, promosi dan semasa semakan prestasi kewangan;
- (b) Komunikasi lisan, bertulis dan/atau elektronik dengan Kumpulan Ambank atau ejen-ejennya yang sah;
- (c) Pihak-pihak ketiga yang berkait dengan pelanggan seperti majikan mereka, pemegang akaun bersama, penyedia keselamatan dan penjamin, lain-lain rakan kongsi dalam sebuah perkongsian atau melalui pelanggan korporat atau penyedia keselamatan korporat Kumpulan Ambank yang mana pelanggan ialah pengarah, pemegang saham, pegawai atau penandatangani/orang yang dibenarkan;
- (d) Imej-imej yang diambil oleh kamera televisyen litar tertutup (CCTV) di cawangan, premis pejabat Kumpulan Ambank atau premis pihak ketiga (di mana terletak terminal layan-diri), apabila melawat cawangan atau premis pejabat Kumpulan Ambank atau terminal layan-diri di premis pihak ketiga;
- (e) Agensi-agensi pelaporan kredit dan sumber-sumber yang tersedia secara terbuka seperti carian melalui pihak berkuasa atau agensi kerajaan yang berkaitan; dan/atau
- (f) Mana-mana sumber yang lain yang mana pelanggan telah memberikan kebenarannya untuk tujuan-tujuan yang dimaksudkan tersebut.

Pendedahan Data Peribadi

Kumpulan Ambank mungkin akan dikehendaki untuk mendedahkan Data Peribadi pelanggan kepada pihak-pihak ketiga yang berikut:

- (a) Ejen, penyedia perkhidmatan, vendor, institusi kewangan dan/atau penasihat profesional yang membantu kami dalam memproses, mentadbir, menyumberluar, memenuhi transaksi atau menyediakan perkhidmatan kepada pelanggan bagi pihaknya atau untuk memenuhi perkhidmatan tambah nilai yang telah diminta oleh pelanggan;
- (b) Penasihat profesional dan perunding luar yang menyediakan perkhidmatan kepadanya, bagi tujuan keperluan perniagaannya, operasi, perundangan dan peraturan;
- (c) mana-mana orang yang diberi kuasa atau dilantik oleh pelanggan untuk memberi arahan kepada Kumpulan Ambank bagi pihak pelanggan seperti ejen, akauntan, juruaudit, peguam, penasihat kewangan, broker dan perantara pelanggan;
- (d) mana-mana penjamin, penyedia keselamatan atau mana-mana orang yang berhasrat untuk melangsaikan sebarang wang belum dijelas di bawah kemudahan yang diberikan oleh Kumpulan Ambank kepada pelanggan;
- (e) mana-mana pihak ketiga yang timbul daripada penstrukturan semula kemudahan yang diberikan kepada anda, penjualan hutang, pemerolehan atau jualan mana-mana syarikat oleh Kumpulan Ambank dengan syarat penerima menggunakan data pelanggan untuk tujuan yang sama seperti mana ia diberikan pada asalnya kepada dan/atau digunakan oleh Kumpulan Ambank;
- (f) saudagar dan fasilitator pemindahan dana elektronik berkaitan dengan mana-mana kad kredit/debit yang dikeluarkan kepada pelanggan oleh Kumpulan Ambank;
- (g) mana-mana agensi penarafan, agensi pelaporan kredit, penginsurans, broker insurans, penginsurans semula, pelaras kerugian atau penyedia perlindungan kredit secara langsung /tidak langsung dan sekiranya berlaku keingkaran terhadap kemudahan yang diberikan kepada pelanggan, kepada agensi kutipan hutang; and/atau
- (h) dengan lain-lain entiti dalam Kumpulan Ambank untuk produk dan perkhidmatan yang mungkin menarik minat pelanggan; dan/atau
- (i) mana-mana pihak berkuasa dan/atau penguatkuasa kompeten, bagi pelaksanaan fungsi-fungsi mereka.

Hak-Hak Subjek Data

Data Peribadi wajib dan sukarela mungkin berbeza untuk pelbagai produk dan perkhidmatan seperti yang dinyatakan dalam boring permohonan. Pelanggan boleh memaklumkan Kumpulan Ambank secara bertulis untuk menarik balik kebenaran atau untuk menamatkan/ memulakan pemprosesan Data Peribadi. Ini akan memberikan Kumpulan Ambank tempoh masa yang munasabah untuk melaksanakan permintaan yang sedemikian.

Walau bagaimanapun, sekiranya pelanggan memilih untuk menarik balik kebenaran dalam tempoh perjanjian kontrak sedia ada dengan Kumpulan Ambank yang mungkin menyebabkannya tidak berupaya untuk meneruskan perhubungan tersebut, Kumpulan Ambank berhak untuk meneruskan kerja memproses data peribadi pelanggan selaras dengan obligasi kontrak sehingga semua obligasi dipenuhi.

Pelanggan boleh mengakses dan/atau membuat perubahan kepada Data Peribadi mereka dengan melengkapkan Borang Permohonan Data Peribadi yang boleh didapati di cawangan atau laman sesawang Kumpulan Ambank, tertakluk kepada fi pemprosesan yang berkaitan di mana terpakai dan Kumpulan Ambank akan memaklumkan kepada pelanggan sebab-sebab jika permohonan yang sedemikian tidak dapat dipenuhi. Pelanggan boleh menghubungi yang berikut untuk sebarang pertanyaan:

Pusat Hubungan AmBank
Peti Surat No. 12617
50784 Kuala Lumpur
1300 80 8888 (Domestik)
(603) 2178 8888 (Luar Negara) (24 jam)
customercare@ambankgroup.com

Keselamatan Data Peribadi

Kumpulan Ambank amat menekankan soal kepentingan memastikan keselamatan dan kerahsiaan Data Peribadi pelanggannya. Oleh itu, Kumpulan Ambank sentiasa menyemak dan melaksanakan langkah-langkah keselamatan teknikal dan organisasi yang terkini apabila memproses Data Peribadi pelanggan. Maklumat lanjut tentang kawalan keselamatan boleh didapati di Penyata Keselamatan Laman Web kami di www.ambankgroup.com.

Pengekalan Data Peribadi

Data Peribadi pelanggan akan dikekalkan selaras dengan Notis Privasi ini dan/atau terma dan syarat perjanjian dengan Kumpulan Ambank untuk sepanjang tempoh perhubungan tersebut atau untuk tempoh yang perlu bagi melindungi kepentingan Kumpulan Ambank dan pelanggan. Pengekalan sedemikian juga penting seperti yang dikehendaki oleh undang-undang atau selaras dengan polisi dalaman yang berkaitan.

Semakan kepada Notis Peribadi

Notis Peribadi ini mungkin akan disemak dari semasa ke semasa dan notis mengenai semakan yang sedemikian akan dipaparkan di laman sesawang dan/atau melalui lain-lain kaedah komunikasi yang dianggap sesuai oleh Kumpulan Ambank.

Kemas kini terakhir: 7 November 2016